

HITACHI

Inspire the Next

SPLIT TYPE AIR CONDITIONER

INDOOR UNIT/OUTDOOR UNIT

MODEL

RPC-30MH1 / RAC-30MH1

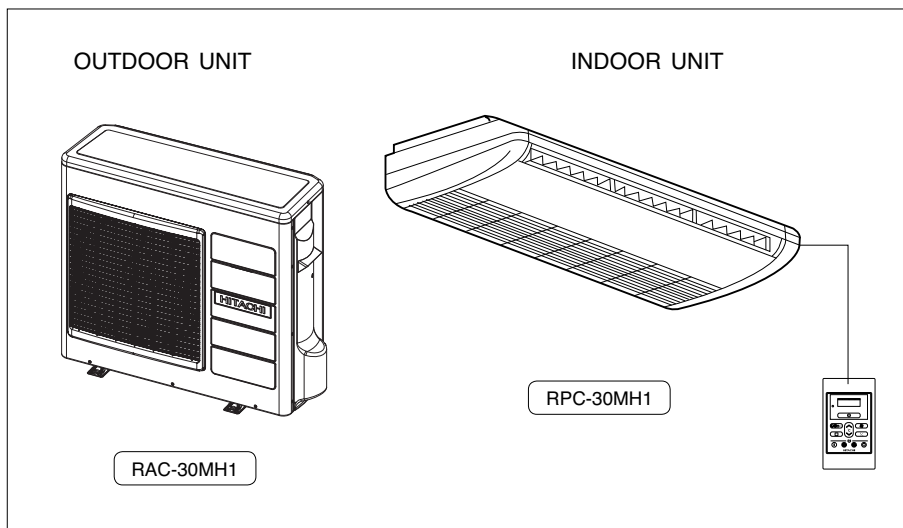



Instruction manual

To obtain the best performance, please read this instruction manual completely.







SAFETY PRECAUTION

- Please read the “Safety Precaution” carefully before operating the unit to ensure correct usage of the unit.
- Pay special attention to signs of “**Warning**” and “**Caution**”. The “Warning” section contains matters which, if not observed strictly, may cause death or serious injury. The “Caution” section contains matters which may result in serious consequences if not observed properly. Please observe all instructions strictly to ensure safety.
- The sign indicate the following meanings.



| | |
|--|---|
|  Make sure to connect earth line. |  The sign in the figure indicates prohibition. |
|  Indicates the instructions that must be followed. | |

- Please keep this manual after reading.







PRECAUTIONS DURING INSTALLATION

| | | |
|---|--|---|
|  WARNING | <ul style="list-style-type: none"> • Do not reconstruct the unit. Water leakage, fault, short circuit or fire may occur if you reconstruct the unit by yourself. |  |
| | <ul style="list-style-type: none"> • Please ask your sales agent or qualified technician for the installation of your unit. Water leakage, short circuit or fire may occur if you install the unit by yourself. • Please use earth line. Do not place the earth line near water or gas pipes, lightning-conductor, or the earth line of telephone. Improper installation of earth line may cause electric shock. |  |
|  CAUTION | <ul style="list-style-type: none"> • A circuit breaker should be installed depending on the mounting site of the unit. Without a circuit breaker, the danger of electric shock exists. • Do not install near location where there is flammable gas. The outdoor unit may catch fire if flammable gas leaks around it. • Please ensure smooth flow of water when installing the drain hose. |  |

PRECAUTIONS DURING SHIFTING OR MAINTENANCE

| | | |
|--|--|---|
|  WARNING | <ul style="list-style-type: none"> • Should abnormal situation arises (like burning smell), please stop operating the unit and turn off the circuit breaker. Contact your agent. Fault, short circuit or fire may occur if you continue to operate the unit under abnormal situation. |   |
| | <ul style="list-style-type: none"> • Please contact your agent for maintenance. Improper self maintenance may cause electric shock and fire. | |
| | <ul style="list-style-type: none"> • Please contact your agent if you need to remove and reinstall the unit. Electric shock or fire may occur if you remove and reinstall the unit yourself improperly. | |
| | <ul style="list-style-type: none"> • If the supply cord is damaged, it must be replaced by the special cord obtainable at authorized service/parts centers. | |

PRECAUTIONS DURING OPERATION

| | | |
|--|---|---|
|  WARNING | <ul style="list-style-type: none"> • Avoid an extended period of direct air flow for your health. |  |
| | <ul style="list-style-type: none"> • Do not insert a finger, a rod or other objects into the air outlet or inlet. As the fan is rotating at a high speed, it will cause injury. Before cleaning, be sure to stop the operation and turn the breaker OFF. |  |
| | <ul style="list-style-type: none"> • Do not use any conductor as fuse wire, this could cause fatal accident. |  |
| | <ul style="list-style-type: none"> • During thunder storm, disconnect and turn off the circuit breaker. |   |

PRECAUTIONS DURING OPERATION

- The product shall be operated under the manufacturer specification and not for any other intended use.



- Do not attempt to operate the unit with wet hands, this could cause fatal accident.

- When operating the unit with burning equipments, regularly ventilate the room to avoid oxygen insufficiency.



- Do not direct the cool air coming out from the air-conditioner panel to face household heating apparatus as this may affect the working of apparatus such as the electric kettle, oven etc.

- Please ensure that outdoor mounting frame is always stable, firm and without defect. If not, the outdoor unit may collapse and cause danger.



C
A
U
T
I
O
N



- Do not splash or direct water to the body of the unit when cleaning it as this may cause short circuit.

- Do not use any aerosol or hair sprays near the indoor unit. This chemical can adhere on heat exchanger fin and blocked the evaporation water flow to drain pan. The water will drop on tangential fan and cause water splashing out from indoor unit.



- Please switch off the unit and turn off the circuit breaker during cleaning, the high-speed fan inside the unit may cause danger.

- Turn off the circuit breaker if the unit is not to be operated for a long period.



- Do not climb on the outdoor unit or put objects on it.

- When operating the unit with the door and windows opened, (the room humidity is always above 80%) and with the air deflector facing down or moving automatically for a long period of time, water will condense on the air deflector and drips down occasionally. This will wet your furniture. Therefore, do not operate under such condition for a long time.

- If the amount of heat in the room is above the cooling or heating capability of the unit (for example: more people entering the room, using heating equipments and etc.), the preset room temperature cannot be achieved.

- This appliance is not intended for use by young children unless they have been adequately supervised by a responsible person to ensure that they can use the appliance safely.
- Young children should be supervised to ensure that they do not play with the appliance.

NAMES AND FUNCTIONS OF EACH PART

INDOOR UNIT

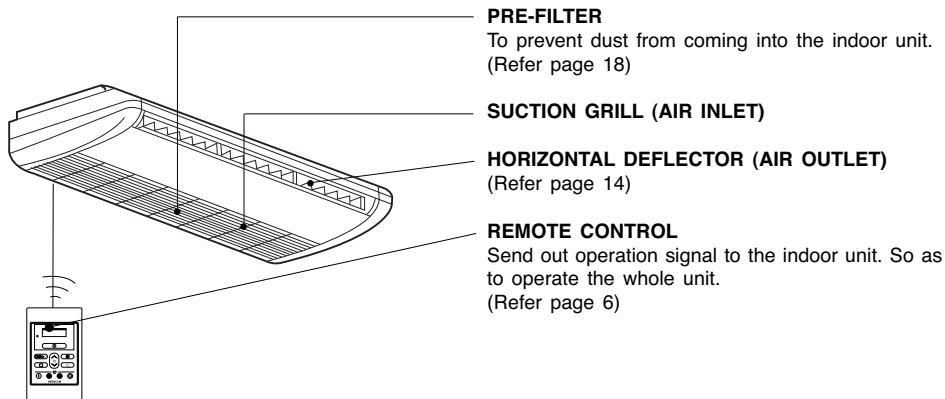

OUTDOOR UNIT

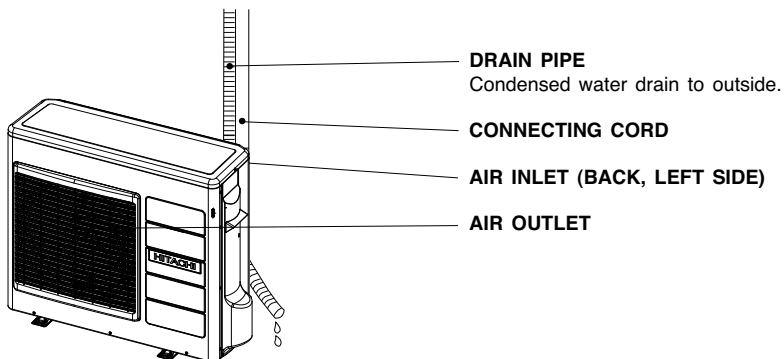

MODEL NAME AND DIMENSIONS

| MODEL | WIDTH (mm) | HEIGHT (mm) | DEPTH (mm) |
|-----------|------------|-------------|------------|
| RPC-30MH1 | 1320 | 210 | 670 |
| RAC-30MH1 | 850 | 800 | 298 |

OPERATION INDICATOR

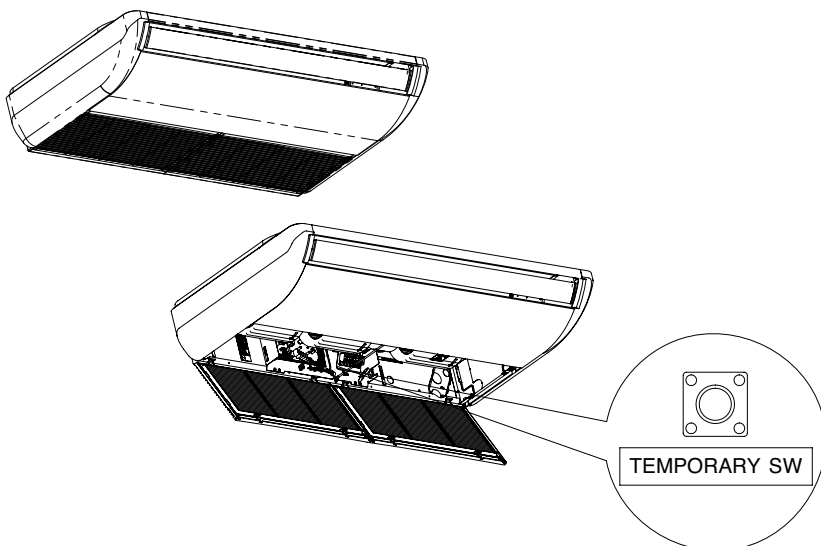

TEMPORARY SWITCH

Use this switch to start and stop when the remote controller does not work.

Normal operation:

- By pressing the temporary switch, the operation is done in previously set operation mode.
- When the operation is done using the temporary switch after the power source is turned off and turn on again, the operation is done in automatic mode.

Force cooling operation: (For servicing purpose only)

- By pressing and hold the temporary switch for more than 5 second, the unit will enter "Force Cooling Operation".
- Press again the temporary switch to cancel the force cooling operation.
- Do not operate in this mode for more than 5 minutes.

* To be conduct by authorised personel only.

NAMES AND FUNCTIONS OF REMOTE CONTROL UNIT

■ This controls the operation function and timer setting of the room air conditioner.

START/STOP Button

Press this button to start operation.
Press it again to stop operation.

OPERATION LAMP

FUNCTION Button

Use this button to select the operating mode. Every time you press it, the mode will change from (AUTO) to (HEAT) to (DEHUMIDIFY) and to (COOL) cyclically.

SLEEP Button

Use this button to set the sleep timer. (Page 11)

Reserve Button

Timer setting reservation.

OFF TIMER Button

Select the turn OFF time.

ON TIMER Button

Select the turn ON time.

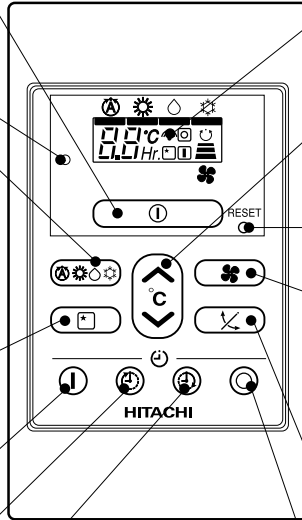

Transmission Sign

The transmission sign blinks when a signal has been sent.

TEMPERATURE Button

Room temperature setting.
Value will change quicker when keep pressing.

RESET Button

FAN SPEED Button

This determines the fan speed.
Every time you press this button, the intensity of circulation will change from (AUTO) to (HI) to (MED) to (LOW) (This button allows selecting the optimal or preferred fan speed for each operation mode).

AUTO SWING Button

Controls the angle of the horizontal air deflector.

CANCEL Button

Cancel timer reservation.

Precautions for Use

- Do not put the remote controller in the following places.
 - Under direct sunlight.
 - In the vicinity of a heater.
- Handle the remote controller carefully. Do not drop it on the floor, and protect it from water.
- Once the outdoor unit stops, it will not restart for about 3 minutes (unless you turn the power switch off and on or unplug the power cord and plug it in again).
This is to protect the device and does not indicate a failure.
- If you press the FUNCTION selector button during operation, the device may stop for about 3 minutes for protection.

VARIOUS FUNCTIONS

Auto Restart Control

- If there is a power failure, operation will be automatically restarted when the power is resumed with previous operation mode.
(As the operation is not stopped by remote controller.)
- If you intend not to continue the operation when the power is resumed, switch off the power supply.
When you switch on the circuit breaker, the operation will be automatically restarted with previous operation mode.
Note: 1. If you do not require Auto Restart Control, please consult your sales agent or OFF by remote control.
2. Auto Restart Control is not available when Timer or Sleep Timer mode is set.

AUTOMATIC OPERATION

The device will automatically determine the mode of operation, HEAT, COOL or DEHUMIDIFY depending on the current room temperature. The selected mode of operation will change when the room temperature varies.

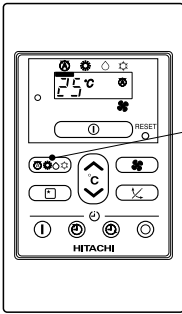

1

Press the FUNCTION selector so that the display indicates the **A** (AUTO) mode of operation.

- When AUTO has been selected, the device will automatically determine the mode of operation, HEAT, COOL or DEHUMIDIFY depending on the current room temperature.
- If the mode automatically selected by the unit is not satisfactory, manually change the mode setting (heat, dehumidify or cool).

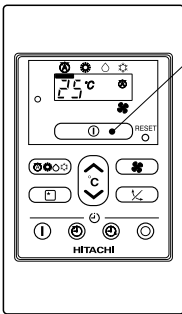

START STOP

Press the **1** (START/STOP) button.
Operation starts with operation lamp lights.
Press the button again to stop operation.

- As the settings are stored in memory in the remote controller, you only have to press the **1** (START/STOP) button next time.

You can raise or lower the temperature setting as necessary.



Press the temperature button and the temperature setting will change by 1°C each time.

- The preset temperature and the actual room temperature may vary somewhat depending on conditions.
- The display will indicate the temperature setting.

FAN SPEED (AUTO) When the AUTO fan speed mode is set in the cooling/heating operation:

| | |
|---------------------------|--|
| For the heating operation | <ul style="list-style-type: none"> ● The fan speed will automatically change according to the temperature of discharged air. ● When the difference of room temperature and setting temperature is large, fan starts to run at HI speed. ● When the room temperature reaches setting temperature, fan speed changes to LOW automatically. |
| For the cooling operation | <ul style="list-style-type: none"> ● When the difference of room temperature and setting temperature is large, fan starts to run at HI speed. ● After room temperature reaches the preset temperature, the cooling operation, which changes the fan speed and room temperature to obtain optimum conditions for natural healthful cooling will be performed. |

HEATING OPERATION

- Use the device for heating when the outdoor temperature is under 15°C.
When it is too warm (over 15°C), the heating function may not work in order to protect the device.
- In order to keep reliability of the device, please use this device above -10°C of the outdoor temperature.

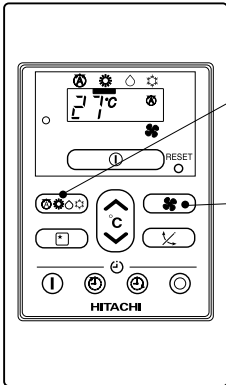

1

Press the FUNCTION selector so that the display indicates  (HEAT).

Set the desired FAN SPEED with the  (FAN SPEED) button (the display indicates the setting).

 (AUTO): The fan speed is HI at first and varies to MED or LOW automatically when the preset temperature has been reached.

 (HI) : Economical as the room will become warm quickly.
But you may feel a chill at the beginning.

 (MED) : Fan speed slow.

 (LOW) : Fan speed slower.

2

Set the desired room temperature with the TEMPERATURE buttons (the display indicates the setting).

3

The temperature setting and the actual room temperature may vary somewhat depending on conditions.

**START
STOP**

Press the  (START/STOP) button. Heating operation starts with operation lamp lights. Press the button again to stop operation.

- As the settings are stored in memory in the remote controller, you only have to press the  (START/STOP) button next time.

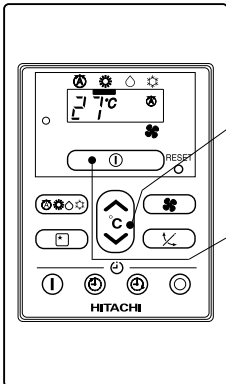

DEHUMIDIFYING OPERATION

Use the device for dehumidifying when the room temperature is over 16°C.
When it is under 15°C, the dehumidifying function will not work.

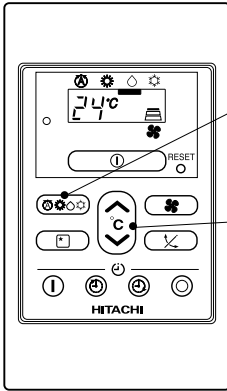
1

Press the FUNCTION selector so that the display indicates ◯ (DEHUMIDIFY).
The FAN SPEED is set at LOW automatically.
The FAN SPEED button does not work.

2

Set the desired room temperature with the TEMPERATURE button (the display indicates the setting).



The range of 20-26°C is recommended as the room temperature for dehumidifying.

**START
STOP**

Press the Ⓛ (START/STOP) button. Dehumidifying operation starts with operation lamp lights. Press the button again to stop operation.

- As the settings are stored in memory in the remote controller, you only have to press the Ⓛ (START/STOP) button next time.

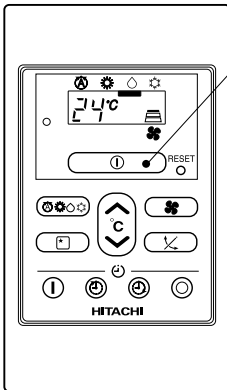

■ Dehumidifying Function

When the room temperature is higher than the temperature setting: The device will dehumidify the room, reducing the room temperature to the preset level.

When the room temperature is lower than the temperature setting: Dehumidifying will be performed at the temperature setting slightly lower than the current room temperature, regardless of the temperature setting. The function will stop (the indoor unit will stop emitting air) as soon as the room temperature becomes lower than the setting temperature.

COOLING OPERATION

Use the device for cooling when the outdoor temperature is $-10\sim 43^{\circ}\text{C}$.

If indoor humidity is very high (80%), some dew may form on the air outlet grille of the indoor unit.

Note: When outdoor ambient temperature is low and the device is required to run cooling operation, the outdoor fan may reduce its speed based on micon judgement. This is to prevent dew formation at indoor unit air blow area or ice formation on the indoor heat exchanger.

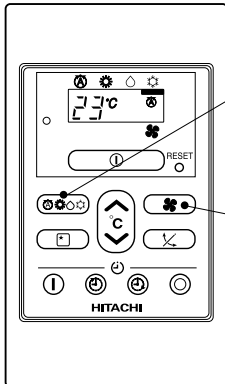

1

Press the FUNCTION selector so that the display indicates ☀ (COOL).

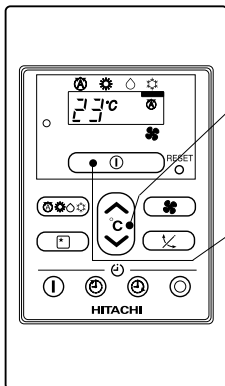

2

Set the desired FAN SPEED with the 🌀 (FAN SPEED) button (the display indicates the setting).

Ⓐ (AUTO): The FAN SPEED is HI at first and varies to MED or LOW automatically when the preset temperature has been reached.

☰ (HI) : Economical as the room will become cool quickly.

☷ (MED) : Fan speed slow.

☶ (LOW) : Fan speed slower.

3

Set the desired room temperature with the TEMPERATURE button (the display indicates the setting).

The temperature setting and the actual room temperature may vary somehow depending on conditions.

START
STOP

Press the ⏻ (START/STOP) button. Cooling operation starts with operation lamp lights. Press the button again to stop operation. The cooling function does not start if the temperature setting is higher than the current room temperature (even though the Ⓛ (OPERATION) lamp lights). The cooling function will start as soon as you set the temperature below the current room temperature.

- As the settings are stored in memory in the remote controller, you only have to press the ⏻ (START/STOP) button next time.

TIMER RESERVATION

■ ON Timer and OFF Timer are available.

OFF Timer Reservation

1 Ⓞ OFF TIME setting

- Select the OFF TIME by pressing the Ⓞ (OFF) Button.
- Setting time will change according to the below sequence when you press the button.

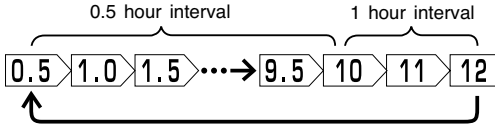

- The value change quicker if you keep pressing the button.

2 Press the ⓑ (Reserve) button

- OFF TIMER reserved when press the ⓑ (Reserve) button.
- The ⓑ (OFF) mark starts lighting instead of blinking.

ON Timer Reservation

1 Ⓞ ON TIME setting

- Select the ON TIMER by pressing the Ⓞ (ON) Button.
- At the beginning of setting, time 6 hours was set.
- Setting time will change according to the below sequence.

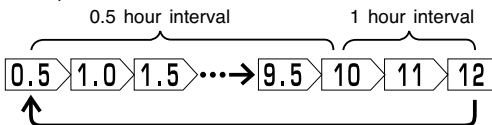

- The value change quicker if you keep pressing the button.

2 Press the ⓑ (Reserve) button

- ON TIMER reserved when press the ⓑ (Reserve) button.
- The ⓑ (ON) mark starts lighting instead of blinking.

CANCELLATION of Timer Reservation

1 Press the Ⓞ (Cancel) button

- As the time settings are stored in remote controller memory, you only have to press the ⓑ (Reserve) button in order to use the same setting next time.

■ Operation stop at setting time

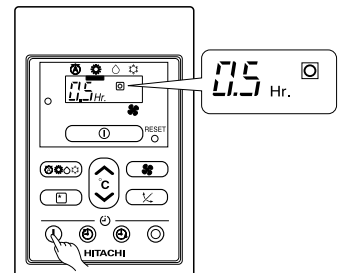
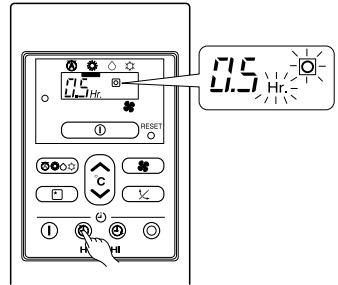

■ Operation will start for setting temperature at setting time (The starting time may different depend on the room temperature and set temperature).

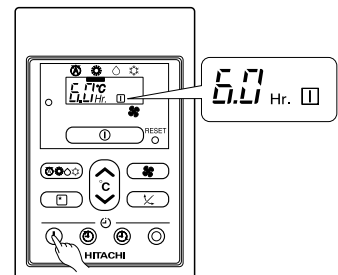
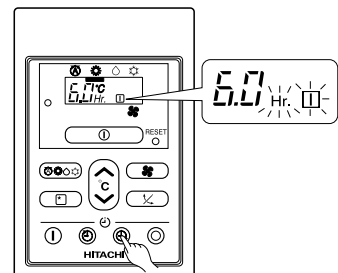

HOW TO SET THE SLEEP TIMER

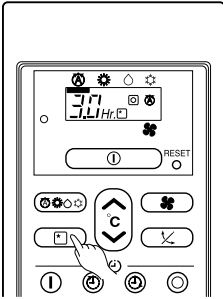



Example: Setting 3 hours sleep time.

| Mode | Indication |
|-------------|---|
| Sleep timer | → 1 hour → 2 hours → 3 hours → 7 hours → Sleep timer off ← |

Sleep Timer: The device will continue working for the designated number of hours and then turn off.
Press the SLEEP button, to set the sleep timer.
The timer information will be displayed on the remote controller.

How to Cancel Reservation

Press the  (CANCEL) button. The  (SLEEP TIMER) sign goes out from display.

Explanation of the sleep timer

The device will control the FAN SPEED and room temperature automatically so as to be quiet and good for people's health.

NOTE



- If you set the sleep timer after the off or on-timer has been set, the sleep timer becomes effective instead of the off or on-timer set earlier.
- You can not set other timer during sleep timer operation.
- After sleep timer time is up and when press sleep button again, the sleep timer will be set as last setting.
- Sleep timer is effective only once.

ADJUSTING THE AIR DEFLECTOR

1 Adjustment of the conditioned air in the upward and downward directions.

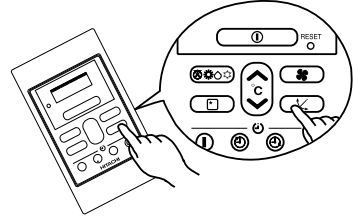
According to “Dehumidifying” or “Cooling” operation, the horizontal air deflector is automatically set to the proper angle suitable for each operation. The deflector can be swung up and down and also set to the desired angle using the “ (AUTO SWING)” button. (If the angle of the deflector is changed, it will not return to the auto-set position after operations start unless the operation mode is switched.)



- If the “ (AUTO SWING)” button is pressed once, the horizontal air deflector swings up and down. If the button is pressed again, the deflector stops in its current position. Several seconds (about 6 seconds) may be required before the deflector starts to move when press again.
- Use the horizontal air deflector within the adjusting range shown on the right.
- When the “ (AUTO SWING)” button is pressed while the operation is stopped, the horizontal air deflector moves and stops at the position where the air outlet closes.
- When the auto swing operation is performed, if the horizontal air deflector is moved manually, the swinging range may drift. However, it will return to the original operation range after a short time.

▲ CAUTION

When operating the unit in cooling operation with the air deflector facing down and moving automatically for a long period of time, water will be condensed on the air deflector and drips down occasionally. This will wet your furniture.

CIRCUIT BREAKER

When you do not use the room air conditioner, set the circuit breaker to "OFF".

HOW TO USE THE AIR CONDITIONER EFFECTIVELY

1. An average room temperature setting is probably the best for you as well as being economical.

- Excessive cooling or heating is not recommended for health reasons. High electricity bills may also result.
- Close the curtains or blinds to prevent heat from flowing into or escaping the room as well as to make more effective use of electricity.



2. At intervals, the doors and windows should be opened to let fresh air in.



CAUTION

Make sure the room is ventilated when operating the air conditioner at the same time as other heating appliances.



3. Using the timer is recommended before going to sleep or going out.



4. The following must never be used for cleaning the indoor and outdoor units.

- Benzene, thinner and scrub can damage plastic surfaces or coating.
- Hot water above 40°C can shrink the filter and deform plastic parts.



5. Do not block the air intake and air outlet.

- Do not block the air outlets and intakes of the indoor and outdoor units with curtains or other obstacles which could degrade air conditioner performance and cause unit failure.

THE IDEAL WAYS OF OPERATION

Suitable Room Temperature



⚠ Warning
Freezing temperature is bad for health and a waste of electric power.

Install curtain or blinds

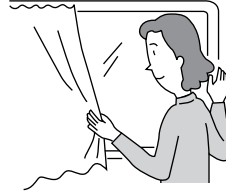

It is possible to reduce heat entering the room through windows.

Ventilation

⚠ Caution
Do not close the room for a long period of time. Occasionally open the door and windows to allow the entrance of fresh air.



Effective Usage Of Timer

At night, please use the "OFF or ON timer operation mode", together with your wake up time in the morning. This will enable you to enjoy a comfortable room temperature. Please use the timer effectively.

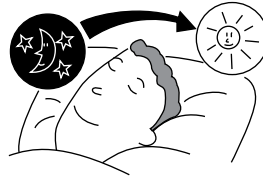

Do Not Forget To Clean The Air Filter

Dusty air filter will reduce the air volume and the cooling efficiency. To prevent from wasting electric energy, please clean the filter every 2 weeks.

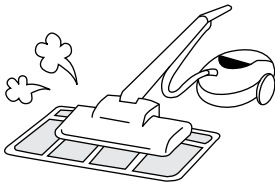

Please Adjust Suitable Temperature For Baby And Children

Please pay attention to the room temperature and air flow direction when operating the unit for baby, children and old folks who have difficulty in movement.



FOR USER'S INFORMATION

The Air Conditioner And The Heat Source In The Room

⚠ Caution

If the amount of heat in the room is above the cooling capability of the air conditioner (for example: more people entering the room, using heating equipments and etc.), the preset room temperature cannot be achieved.

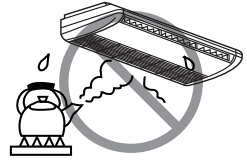

Not Operating For A Long Time

When the indoor unit is not to be used for a long period of time, please switch off the power from the mains. If the power from mains remains "ON", the indoor unit still consumes about 8W in the operation control circuit even if it is in "OFF" mode.

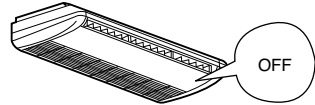

When Lightning Occurs

⚠ Warning

To protect the whole unit during lightning, please stop operating the unit and remove the plug from the socket.

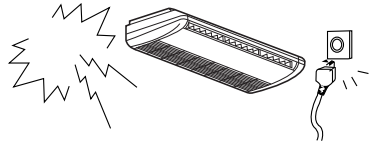

Interference From Electrical Products

⚠ Caution

To avoid noise interference, please place the indoor unit and its remote controller at least 1m away from electrical products.

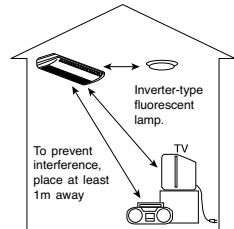

Product Operating Life

This term is valid only for the products, being purchased on the territory of Russian Federation.

In accordance with the article 5.2 of the Law "On Protection of Consumers" in operational conditions in Russian Federation the operating life of a domestic air conditioner is determined as 7 years from the date of manufacture. Considering the high quality, reliability and high level of operating safety of "Hitachi" products, the actual operating life may considerably exceed the official one.

This operating life is related to those parts of the product that are needed for its proper functioning under the following conditions:

- The item is properly assembled by a certified company and is used according to the service and operation manual.
- The repair and annual technical service are carried out by the company which installed this product

MAINTENANCE

⚠ CAUTION

Cleaning and maintenance must be carried out by qualified service personnel.
Before the cleaning, stop operation and disconnect the power supply.

1. CLEANING OF PRE-FILTER

1

Taking Out the Pre-Filter

- Take out the pre-filter according to the following steps.
 - **Step 1**
Open the air inlet grille after pushing the two knobs as shown by the arrow mark.
 - **Step 2**
Take out the pre-filter from the air inlet grille by supporting the air grille and lifting the pre-filter after detaching the pre-filter from two hinges.

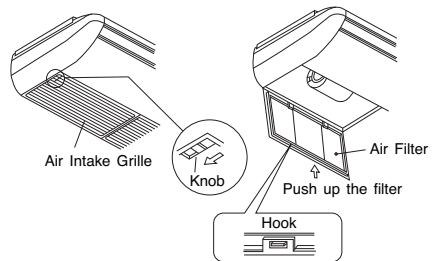

2

Clean the Pre-Filter

- Clean the pre-filter according to the following steps.
 - **Step 1**
Use a vacuum cleaner or let water flow onto the pre-filter for removing the dirt from the pre-filter.
 - **Step 2**
Dry the pre-filter in the shade after shaking off moisture.

Note:

- This model has an air purifying filter. The cooling capacity is slightly weakened and the cooling speed becomes slower when the air purifying filter is used. So, set the fan speed to "HIGH" when using it in this condition.

⚠ CAUTION

- Do not wash with hot water at more than 40°C. The pre-filter may shrink.
- When washing it, shake off moisture completely and dry it in the shade; do not expose it directly to the sun. The pre-filter may shrink.
- Do not operate the air conditioner with the pre-filter removed. Dust may enter the air conditioner and cause trouble.

2. CLEANING OF AIR PANEL

- Wipe it with a soft dry cloth.
- When it is excessively dirty, wipe with soft cloth soaked in lukewarm water or neutral detergent. Then wipe thoroughly with a soft dry cloth.

⚠ CAUTION

- Do not splash or direct water to the body of the unit when cleaning it as this may cause short circuit.
- Never use hot water (above 40°C), benzine, gasoline, acid, thinner or a brush, because they will damage the plastic surface and the coating.



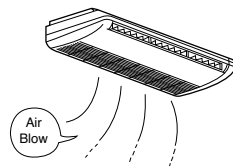

3. MAINTENANCE AT BEGINNING OF LONG OFF PERIOD

- Run the unit by setting the operation mode to  (COOL), the temperature to 32°C and the fan speed to HI for about half a day on a fine day, and dry the whole of the unit.
- Switch off the power plug.

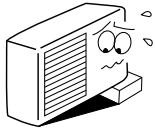

REGULAR INSPECTION

PLEASE CHECK THE FOLLOWING POINTS EITHER EVERY HALF YEARLY OR YEARLY. CONTACT YOUR SALES AGENT SHOULD YOU NEED ANY HELP.

| | | |
|---|---|--|
| 1 |  | <p>Is the earth line disconnected or broken?</p> <p>⚠ WARNING Coming off or breakage of grounding wire may cause malfunction or electrical shock.</p> |
| 2 |  | <p>Is the mounting frame seriously affected by rust and is the outdoor unit tilted or unstable?</p> <p>⚠ WARNING Outdoor unit may fall or drop if there is extreme rust on mounting frame or outdoor unit is unstably installed. This may cause injury.</p> |
| 3 |  | <p>Is the plug of power line firmly plugged into the socket? (Please ensure no loose contact between them).</p> |

AFTER SALE SERVICE AND WARRANTY

WHEN ASKING FOR SERVICE, CHECK THE FOLLOWING POINTS

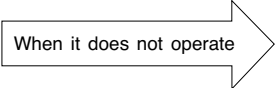
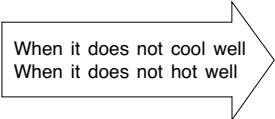
| CONDITION | CHECK THE FOLLOWING POINTS |
|--|--|
|  <p>When it does not operate</p> | <ul style="list-style-type: none">● Is the fuse all right?● Is the voltage extremely high or low?● Is the circuit breaker "ON"? |
|  <p>When it does not cool well When it does not hot well</p> | <ul style="list-style-type: none">● Was the air filter cleaned?● Does sunlight fall directly on the outdoor unit?● Is the air flow of the outdoor unit obstructed?● Are the doors or windows opened, or is there any source of heat in the room?● Is the set temperature suitable? |



Notes

- In quiet or stop operation, the following phenomena may occasionally occur, but they are not abnormal for the operation.
 - (1) Slight flowing noise of refrigerant in the refrigerating cycle.
 - (2) Slight rubbing noise from the fan casing which is cooled and then gradually warmed as operation stops.
- The odor will possibly be emitted from the room air conditioner because the various odor, emitted by smoke, foodstuffs, cosmetics and so on, sticks to it. So the air filter and the evaporator regularly must be cleaned to reduce the odor.

- Please contact your sales agent immediately if the air conditioner still fails to operate normally after the above inspections. Inform your agent of the model of your unit, production number, date of installation. Please also inform him regarding the fault.
- Power supply shall be connected at the rated voltage, otherwise the unit will be broken or could not reach the specified capacity.

