

1. Pipe Cutting and Flaring

- Use a pipe cutter to cut the pipe and remove burr.

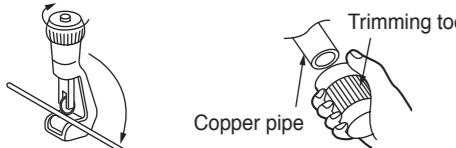

CAUTION

- Remove burr. If burr is not removed, it may cause leakage.
- Point the side to be trimmed downwards during trimming to prevent copper chips from entering the pipe.
- Before flaring, please put on the flare nut.

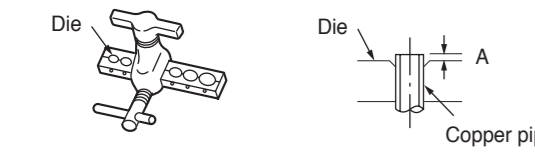

※ Please use exclusive tool for refrigerant R410.

Outer Diameter (ø)	A (mm) Rigid Flaring Tool	
	For R410A tool	For R22 tool
6.35 (1/4")	0-0.5	1.0
9.52 (3/8")	0-0.5	1.0

2. Pipe Connection

- Remove the flare nut from the pipe of the indoor unit by removing the flare nut (female side) with a spanner while holding down the half union (male side) with a spanner.
- Do not crush the pipe while bending it.
- Apply refrigerant oil on the connection part. After carrying out the center alignment and manual tightening of the flare nut, tighten the flare nut securely with a torque wrench (spanner).

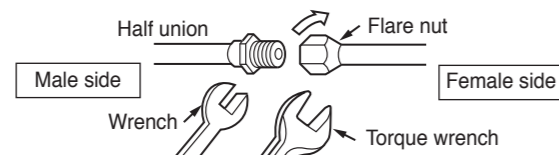

* Tightening torque must be as shown in the table below.

	Outer diameter of pipe (ø)	Torque N·m (kgf·cm)
Small diameter side	6.35 (1/4")	13.7-18.6 (140-190)
Large diameter side	9.52 (3/8")	34.3-44.1 (350-450)
Small diameter side	6.35 (1/4")	19.6-24.5 (200-250)
Large diameter side	9.52 (3/8")	19.6-24.5 (200-250)
Valve head cap		12.3-15.7 (125-160)

CAUTION

- When removing flare nut of the indoor unit, first remove the nut of small diameter side. Otherwise the nut of big diameter side will fly out.
- Prevent water from entering into the piping when connecting.
- Be sure to tighten the flare nut to the specified torque with a torque wrench. If the flare nut is over-tightened, it may split after sometime and may cause refrigerant leak.
- When using a control valve, make sure that the packing is not deteriorated and avoid excessive tightening of the handle. Otherwise, gas may leak from the service valve.

3. Remove of Air from the Pipe and Gas Leakage Inspection

From the viewpoint of global environment protection, air purge type should be vacuum pump method.

- Fully tighten the "Hi" shuttle of the manifold valve and completely unscrew the "Lo" shuttle. Run the vacuum pump. (Adapter is switched on)
- After pumping for about 10-15 minutes, completely tighten the "Lo" shuttle and switch off the vacuum pump. (Adapter is switched off)

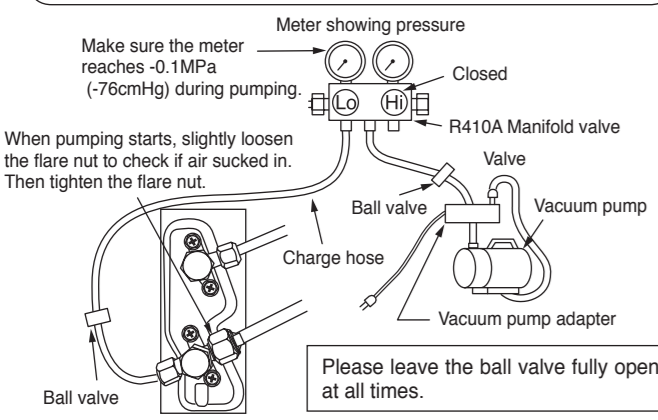

- Remove the valve head cap of the service valve.
- Remove the cap of valve core and connect the charge hose.
- Connect the vacuum pump adapter to the vacuum pump and connect the charge hose to the adapter.
- Loosen the spindle of the service valve with small diameter by 1/4 turn and tighten the spindle immediately after 5 to 6 seconds.
- Remove the charging hose from the service valve.
- Unscrew the spindle of both the service valves in anticlockwise direction to allow the flow of refrigerant (unscrew halfway).
- Tighten the cap of valve head. Check and make sure that there is no gas leakage.

Gas Leakage Inspection

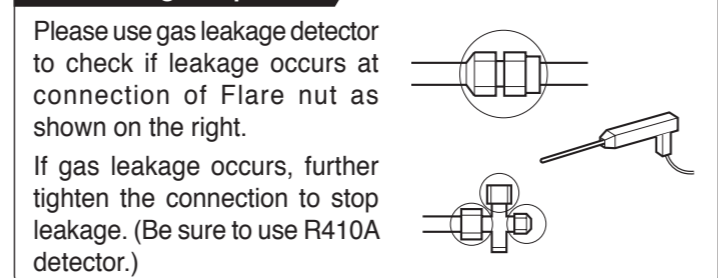

Works to be done when transferring or removing air conditioner

- From the viewpoint of global environment protection, refrigerant should be recovered (pumped down) when the air conditioner is transferred or removed.
- Perform force-cooling operation (refer to "Force-cooling operation" on page 12) for about 5 minutes as a preliminary operation.
 - Tighten the spindle of the service valve at small diameter side in clockwise direction.
 - Continue the force-cooling operation for another 1-2 minutes, and then tighten the spindle of the service valve at large diameter side in clockwise direction.
 - Stop the force-cooling operation.

Procedures of Wiring

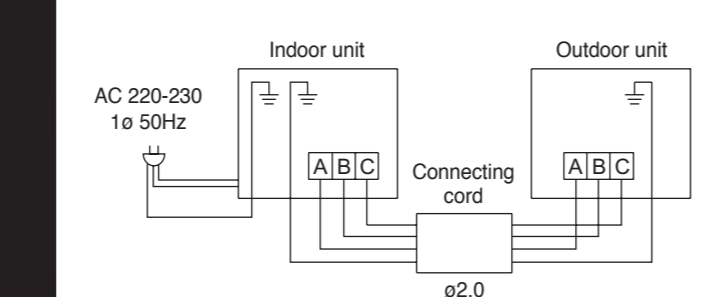

Detail of Cutting the Connecting Cord

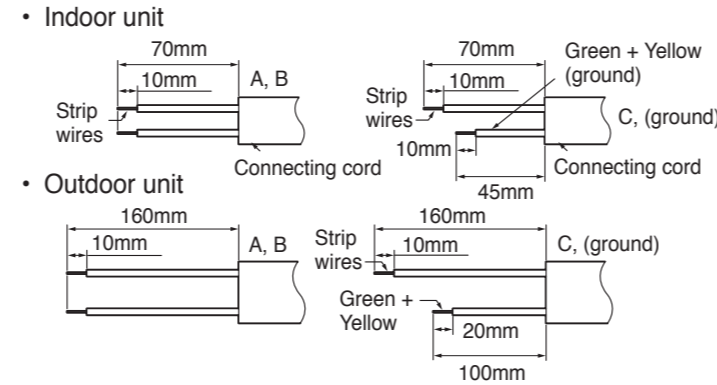

WARNING

- The naked part of the wire core should be 10mm fit to the terminal tightly. Then try to pull the individual wire to check if the contact is tight. Improper insertion may burn the terminal.
- Be sure to use only wire specified for the use of air-conditioner.
- Please refer to the manual for wire connection, the wiring technique should meet the standard of the electrical installation.
- Leave some space in the connecting cord for maintenance purpose and be sure to secure it with the cord band.
- Secure the connecting cord along the coated part of the wire using the cord band. Do not exert pressure on the wire as this may cause overheating or fire.

Wiring of the Indoor Unit

- Remove the front panel. (Refer to "Removing and Attaching the Front Panel" on page 13)
- Remove the terminal cover and screw, hold the upper part when removing.

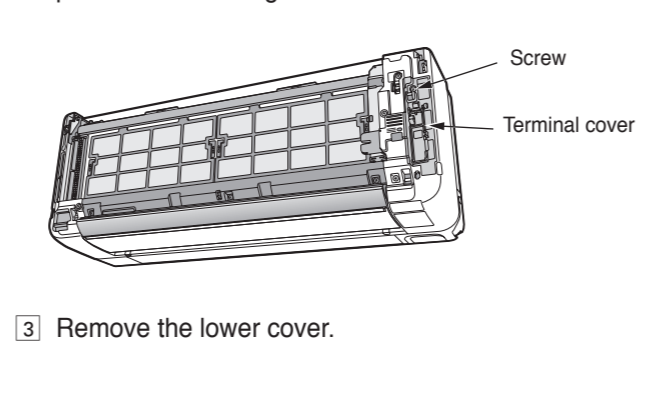

- Bring the connecting cord from the rear surface to the front surface through the cable guide.
- Connect the connecting cord and fix with cord band.
- Hook onto the claw at the lower part of the terminal cover and fix with screw.

1. Heat Insulation and Finishing of Piping

- Cover the pipe connection with the auxiliary insulation sheet, wrap the tape without any gap.
- If there is gap or over-tightened, it may cause condensation.
- Please wrap the pipe and power cord together with vinyl tape as shown in the figure of the installation of indoor and outdoor units on page 2.
- To enhance the heat insulation and to prevent water condensation, please cover the outdoor part of the drain hose and pipe with insulation sheet.
- When using an exit cover, do not attach a bush for pipe.
- When an exit cover is not used, seal the gap of the hole on the wall, bush and pipe completely with putty. If an exit cover is used, seal the gap of the hole on the wall and pipe completely with putty. In the case of embedded piping, seal the gap of the pipe completely with putty. Incomplete sealing could cause entering of high humidity air into the wall or indoor unit, which could result in dripping of dew. It could also cause small or odor present outdoor and inside the wall spreading into the room.

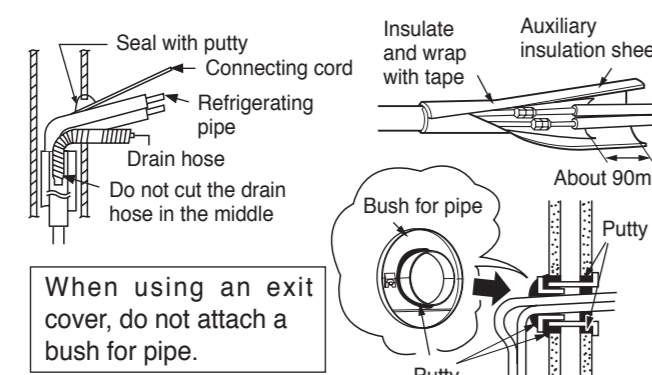

CAUTION

- Completely seal any gap with putty. High humidity air inside the wall or the outdoor may go in to the room and could result in dripping of dew. It could also cause small or odor present outdoor and inside the wall spreading into the room.

2. Affixing the Remote Controller and Installing the Anti-mold Wasabi Cassette

- The remote controller may be affixed to a wall or pillar with the remote controller mounting screw.
- When operating the air conditioning with the remote controller attached, please make sure that the signal is received by the air conditioning. Furthermore, fluorescent lighting may affect the reception of the signal, therefore, please make sure by turning on the fluorescent lighting even during the day.
- Lighting fixtures with electronic starters may shorten the reception distance and may even interfere with the signal being received.

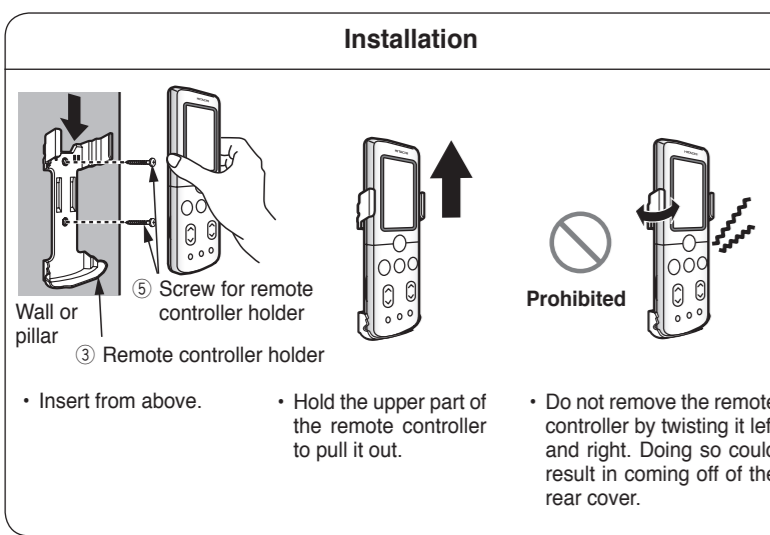

- Install the anti-mold wasabi cassette. (Refer to page 8 of the Operation Manual)
- Noise may occur if the anti-mold wasabi cassette is not installed properly.

3. Remove the Protection Sheet

- Remove the protection sheet on the display panel.

4. Power Source and Operation Test

- Power source**
- WARNING**
- Never modify or extend the power cord.
 - Keep additional length for the power cord and do not render the plug under external force as this may cause poor contact.
 - Do not fix the power cord with U-shape nail.
 - The power cable easily generates heat. Do not bring the cable together with a wire or vinyl tie.
- CAUTION**
- Use a new power outlet. Old power outlet may cause insufficient electrical contact, which could result in unforeseen accident.
 - Connect and disconnect the power plug a few times to ensure smooth plug-in before completely insert the power plug into the power outlet.
- Operation test**
- Please ensure that the air conditioner is in normal operating condition during the operation test.
 - Explain to your customer about the proper operation procedures as described in the operation manual.
 - If the indoor unit won't operate, check the cable for correct connection.

- Force-cooling operation**
- When the temporary switch of the indoor unit is pressed for more than 5 seconds, the force-cooling operation starts. Use this mode when performing the failure diagnosis or collecting refrigerant into the outdoor unit.
 - The Timer lamp flashes when force-cooling is in operation.
 - Press the temporary switch again or use the remote controller to stop the force-cooling operation once this operation is completed.

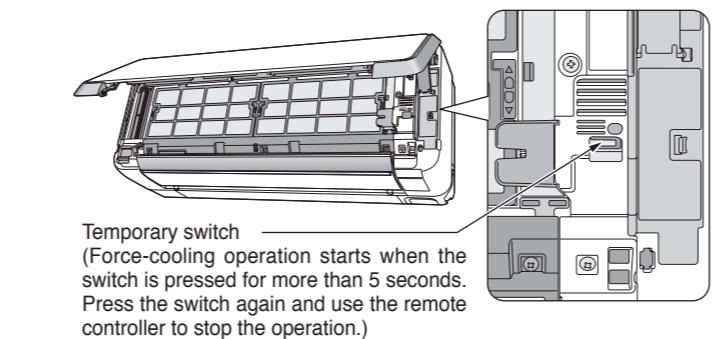

CAUTION

- Do not operate the unit for more than 5 minutes while the spindle of the service valve is closed.

Removing and Attaching the Front Panel

- Be sure to hold the front panel with both hands to detach and attach it.

Please refer to the operation manual on how to open and close the front panel.

CAUTION

- Please do not use excessive force to open and close the movable panel by hands. This may cause malfunction. (The movable panel automatically open and close when the power is ON/OFF and START/STOP.)

Removing

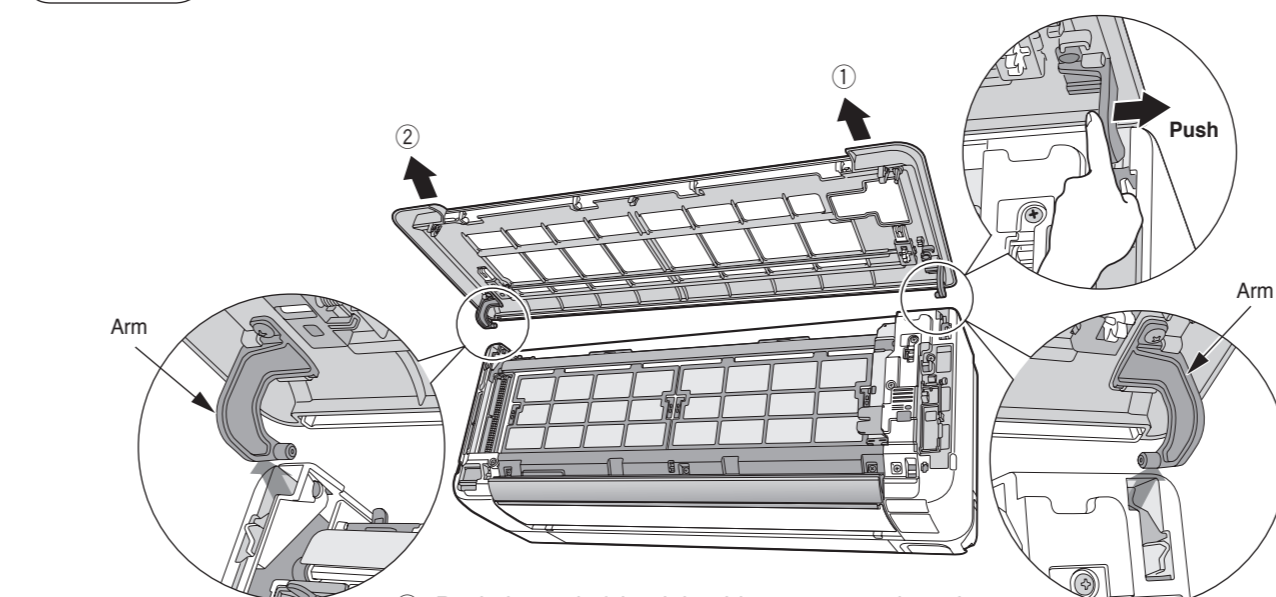

- Push the end of the right-side arm outward to release the tab.
- Move the left-side arm outward to release the left tab, and then pull the panel towards you.

Attaching

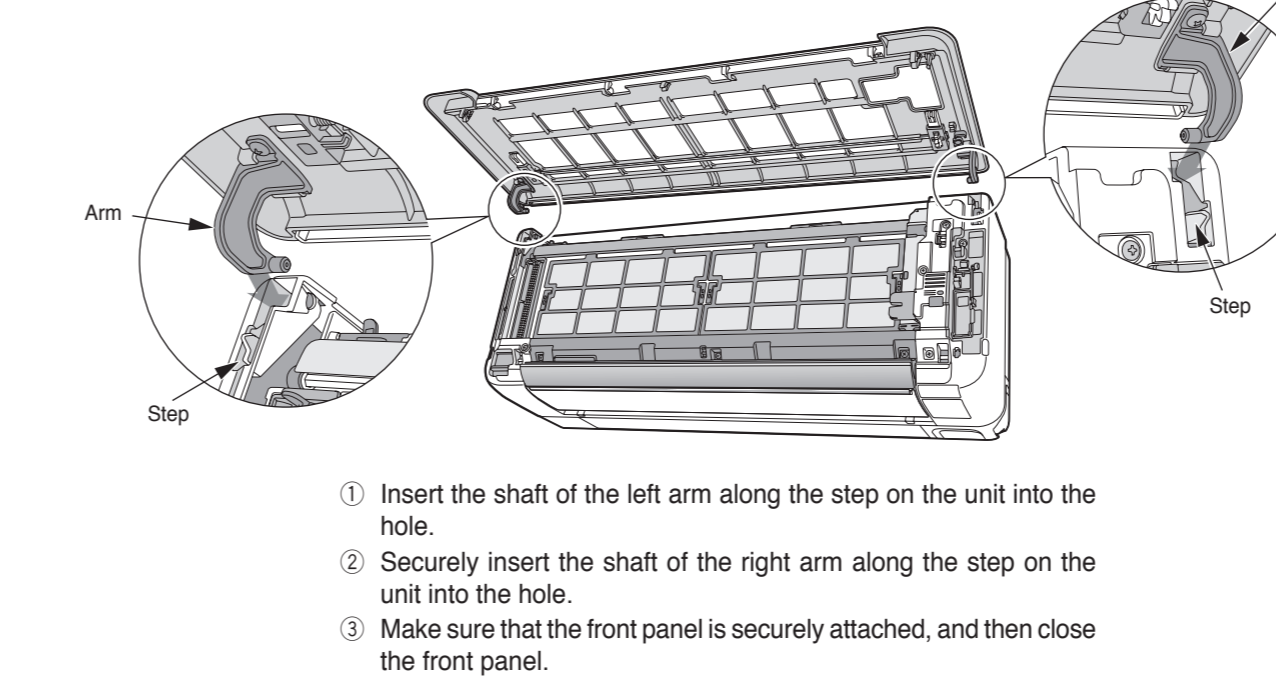

- Insert the shaft of the left arm along the step on the unit into the hole.
- Securely insert the shaft of the right arm along the step on the unit into the hole.
- Make sure that the front panel is securely attached, and then close the front panel.

CAUTION

- Once the installation work has been completed, close the front panel and insert the power plug into the power outlet, and then carry out "Filter Cleaning Operation Check".

Filter Cleaning Operation Check

- After the installation work has been completed, be sure to carry out "Filter Cleaning Operation Check" before performing trial run (cooling or heating)!

- Before turning on the power of the air conditioner, make sure that the filters (2 pieces at the top and 2 pieces in front) have been installed properly and locked.
- When the power of the air conditioner turns on, the "Filter Cleaning Operation" starts automatically. The "Clean" indicator is lit during the filter cleaning operation.

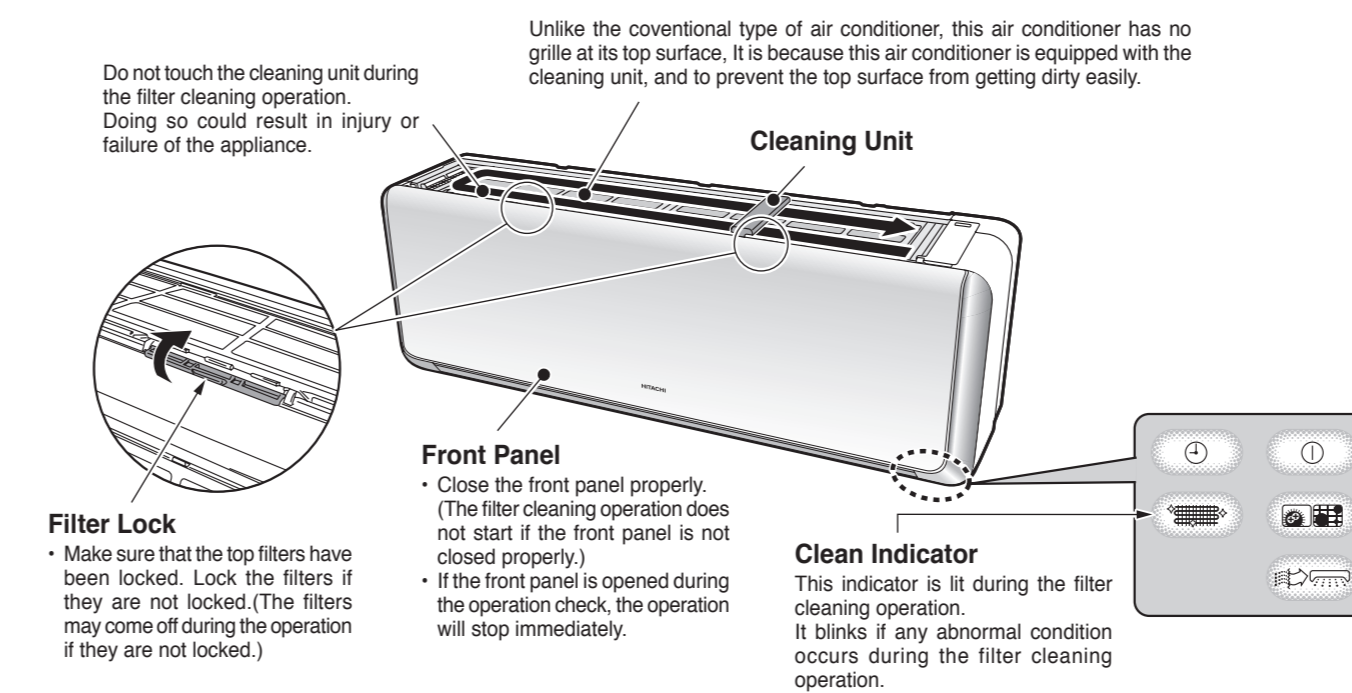

Filter Lock

- Make sure that the top filters have been locked. Lock the filters if they are not locked. (The filters may come off during the operation if they are not locked.)

Clean Indicator

- This indicator is lit during the filter cleaning operation. It blinks if any abnormal condition occurs during the filter cleaning operation.
- Filter cleaning operation check will take approximately 7 minutes for the cleaning unit to make one cycle of back and forth movement. Make sure that the cleaning unit is actually working by a visual inspection from the top of the indoor unit.
- Close the front panel properly. (The filter cleaning operation does not start if the front panel is not closed properly.)
- If the front panel is opened during the operation check, the operation will stop immediately.
- If the "ON/OFF" button on the remote control is pressed during the operation check, the operation check is stopped before its completion. Wait until the operation check is completed without pressing any button on the remote controller.
- If the filters are not installed properly, "Filter Cleaning Operation" is found abnormal and the "Clean" indicator blinks. The filters may come off during operation if they are not installed properly.

- If the "Clean" indicator blinks during the "Filter Cleaning Operation" means that the operation is stopped before its completion due to an abnormal condition. In this case, refer to "Check the Operation of the Filter Cleaning Unit" and "Troubleshooting" of the operation manual and take appropriate actions.

Removing the Front Cover

- Remove the front panel.
- Remove the screw cover at the bottom of the front cover and remove the screw.
- Remove the screws on the terminal cover, on the left side of the front cover and the screw on the right side.

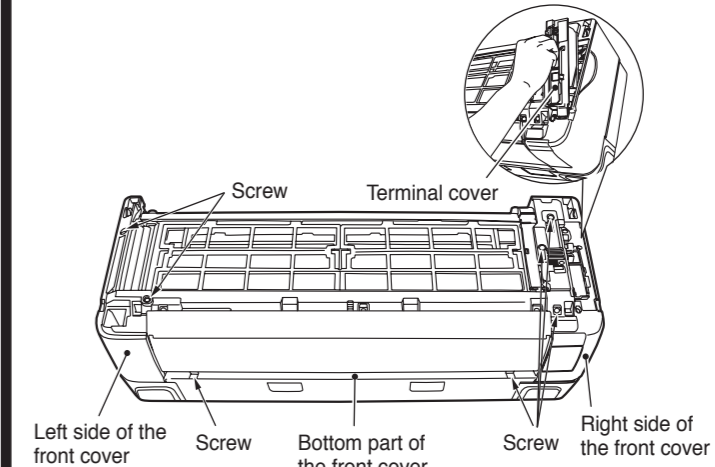

- Remove the bottom part of the front cover by pulling it forward.
- Hold onto the left side of the front cover and remove while pulling in the direction of the arrow.

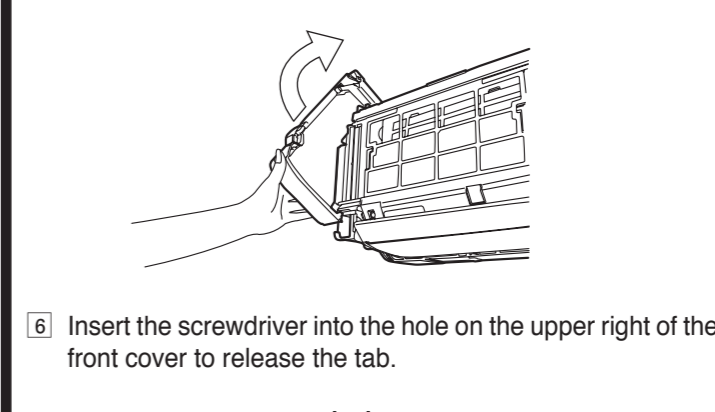

- Insert the screwdriver into the hole on the upper right of the front cover to release the tab.
- Hold onto the right side of the front cover and remove while pulling in the direction of the arrow.

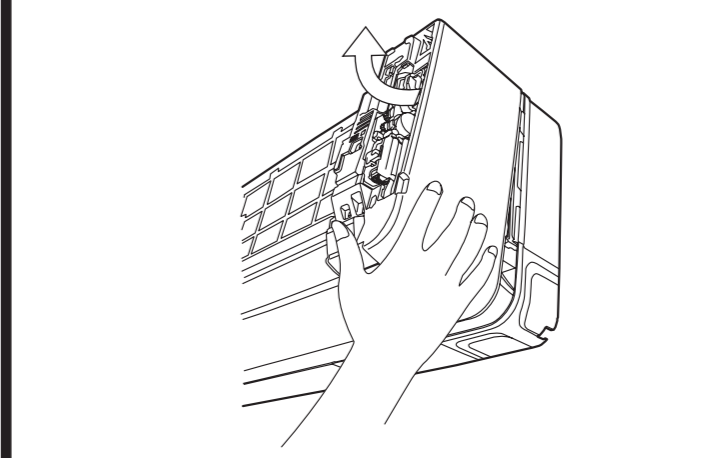

Attaching the Front Cover

- Make sure that the dew receiving pan and the cleaning unit are securely attached.
- After attaching the left and right sides of the front cover onto the unit, ensure that the top tabs (2 places) have been fixed.

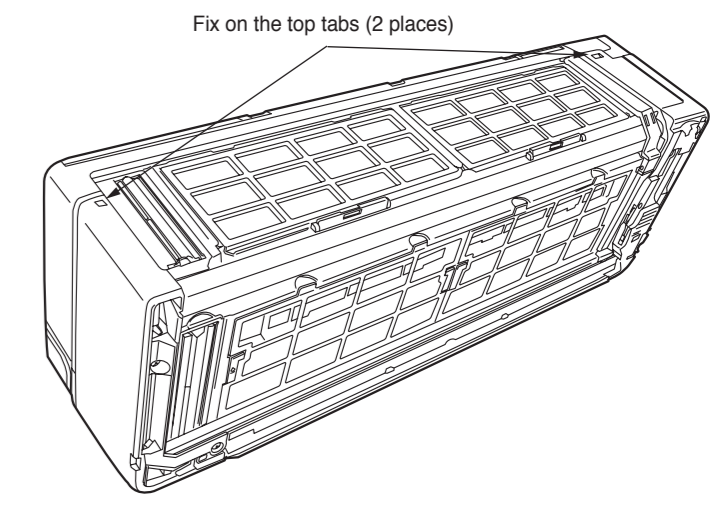

- Tighten the screws on the terminal cover and on the left and right sides of the front cover.
- Tighten the screws at the bottom of the front cover and replace the screw cover.

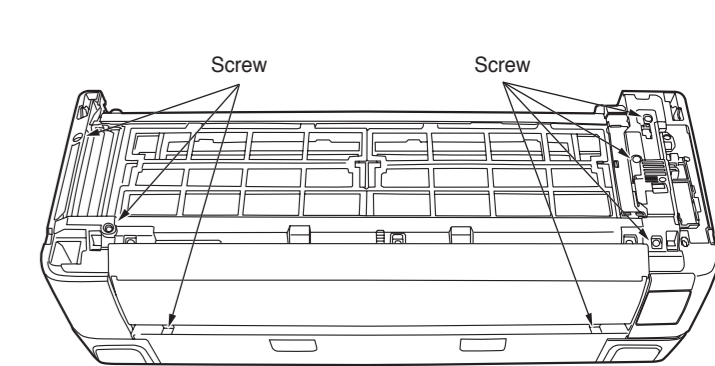

- Attach the front panel.

How to check Micro Mesh Stainless Filter installation

- Remove the front panel and check if the filter locks (4 pcs) are tripped or slant.
- If the filters are not inserted properly, refer to following "Installing the Micro Mesh Stainless Filters".
- Please perform "Filter cleaning operation check" again after reinstalled the filters.

Installing the Micro Mesh Stainless Filters

- Slide the locks (2 places each on the left and right) of the micro mesh stainless filters upwards.
- Align the filter with the top face of the indoor unit, and then slide and push it in. (The shape of the left and right filters are the same.)

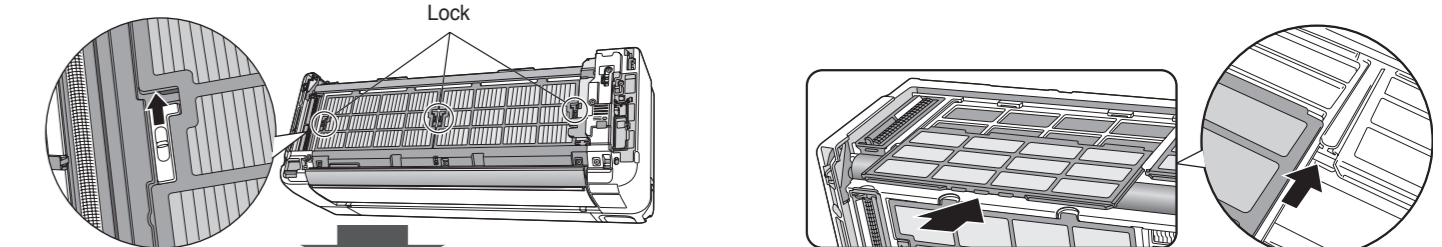

- Place the micro mesh stainless filter with its side having indication of [UPPER FILTER] and [BACK] facing towards the unit. (The shape of the left and right filters are the same.)
- Insert the bottom side of micro mesh stainless filter (left and right), then slightly bend and insert it in the arrow direction.
- Push up the filter lock (both side) on the top surface.

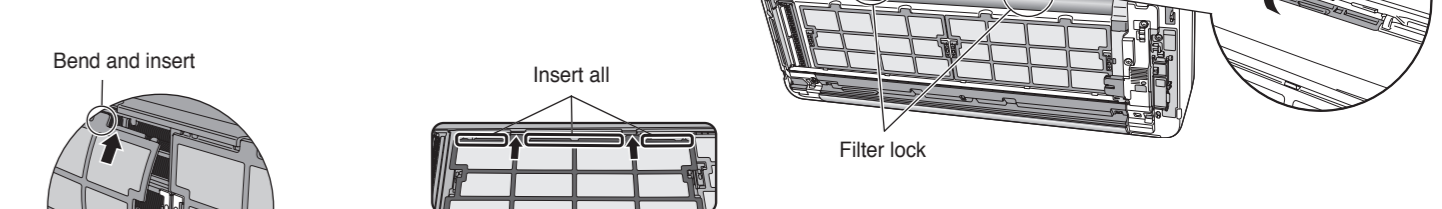

H-LINK

- [For all optional part, please refer catalog for part number]
- As for connecting to H-Link, a separately purchased RAC Adapter is required.
- To install the wiring, the electrical box cover must be opened.
 - Connect the connector of RAC Adapter to CN7.
 - Assemble back the cover of electrical box.
 - Please refer to the respective user manual of RAC Adapter for further details.
 - Please be careful not to damage lead wires by edge of plate when connecting the optional parts.
 - You can refer to this installation manual on how to remove and re-attach the front cover.

