

HITACHI







INVERTER SYSTEM MULTI TYPE

INDOOR UNIT





INSTALLATION MANUAL

MODEL  RAD-18NHA1
RAD-25NHA1
RAD-35NHA1
RAD-50NHA1

- Carefully read through the procedures of proper installation before starting installation work.
- The sales agent should inform customers regarding the correct operation of installation.
- Explanation for outdoor unit is in the "How To Use" (Instruction Manual) that packed with outdoor unit.

- Tools Needed For Installation Work**
(Mark  is exclusive use tool for R410A)
-   Screwdriver • Measuring Tape • Knife • Saw • ϕ 65mm Power Drill • Hexagonal Wrench Key ($\frac{1}{4}$ " 4mm) • Wrench (14, 17, 22, 26mm) •  Gas Leakage Detector • Pipe Cutter • Putty • Vinyl Tape • Pliers • Flare Tool •  Vacuum Pump Adapter • Manifold Valve •  Charge Hose •  Vacuum Pump

SAFETY PRECAUTION

- Read the safety precautions carefully before operating the unit.
 - The contents of this section are vital to ensure safety. Please pay special attention to the following sign.
 -  **WARNING** Incorrect methods of installation may cause death or serious injury.
 -  **CAUTION** Improper installation may result in serious consequence.
 -  **Make sure to connect earth wire.**
 -  **This sign in the figures indicates prohibition.**
- Be sure that the unit operates in proper condition after installation. Explain to customer the proper way of operating the unit as described in the user's guide.

WARNING

- Please request your sales agent or qualified technician to install your unit. Water leakage, short circuit or fire may occur if you do the installation work yourself.
- Please observe the instructions stated in the installation manual during the process of installation. Improper installation may cause water leakage, electric shock and fire.
- Make sure that the units are mounted at locations which are able to provide full support to the weight of the units. If not, the units may collapse and impose danger.
- Observe the rules and regulations of the electrical installation and the methods described in the installation manual when dealing with the electrical work. Use wire which are approved official in your country. A short circuit and fire may occur due to the use of low quality wire or improper work.
- Be sure to use the specified wire for connecting the indoor and outdoor units. Please ensure that the connections are tight after the conductors of the wire are inserted into the terminals. Improper insertion and loose contact may cause over-heating and fire.
- Please use the specified components for installation work. Otherwise, the units may collapse or water leakage, electric shock and fire may occur.
- When installing or transferring an air conditioner to another location, make sure that air other than the specified refrigerant (R410A) does not enter the refrigeration cycle. If other air should enter, the pressure level of the refrigeration cycle may increase abnormally which could result in a rupture and injury.
- Be sure to use the specified piping set for R410A. Otherwise, this may result in broken copper pipes or faults.
- When installing or removing an air conditioner, do not allow air or moisture to remain in the refrigeration cycle. Otherwise, pressure in the refrigeration cycle may become abnormally high so that a rupture may be caused.
- Be sure to ventilate fully if a refrigerant gas leak while at work. If the refrigerant gas comes into contact with fire, a poisonous gas may occur.
- After completion of installation work, check to make sure that there is no refrigeration gas leakage. If the refrigerant gas leaks into the room, coming into contact with fire in the fan-driven heater, space heater, etc., a poisonous gas may occur.
- Unauthorized modifications to the air conditioner may be dangerous. If a breakdown occurs please call a qualified air conditioner technician or electrician. Improper repairs may result in water leakage, electric shock and fire, etc.
- Be sure to connect the earth wire from the power supply wire to the outdoor unit and between the outdoor and indoor unit. Improper earthing may cause electric shock.

CAUTION

- A circuit breaker must be installed in the house distribution box for the direct connected power supply wire to the outdoor unit. In case of other installations a main switch with a contact gap or more than 3mm has to be installed. Without a circuit breaker, the danger of electric shock exists.
- Do not install the unit near a location where there is flammable gas. The outdoor unit may catch fire if flammable gas leaks around it. Piping shall be suitable supported with a maximum spacing of 1m between the supports.
- Please ensure smooth flow of water when installing the drain hose.
- An IEC approved power cord should be used. Power cord type: NYM.

THE CHOICE OF MOUNTING SITE

(Please note the following matters and obtain permission from customer before installation.)

WARNING

- The unit should be mounted at stable, non-vibratory location which can provide full support to the unit.

WARNING

- No nearby heat source and no obstruction near the air outlet is allowed.
- The clearance distances from top, right and left are specified in figure below.
- The location must be convenient for water drainage and pipe connection with the outdoor unit.
- To avoid interference from noise, please place the unit and its remote controller at least 1m from the radio and television.
- To avoid any error in signal transmission from the remote controller, please put the controller far away from high-frequency machines and high-power wireless systems.

Accessories to indoor Unit:

No.	Item	Quantity
①	Flare Insulator	1
②	Binder	2
③	4.0 x 10 Screw	2
④	Insulation Pipe	1
⑤	Holder for Remote Controller	1
⑥	3.1 x 16 Screw	2
⑦	AAA Size Battery	2
⑧	Aluminium Tape (large)	1
⑨	Remote Controller	1
⑩	Band	1
⑪	Suspension Clamp (right, left) each	2
⑫	4.0 x 10 Screw	8
⑬	Panel Installation Plate	1
⑭	Panel Cover	1

[Indoor unit installation]

CAUTION

Always install the indoor unit level. Units not installed level may leak.

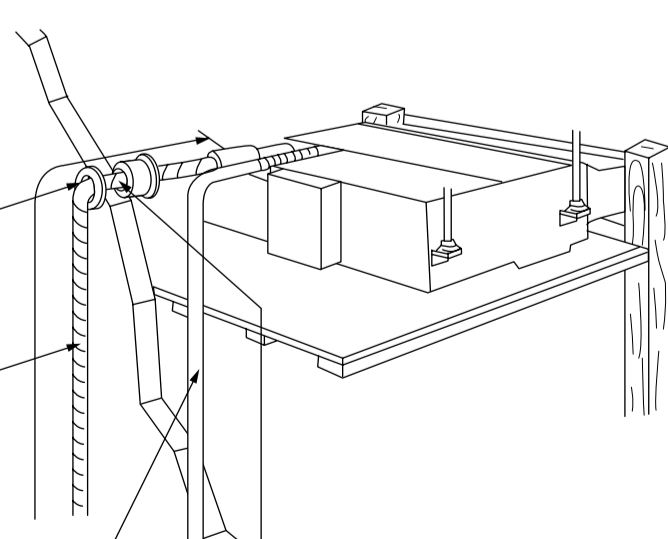

Be sure to completely seal any gap with putty.

• Adiabated pipes must always be used for both large and small diameter. Wrap pipes with tape. An adiabator will weather excessively if not tape-wrapped.

Drain pipe
Must be installed separately.
Insulate indoor part of pipe to prevent condensation.

The indoor piping should be insulated with the enclosed insulation pipe. (If the insulator is insufficient, please use commercial products.)

• Use the holder when the pipe is drawn from the left.

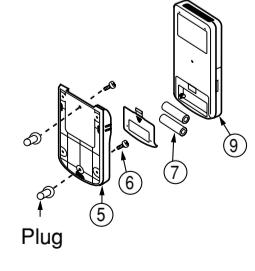

- "Height difference" and "Piping length" of Indoor and Outdoor unit are different by Outdoor unit. Please refer to the installation manual in Outdoor unit.

TYPE OF INDOOR UNIT

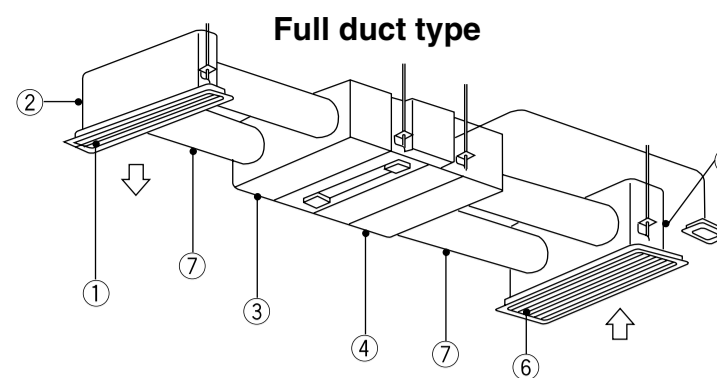

Need optional parts when install full duct type

①	Discharge grille	RAU-FG2
②	Chamber of discharge grille ϕ 150mm	RAU-GD2
③	Chamber of discharge of unit side ϕ 150mm	RAU-DU2
④	Chamber of suction of unit side ϕ 150mm	RAU-DU1
⑤	Chamber of suction grille ϕ 150mm	RAU-GD1
⑥	Suction grille	RAU-FG1
⑦	Flexible duct ϕ 150mm 1m Flexible duct ϕ 150mm 2m	RAU-FD1 RAU-FD2

Semi duct type

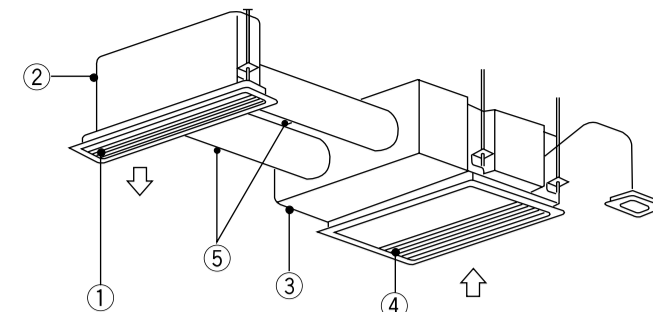

Need optional parts when install semi duct type

①	Discharge grille	RAU-FG2
②	Chamber of discharge grille ϕ 150mm	RAU-GD2
③	Chamber of discharge of unit side ϕ 150mm	RAU-DU2
④	Suction grille	RAU-FG11
⑤	Flexible duct ϕ 150mm 1m Flexible duct ϕ 150mm 2m	RAU-FD1 RAU-FD2

Non duct type

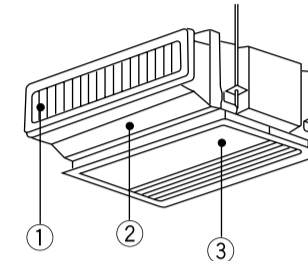

Need optional parts when install non duct type

①	Discharge grille	RAU-FG21
②	Discharge duct	RAD-BD
③	Suction grille	RAU-FG11

1. Proper place for installation

1.1 Indoor unit

Refrigerating pipes can be drawn from the back, the under the left side of the indoor unit. In the case that refrigerating pipes are drawn from the left side, confirm the smooth flowing of condensed water. If not, the condensed water will overflow into the room. When the pipes are drawn from the right or the left side, the pipes can be connected easily by configuring the pipes before installation.

2. Installation procedure and notice

Especially, the selection of installation place need great care for the split type air conditioner, because it is very difficult to move from place to place after the first installation.

2.1 Make a hole on the wall such the place as shown in Fig. 2-1, in order to keep the flow condensed water smooth.

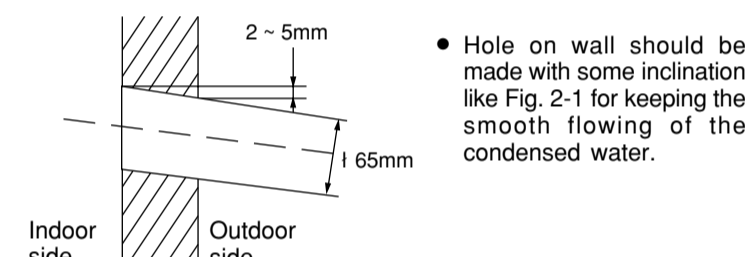

Fig. 2-1

2.2 Connecting pipe installation

- Seal the end of pipes to prevent from moisture and water.

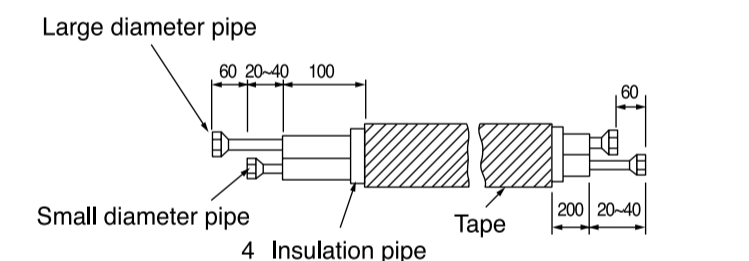
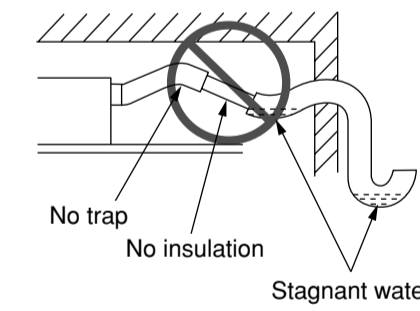
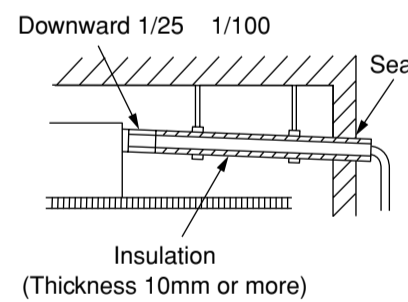

Fig. 2-2

(Unit: mm)

2.3 Drain pipe installation

- Use PVC pipe VP20 (O.D. 25mm) for drain pipe.
- Be sure to roll a insulation (thickness 10mm or more) for the drain pipe at indoor side.
- Draw the drain pipe that makes always downward for the water flow smoothly. And fix it (ex. by hanger) not to make a peak and trap.



Do not do the installation as shown as above

Fig. 2-3

2.4 Installation method of unit type

INSTALLATION OF FULL DUCT TYPE

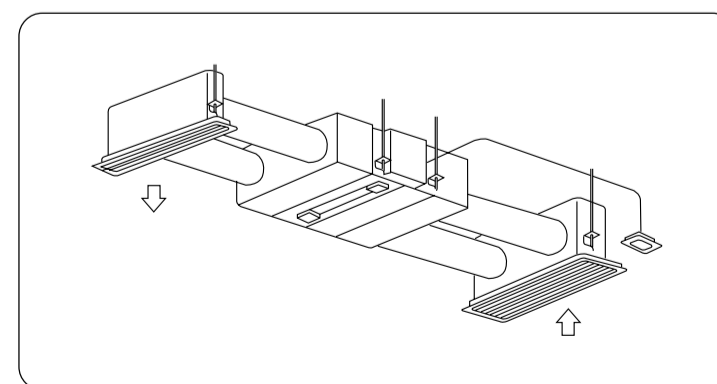

- Select the indoor unit position, fixing direction of air outlet so that cool/hot air reaches all the room. Standard position of the indoor unit is with the wall side on the ceiling.

- Permissible length and bending of duct.

	Permissible length	Bending
Discharging side duct	4m or less added to suction side	90° or less, 1 section
Suction side duct	1m or less	45° or less, 1 section

- Secure the space for installation, inspection or servicing.
- Apply water-proof treatment to back surface of ceiling under the indoor unit, to prevent water drop.
- Do not allow any obstacle to block air flow within 1m of suction grille.

(1) Installation figure

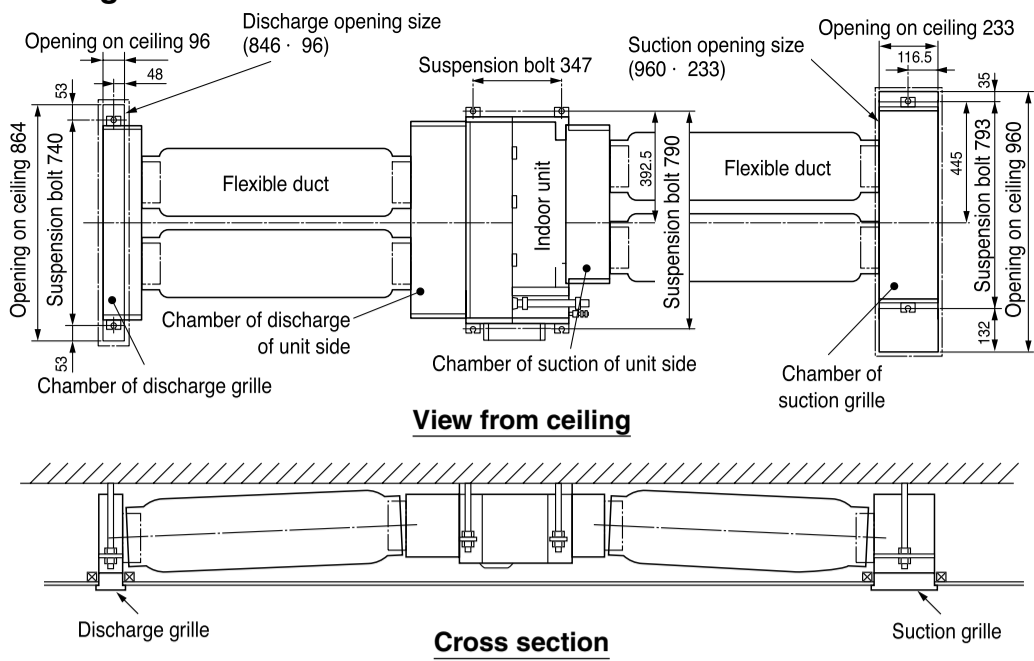

(Unit: mm)

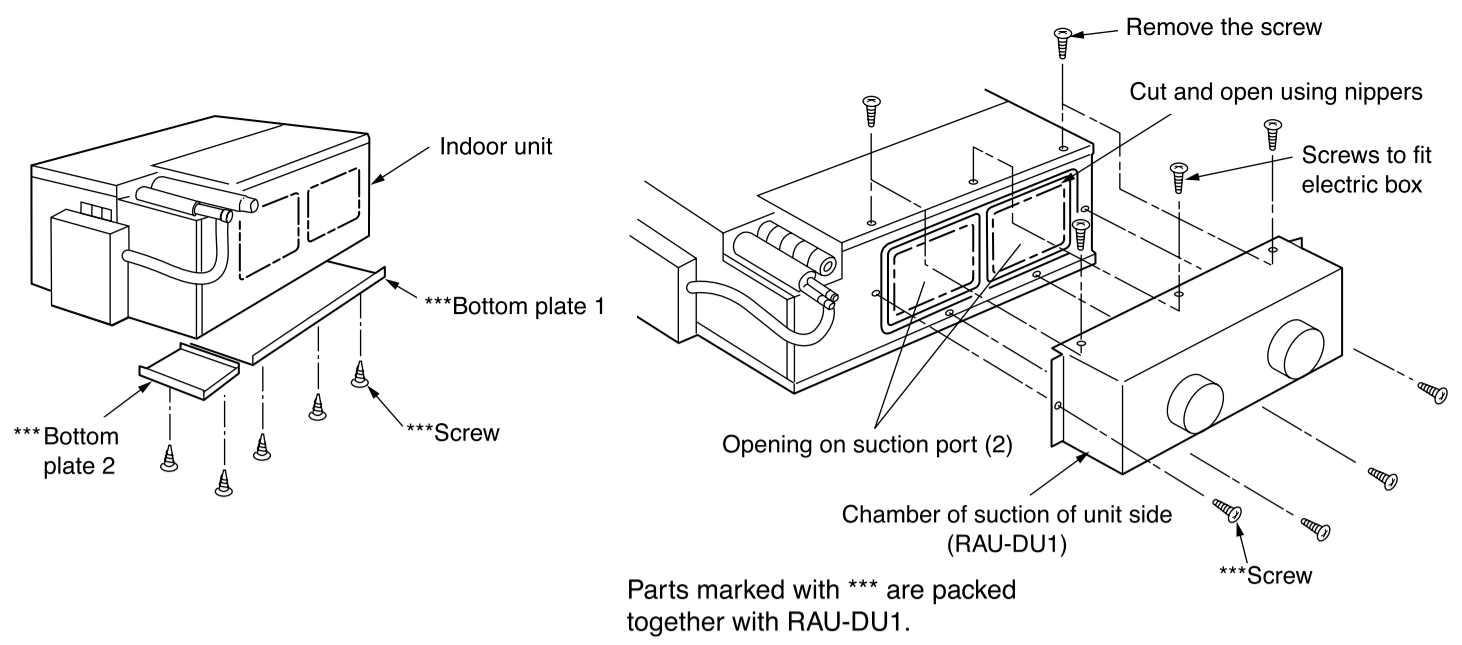

(2) Opening on ceiling and suspension bolt position

• Indoor unit

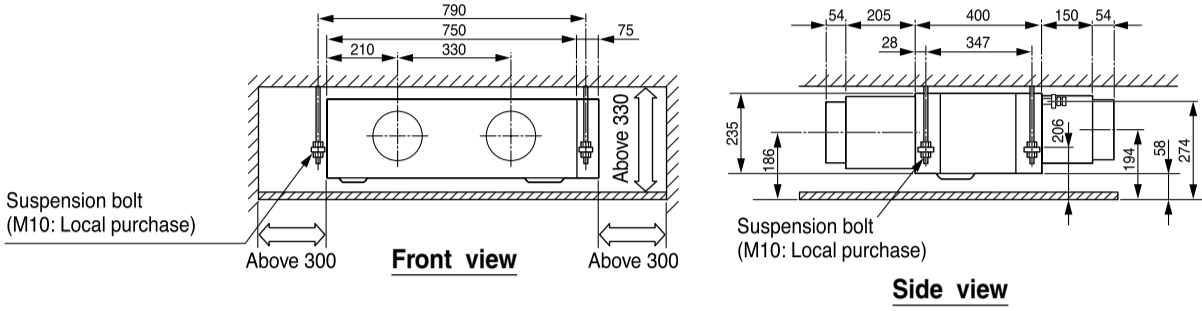

• Chamber of suction grille

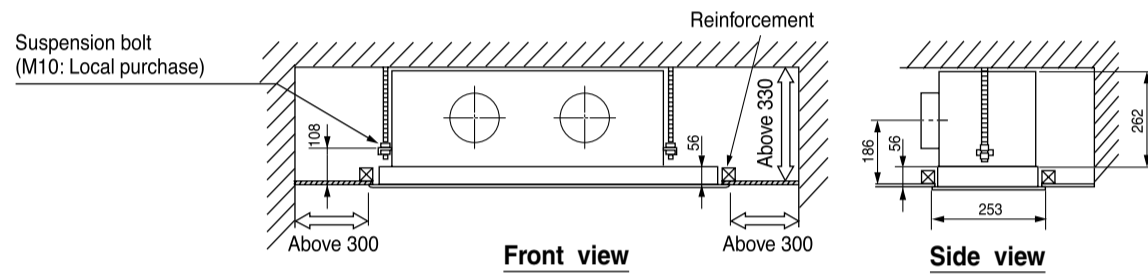
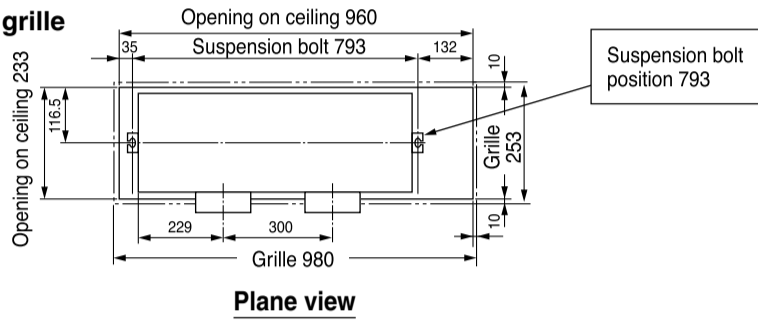

• Chamber of discharge grille

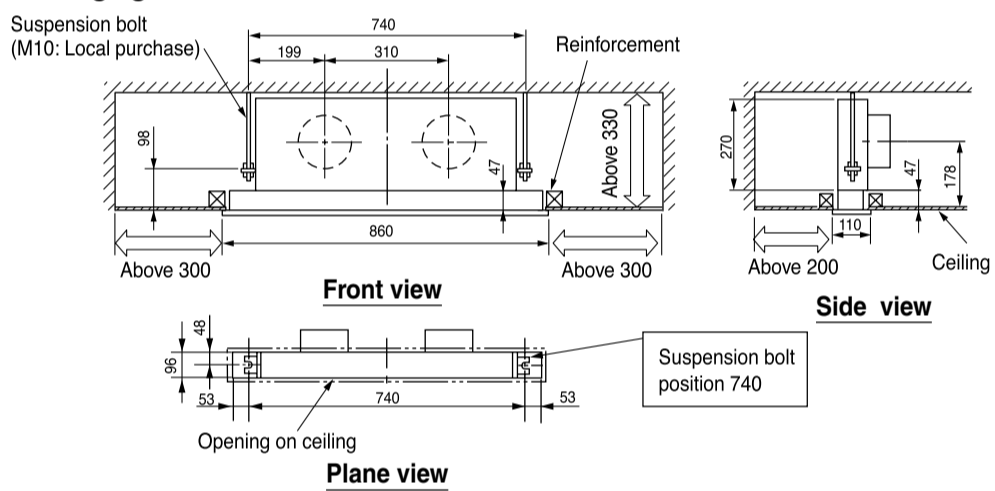

- Arrange drain pipe, refrigerant pipe and connecting cord in their installation position.
- For finishing of opening on ceiling, arrange with builder in detail.

(3) Installation of suspension bolt

- Be sure to reinforce furring of ceiling (frame: ceiling joint and supporter) to maintain level of ceiling and prevent vibration of ceiling plate.
- Suspension bolts should be purchased in the field.
- Refer to diagrams shown below for length of suspension bolts.

• In case of wooden frame

60~90mm square piece of lumber

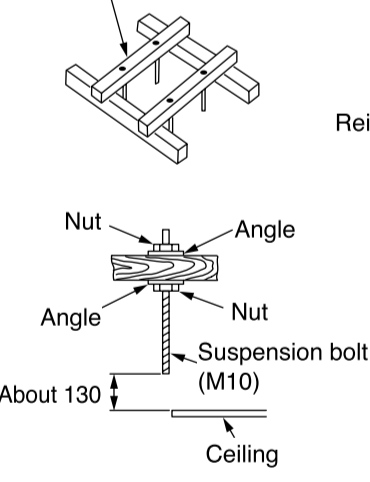

• In case of steel frame

150~160mm Insert (100~150kg)

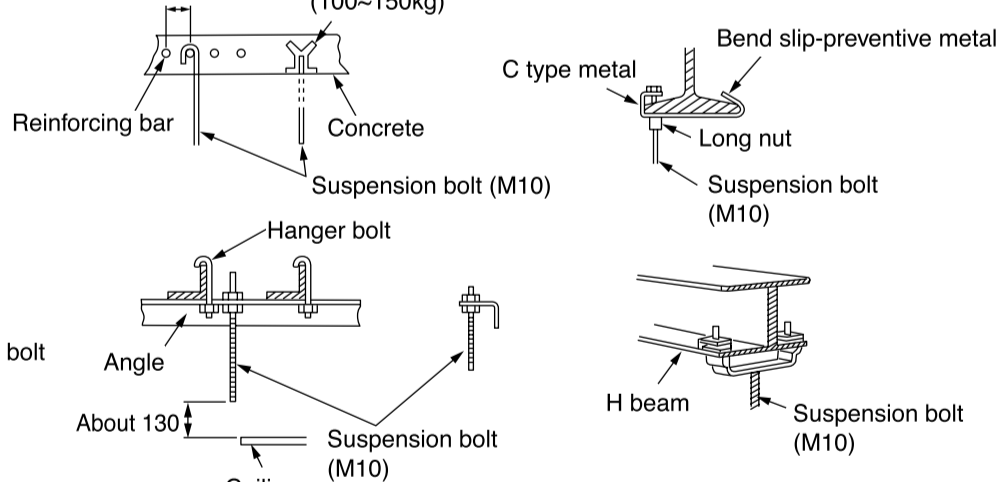

(Unit: mm)

(4) Preparation for installing indoor unit

- Remove 1 screw by which electric box is installed, and then remove electric box.
- Turn removed electric box with lead wires kept connected so that wire lead out section is positioned at the upper side, and hook the claw of electric box to side plate. Then fix the electric box to the bottom of the indoor unit using 1 screw.
- Install 4 suspension clamps at both sides of indoor unit, 2 clamps at each side, using 8 tapping screws. (Since size of left and right clamps are different for certain parts, refer to diagram on the right.)
- Chamber of discharge of unit side (optional part: RAU-DU2) on the indoor unit using 10 tapping screws.

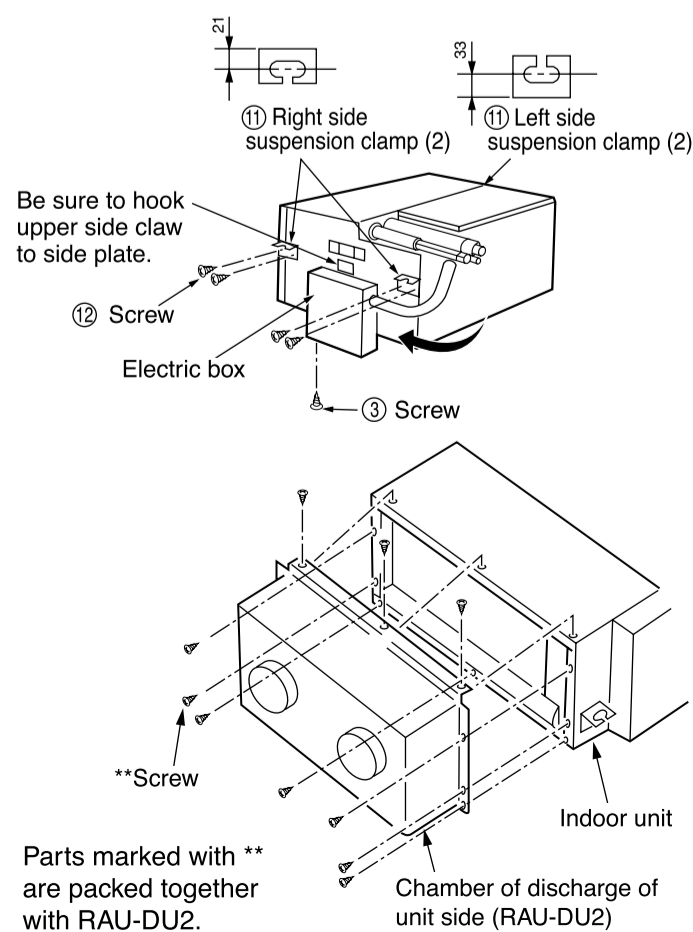

- Install bottom plates 1 and 2 on the bottom of the indoor unit using 9 tapping screws. (Install bottom plate 1 first, followed by plate 2.)
- Cut and open dotted line section for suction port at the back of the indoor unit, using nippers (2 locations).
- Remove 2 screws at top plate end of indoor unit and chamber of suction of unit side (RAU-DU1) using 7 screws.

(5) Installation of indoor unit

- Set nut and washer on suspension bolt and hook it to suspend clamp by lifting the indoor unit.
- Make sure that indoor unit is kept level using a level or vinyl hose with water.
- Fix the indoor unit so that the space between bottom surfaces of ceiling and indoor unit is 58mm.

[Installation of chamber of suction grille (RAU-GD1)]
 [Installation of chamber of discharge grille (RAU-GD2)]
 [Installation of suction grille (RAU-FG1)]
 [Installation of discharge grille (RAU-FG2)]
 [Installation of flexible duct (RAU-FD1, 2)]
 Refer to installation manual of optional part.

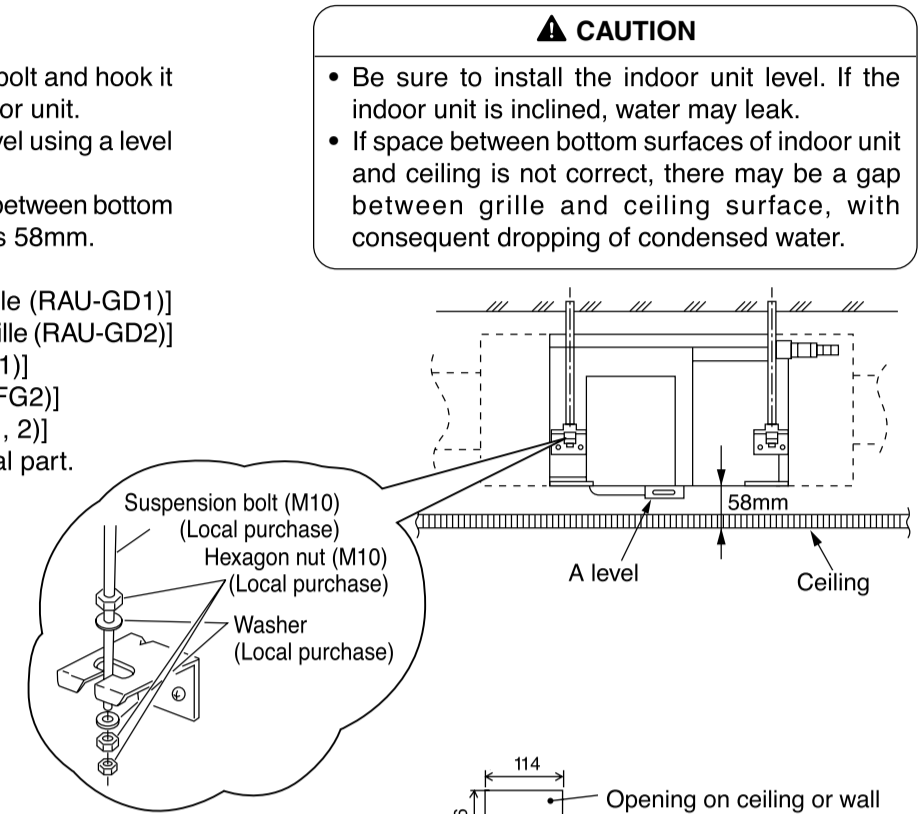

(6) Installation of display panel

- Select an installation position on ceiling or wall where there is no obstacle to interrupt signal reception.
- Loosen screws of panel installation plate so that bracket can be slightly moved.
- Match the display panel to panel installation plate so the fixing claws on the panel are securely hooked.
- Match brackets to the opening on ceiling or wall and tighten screws until bracket is firmly secured to ceiling material.
- Install the panel cover so inside claws are securely hooked to the panel installation plate.
- Conduct the indoor unit side housing of display panel cord to the electric box of the indoor unit and connect it with the housing at the side of the unit.

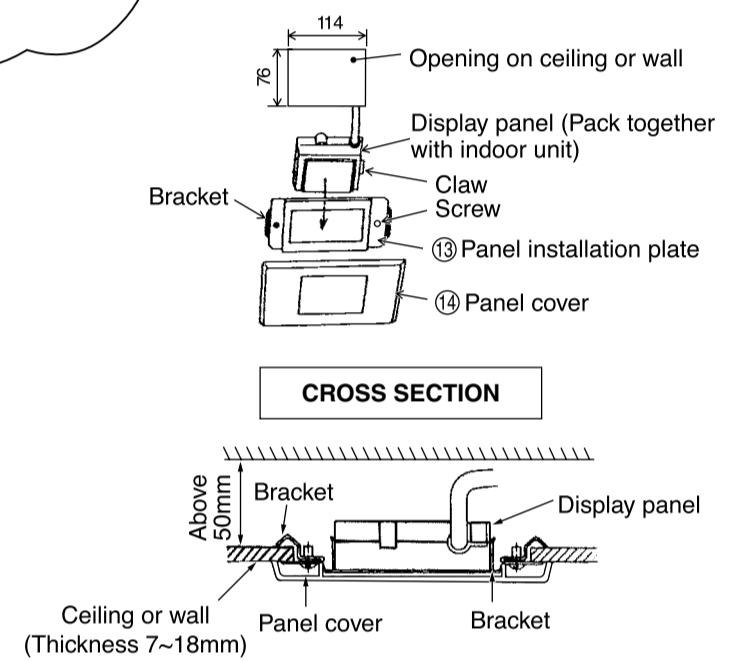

INSTALLATION OF SEMI DUCT TYPE

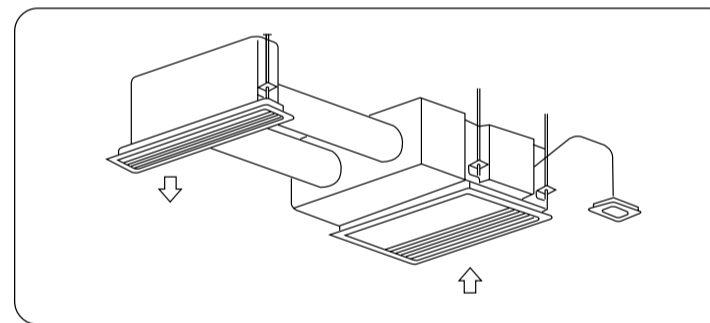

- Select the indoor unit position, fixing direction of air outlet so that cool/hot air reaches all the room. Standard position of the indoor unit is on wall side.

- Permissible length and bending of duct.

	Permissible length	Bending
Discharging side duct	4m or less	90° or less, 1 section

- Secure the space for installation, inspection or servicing.
- Apply waterproof treatment to back surface of ceiling under the indoor unit, to prevent water drop.
- Do not allow any obstacle to block air flow within 1m of suction grille.

(1) Installation figure

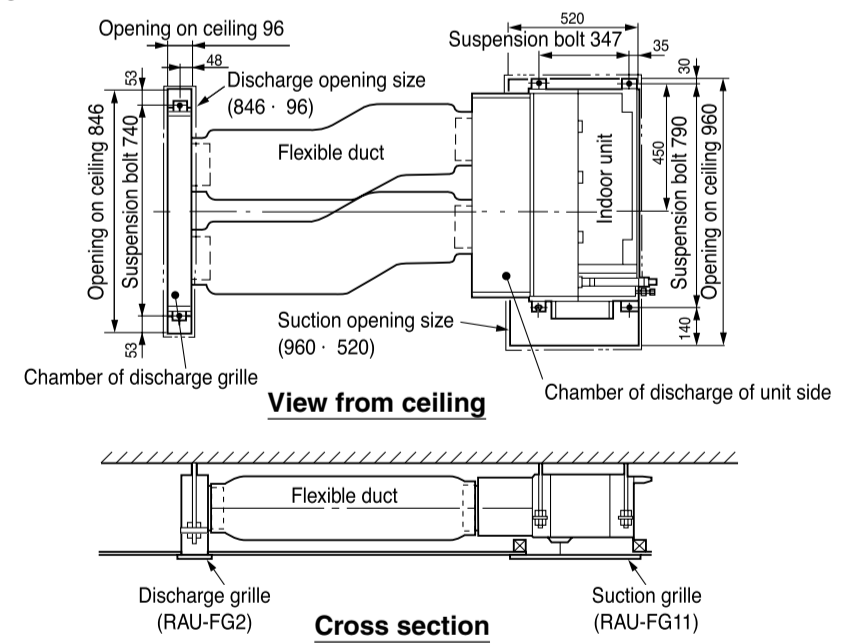

(Unit: mm)

(2) Opening on ceiling and suspension bolt position

• Indoor unit

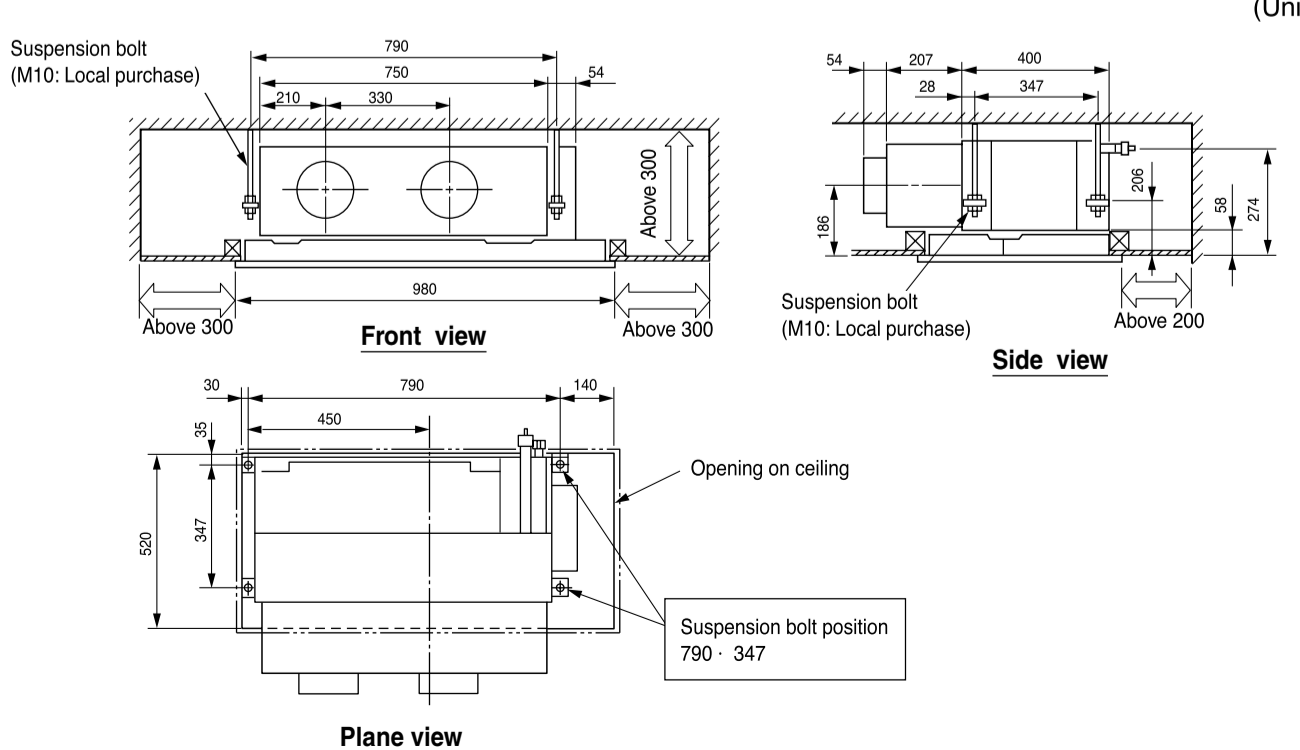

(Unit: mm)

(2) Chamber of discharge grille

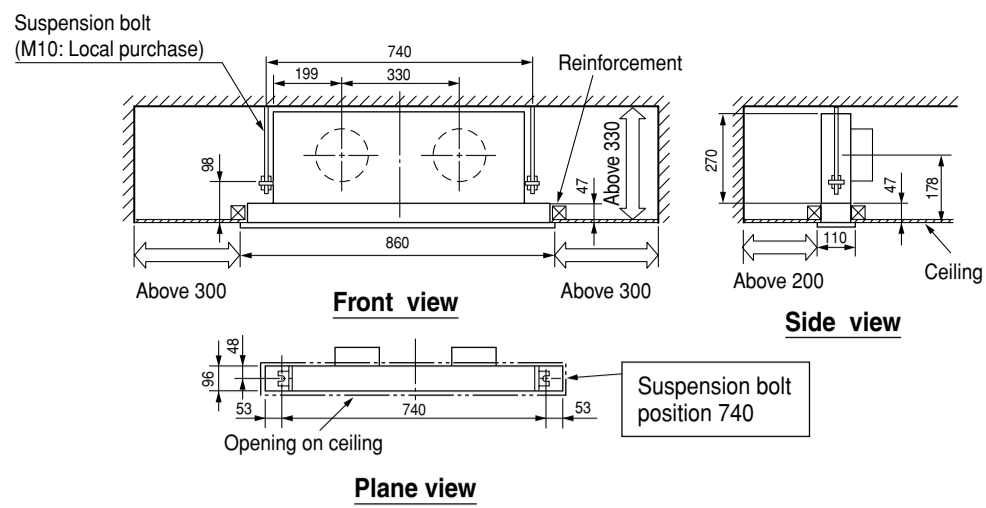

(3) Installation of suspension bolt

- This is the same as for discharge/suction duct type. Follow instructions for discharge/suction duct type.

(4) Preparation for installing indoor unit

- Remove 1 screw by which electric box is fixed, and then remove the electric box. Install the screw in the original position.
- Turn removed electric box with lead wires kept connected so that wire lead out section is positioned at the upper side, and hook the claw of electric box to side plate. Then fix the electric box to the bottom of the indoor unit using 1 screw.
- Install 4 suspension clamps at both sides of indoor unit, 2 clamps at each side, using 8 tapping screws. (Since sizes of left and right clamps are different for certain parts, refer to diagram on the right.)
- Chamber of discharge of unit side (optional part: RAU-DU2) on the indoor unit using 10 tapping screws.

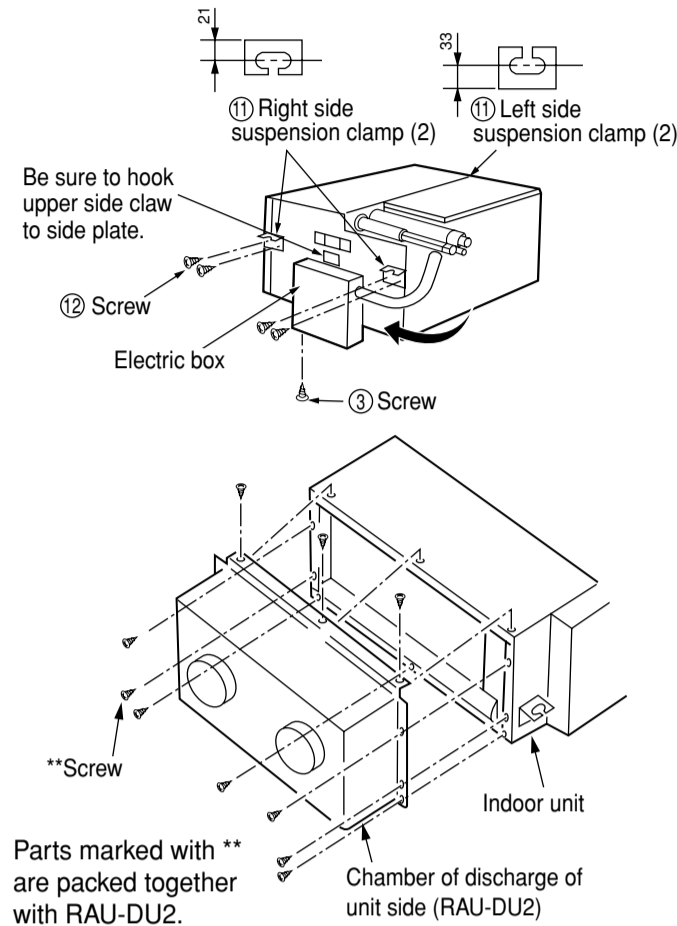

(5) Installation of indoor unit

- Set nut and washer on suspension bolt and hook it to suspension clamp by lifting the indoor unit.
- Make sure that indoor unit is kept level using a level or vinyl hose with water.
- Fix the indoor unit so that the space between bottom surfaces of ceiling and indoor unit is 58mm.

[Installation of chamber of discharge grille (RAU-GD2)]
 [Installation of suction grille (RAU-FG11)]
 [Installation of discharge grille (RAU-FG2)]
 [Installation of flexible duct (RAU-FD1, 2)]
 Refer to installation manual of optional part.

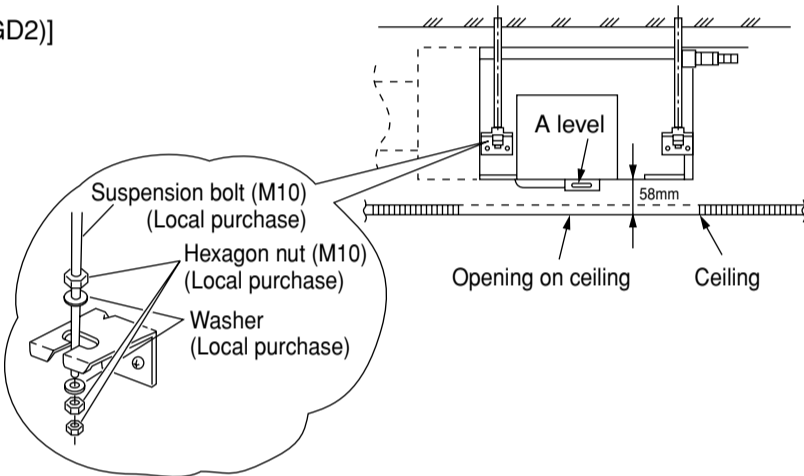

CAUTION

- Be sure to install the indoor unit level. If the indoor unit is inclined, water may leak.
- If space between bottom surfaces of indoor unit and ceiling is not correct, there may be a gap between grille and ceiling surface, with consequent dropping of condensed water.

(6) Installation of display panel

- Select an installation position on ceiling or wall where there is no obstacle to interrupt signal reception.
- Loosen screws of panel installation plate so that bracket can be slightly moved.
- Match the display panel to panel installation plate so the fixing claws on the panel are securely hooked.
- Match brackets to the opening on ceiling or wall and tighten screws until bracket is firmly secured to ceiling material.
- Install the panel cover so inside claws are securely hooked to the panel installation plate.
- Conduct the indoor unit side housing of display panel cord to the electric box of the indoor unit and connect it with the housing at the side of the unit.

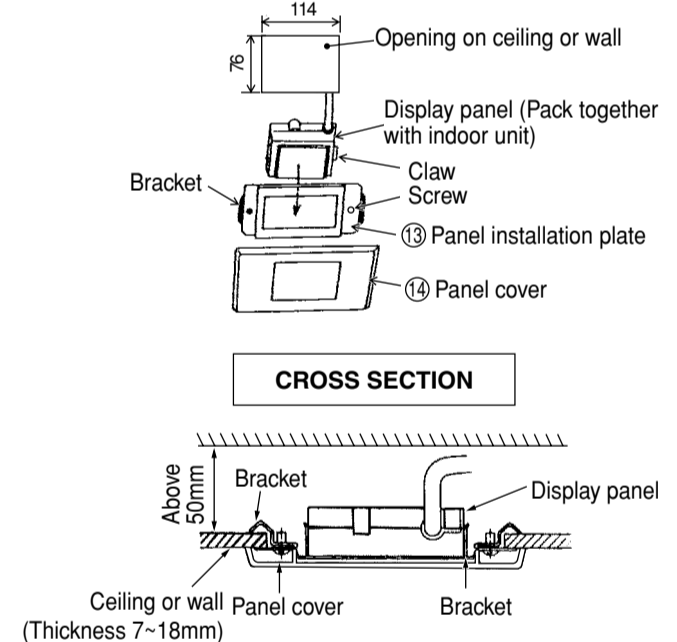

INSTALLATION OF NON DUCT TYPE

(1) Installation figure

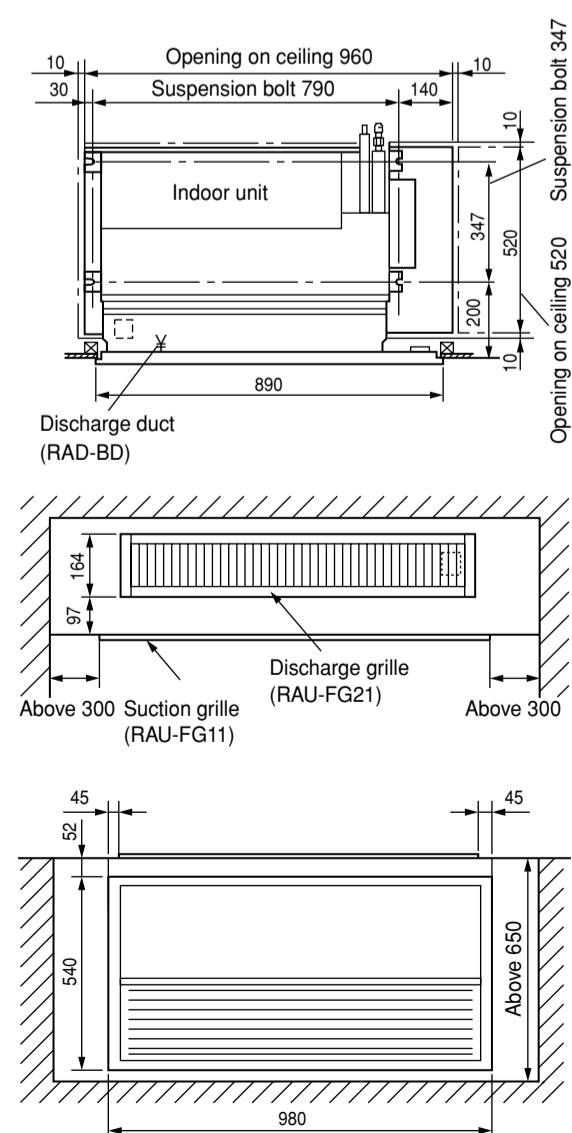

- Select the indoor unit position, fixing direction of air outlet so that cool/hot air reaches all the room.
- Do not allow any obstacle to block air flow within 1m of suction grille.

(Unit: mm)

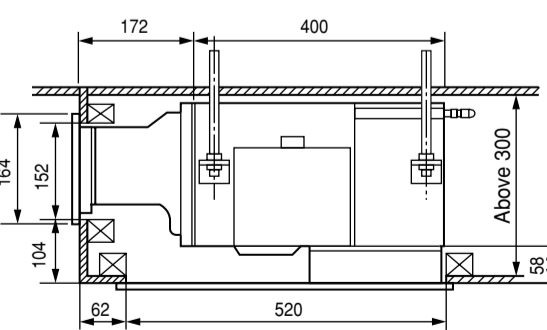
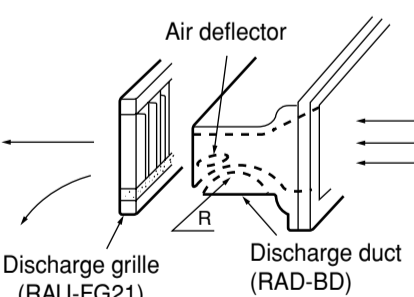

(2) Opening on ceiling and suspension bolt position

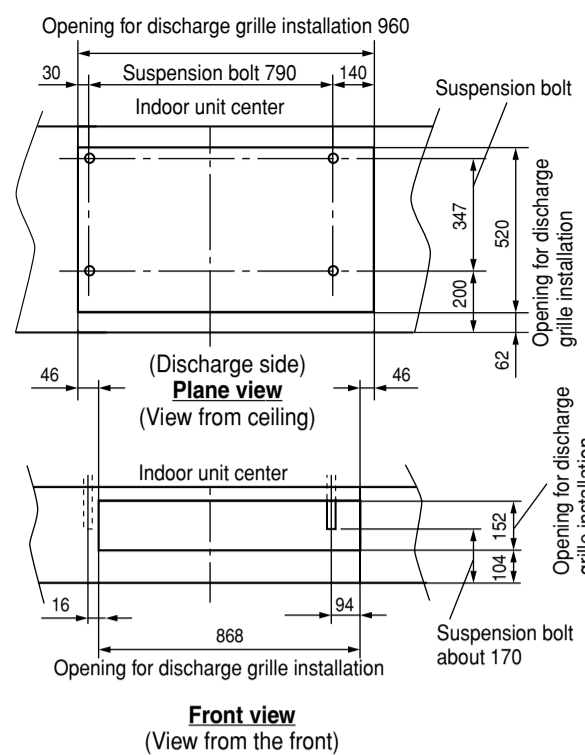

- Use M10 bolt for suspension bolt.
- Opening of ceiling and suspension bolt position are as shown on the left.
- Before installing the indoor unit, prepare opening 960mm · 520mm on ceiling, and 868mm · 152mm on wall and arrange drain pipe, refrigerant pipe and connecting cord in their installation positions.
- For finishing of opening on ceiling and wall, arrange with builder in detail.
- Be sure to reinforce furring of ceiling (frame: ceiling joist and joist supporter) to maintain level of ceiling and prevent vibration of ceiling plate.

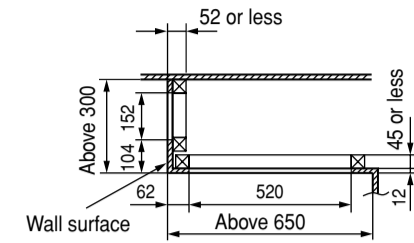

(3) Installation of suspension bolt

- This is the same as for discharge/suction duct type. Follow instructions for discharge/suction duct type.

(Unit: mm)

(4) Preparation for installing indoor unit

- Remove 1 screw by which electric box is fixed, and then remove the electric box.
- Turn removed electric box with lead wires kept connected so that wire lead out section is positioned at the upper side, and hook the claw of electric box to side plate. Then fix the electric box to the bottom of the indoor unit using 1 screw.
- Install 4 suspension clamps at both sides of indoor unit, 2 clamps at each side, using 8 tapping screws.
- Match discharge duct facing down (motor lead is set to left side) to discharge port of indoor unit and install using 6 tapping screws.

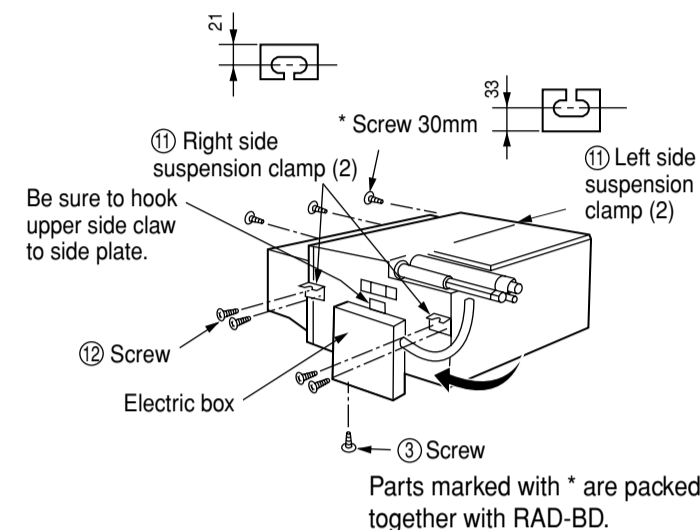

(5) Installation of grille clamp

- Install grille clamp on discharge port as shown below.

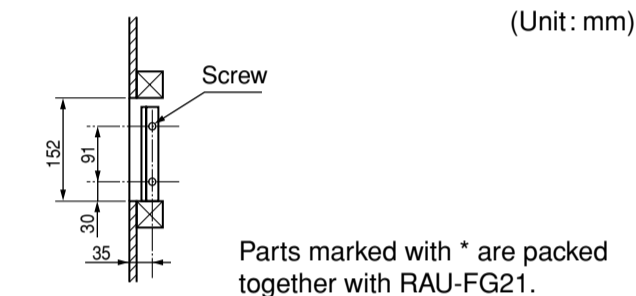
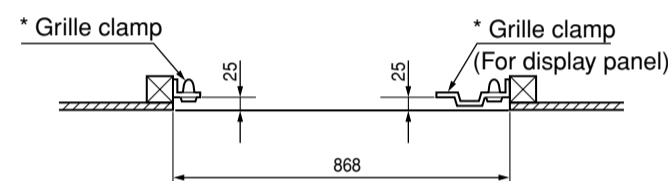

(Unit: mm)

(6) Installation of indoor unit

- Set nut and washer on suspension bolt and hook it to suspension clamp by lifting the indoor unit.
- Make sure that indoor unit is kept level using a level or vinyl hose with water.
- Fix the indoor unit so that the space between bottom surfaces of ceiling and indoor unit is 58mm.

CAUTION

- Be sure to install the indoor unit level. If the indoor unit is inclined, water may leak.
- If space between bottom surfaces of indoor unit and ceiling is not correct, there may be a gap between grille and ceiling surface, with consequent dropping of condensed water.

(7) Installation of display panel

- As shown on the right, install the display panel so that claw of the panel securely hooks to the grille clamp (for display panel).

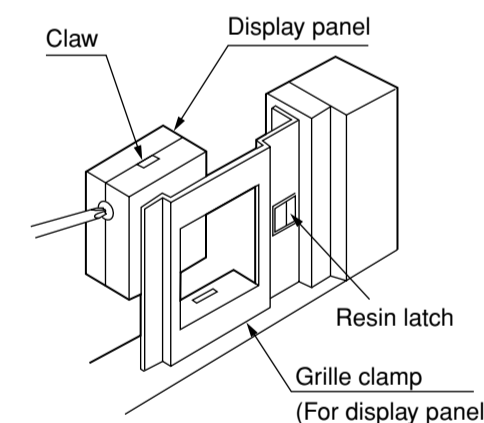

(8) Installation of discharge grille

- Install after making sure that resin latch securely fits into grille.

(9) Installation of suction grille

- Refer to the installation manual of the suction grille (RAU-FG11).

2.5 Connection of drain pipe

- Securely glue connection part of drain hose and PVC pipe, using PVC adhesive.

CAUTION

- If gluing of drain hose and PVC pipe is too weak, water leakage may occur.

- Be sure to wrap generally-available insulator (10mm or more of foamed polythylene) around drain hose, inside the house, for insulation heat.
- Checking drain and water leakage. Perform after connecting power.
 - Refer to discharge grille of indoor unit.
 - Add water to water pan of indoor unit as shown below.
- Test run method
 - Turn power on.
 - Remove lid of electric box and set the drain pump test run switch to TEST RUN.
 - After checking the drainage, return the switch to NORMAL.
- Perform test running of drain pump to check drainage operation.

CAUTION

- If checking of drainage is omitted, water drop may occur.
- If drain pump test run is left set to TEST RUN, drain pump may malfunction.

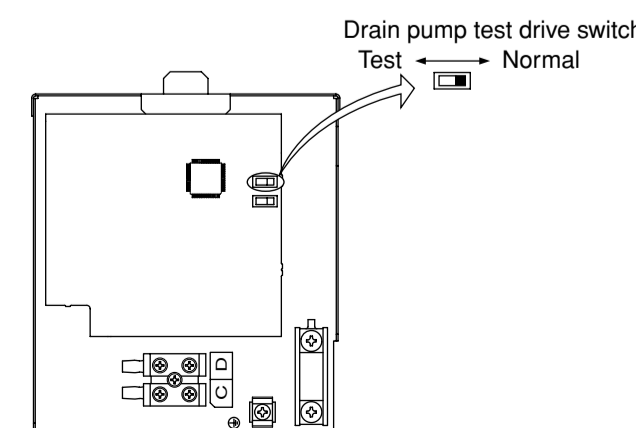
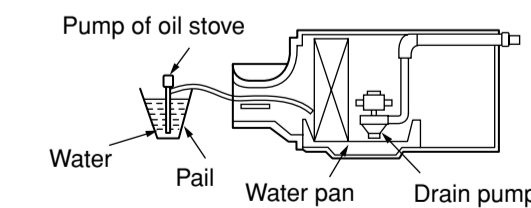
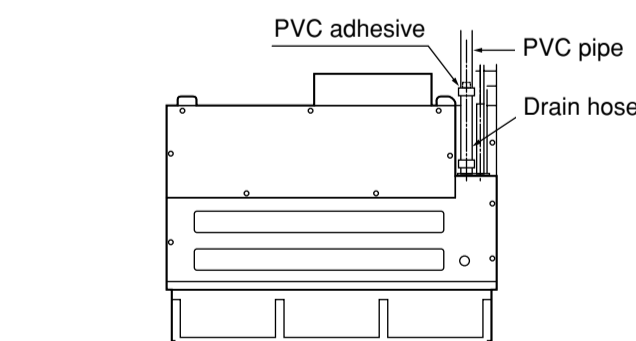

2.6 Preparation of pipe

- Use a pipe cutter to cut the copper pipe.

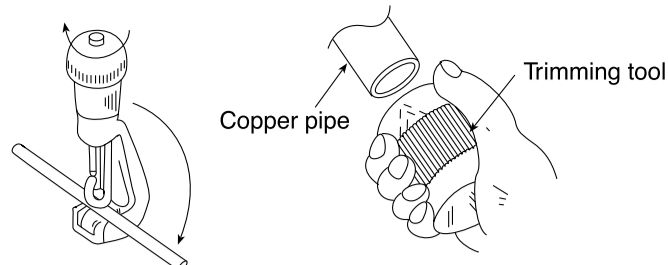

CAUTION

- Jagged edge will cause leakage.
- Point the side to be trimmed downwards during trimming to prevent copper chips from entering the pipe.

- Before flaring, please put on the flare nut.

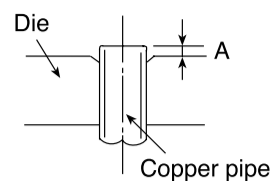
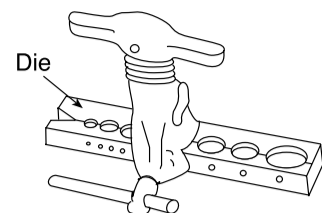

- Please use exclusive tool.

Outer Diameter (φ)	A (mm) Rigid Flaring Tool	
	For R410A tool	For R22 tool
6.35 (1/4")	0 - 0.5	1.0
9.52 (3/8")	0 - 0.5	1.0
12.7 (1/2")	0 - 0.5	1.0

2.7 Pipe connection

CAUTION

In case of removing flare nut of an indoor unit, first remove a nut of small diameter side, or a seal cap of big diameter side will fly out. Free from water into the piping when working.

- Please be careful when bending the copper pipe.
- Screw in manually while adjusting the center. After that, use a torque wrench to tighten the connection.

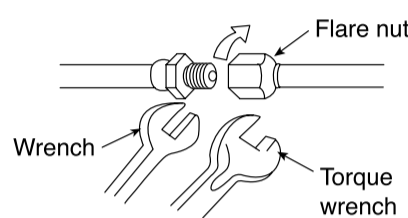

		Outer diameter of pipe (φ)	Torque N·m (kgf·cm)
Small diameter side		6.35 (1/4")	13.7 - 18.6 (140 - 190)
		9.52 (3/8")	34.3 - 44.1 (350 - 450)
Large diameter side		12.7 (1/2")	44.1 - 53.9 (450 - 550)
Valve head cap	Small diameter side	6.35 (1/4")	19.6 - 24.5 (200 - 250)
	Large diameter side	9.52 (3/8")	19.6 - 24.5 (200 - 250)
		12.7 (1/2")	29.4 - 34.3 (300 - 350)
Valve core cap			12.3 - 15.7 (125 - 160)

Gas leakage inspection

Please use gas leakage detector to check if leakage occurs at connection of flare nut as shown on the right.

If gas leakage occurs, further tighten the connection to stop leakage. (Use the detector provided for R410A.)

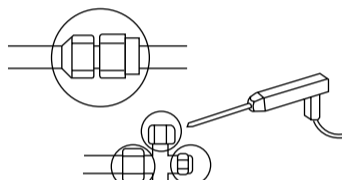

Sealing the refrigerating pipe

Cover pipe connection section using flare insulation material and wrap tape around it with no gap.

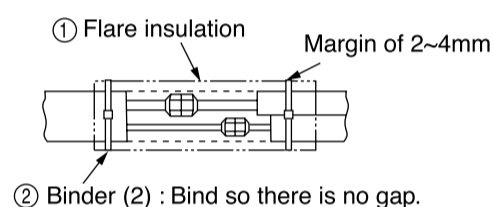

2.8 Connection of the connecting cord

- Remove the cover of the electric box.
- Connect the connecting cords.
- Assemble the cover of electric box.

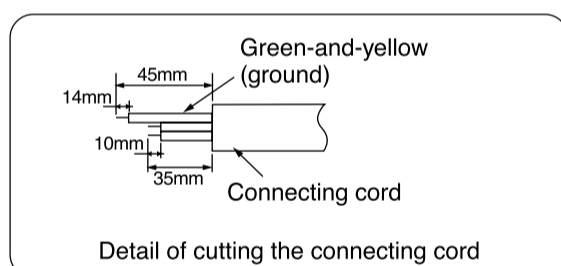

WARNING

- THIS APPLIANCE MUST BE EARTHED.

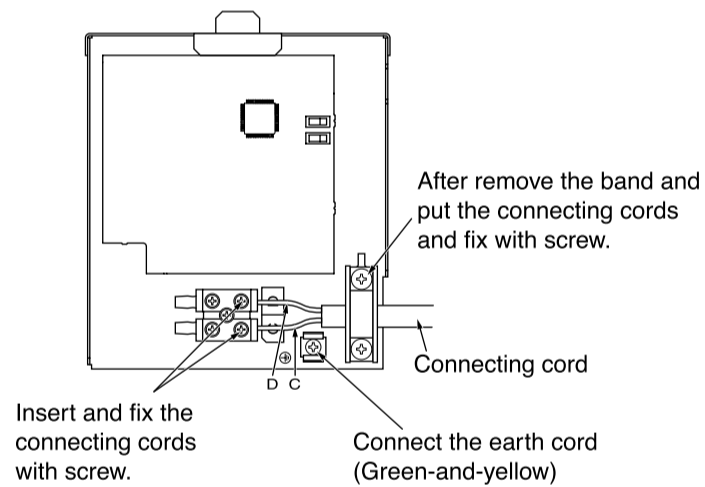

3. Checking of drawing drain hose

- Connect the separate drain hose to the drain hose that is attached to the indoor unit.
- For keeping the smooth flowing of condensed water the drain hose should be inclined as shown in figure below.

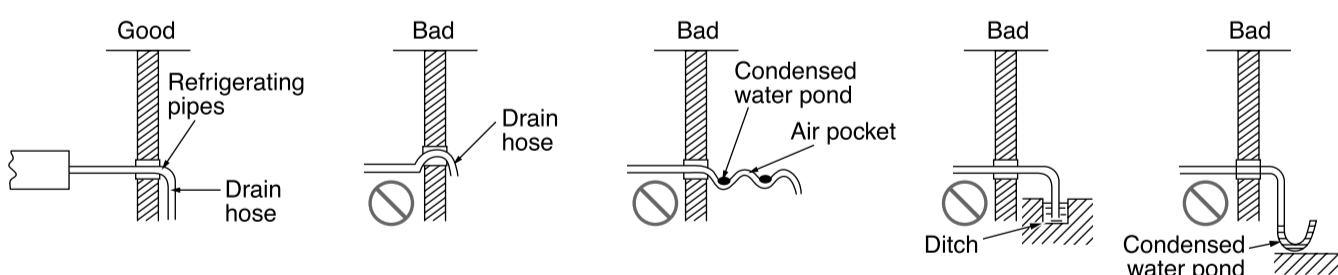

CAUTION

Please ensure the smooth flow of condensed water of the indoor unit during installation. (Carelessness may result in water leakage.)

CAUTION

Be sure that the hose is not loosely connected or bent.

4. Installation of remote controller

- The remote controller can be placed in its holder which is fixed on wall or beam.
- To operate the remote controller at its holder, please ensure that the unit can receive signal transmitted from the controller at the place where the holder is to be fixed. The unit will beep when signal is received from the remote controller. The signal transmission is weakened by the fluorescent light. Therefore, during the installation of the remote control holder, please switch on the light, even during day time, to determine the mounting location of the holder.

The controller must be hooked onto the hook at the lower part of the holder. Push in the remote controller in the direction as shown in figure below.

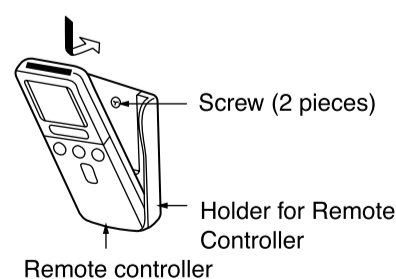

5. Checking procedure after installation

- Confirm the smooth water flowing from the drain hose by pouring some water into the evaporator pan.
- Arrange the penetrating part of the wall presentably with the bushing for refrigerating pipes and sealer which is belonging to the pipe set as shown in Figs. 5-1, 5-2 and 5-3.

Wall penetration and installation of protection pipe

- Drill a ø65mm hole on wall which is slightly tilted towards the outdoor side. Drill the wall at a small angle.
- Cut the protection pipe according to the wall thickness.
- Empty gap in the sleeve of protection pipe should be completely sealed with putty to avoid dripping of rain water into the room.

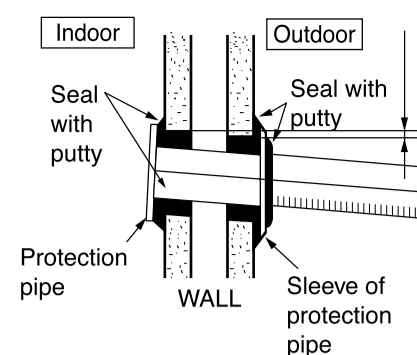

CAUTION

Be sure that the wire is not in contact with any metal in the wall. Please use the protection pipe as wire passing through the hollow part of the wall so as to prevent the possibility of damaged by mouse.

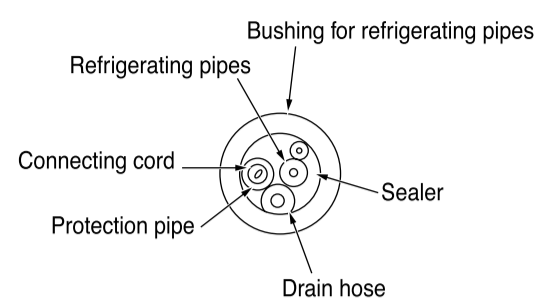

Fig. 5-3

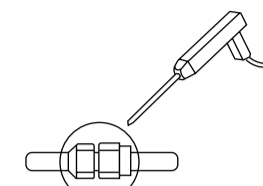

Fig. 5-4

- Wind the inadhensive vinyl tape which is belonged to the pipe set round the refrigerating pipes and the connecting cord.

- Leakage checking of refrigerant at the coupling by gas leak detector or soapsuds, as shown in Fig. 5-4.

- Checking of evaporator coldness (cooling operation).

- Checking of warm wind from condenser (cooling operation).

6. Setting of switches

(1) High static-pressure switch

(Full duct type and semi duct type)

- For full duct type and semi duct type, set the high static-pressure switch to HIGH STATIC-PRESSURE.
- If not set to HIGH STATIC-PRESSURE, there will be reduction of cooling and heating capacities. (At the time of delivery, the switch is set as iNORMAL.)

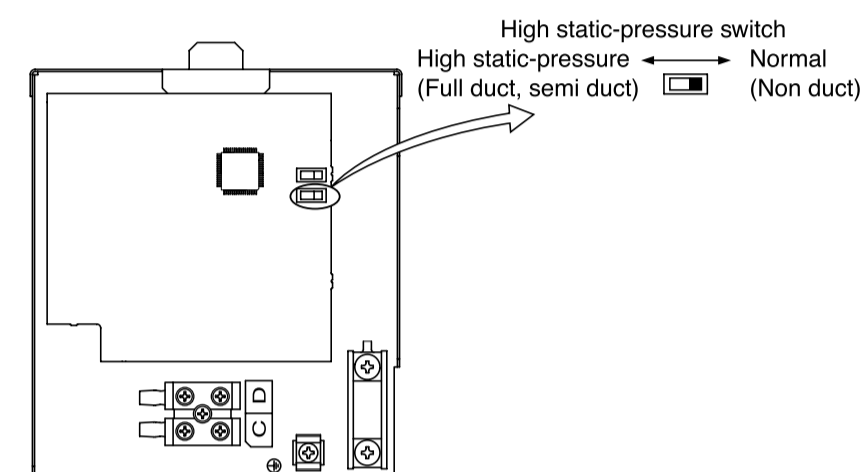

7. Connection of discharge duct and display panel lead wires

- Connect the motor connector of discharge duct to the connector at the side (see diagram on the right).
- Attach the connector of this panel to the connector on the control PWB.
- Be sure to fix the motor lead wire of discharge duct using fixing band. (For full duct type and semi duct type connect only display panel.)

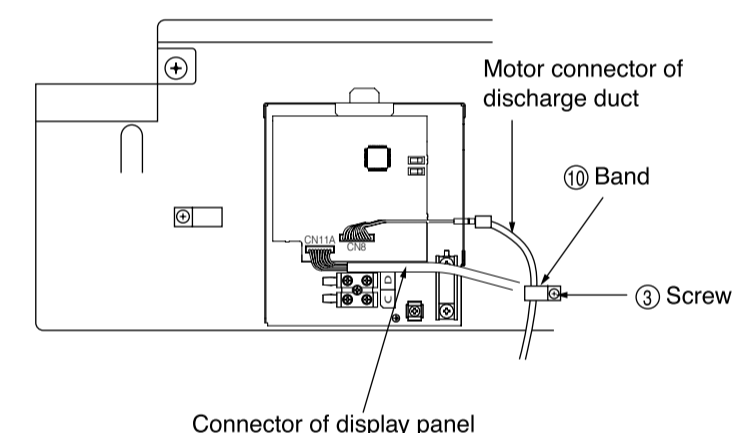

8. Protection of lead wire

Wrap aluminum tape around PVC tube between electric box and indoor unit (cord band).

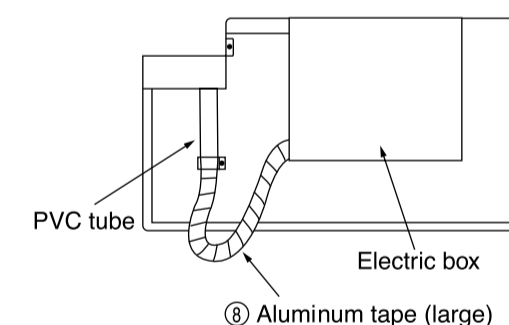

9. Operation test

- Please ensure that the air conditioner is in normal operating condition during the operation test.
- Explain to your customer the proper operation procedures as described in the user's manual.
- If the indoor unit does not operate, check to see that the connections are correct.

CAUTION

Trial run should be conducted on one unit at a time to check for incorrect wiring of connecting cord.