

FOR SERVICE PERSONNEL ONLY

HITACHI INVERTER SYSTEM MULTI TYPE OUTDOOR UNIT INSTALLATION MANUAL

MODEL **RAM-80QHS**

- Carefully read through the procedures of proper installation before starting installation work.
- The sales agent should inform customers regarding the correct operation of installation.
- Explanation for indoor unit is in the "How To Use" (Instruction Manual) that packed with indoor unit.

Tools Needed For Installation Work (Mark ① is exclusive use tool for RA10A)
 ① Screwdriver • Measuring Tape • Knife • Saw • 65mm Power Drill • Hexagonal Wrench
 Key (3/4mm) • Wrench (14, 17, 22, 26, 27mm) ② Gas Leakage Detector • Pipe Cutter • Putty
 • Vinyl Tape • Pliers • Flare Tool ③ Vacuum Pump Adapter ④ Manifold Valve ⑤ Change Hose
 ⑥ Vacuum Pump

SAFETY PRECAUTION

- Read the safety precautions carefully before operating the unit.
 - The contents of this section are vital to ensure safety. Please pay special attention to the following sign.
 - **WARNING** Incorrect methods of installation may cause death or serious injury.
 - **CAUTION** Improper installation may result in serious consequence.
 - **Make sure to connect earth line.**
 - **This sign in the figures indicates prohibition.**
- Be sure that the unit operates in proper condition after installation. Explain to customer the proper way of operating the unit as described in the user's guide.

WARNING

- Please request your sales agent or qualified technician to install your unit. Water leakage, short circuit or fire may occur if you do the installation work yourself.
- Please observe the instructions stated in the installation manual during the process of installation. Improper installation may cause water leakage, electric shock and fire.
- Make sure that the units are mounted at locations which are able to provide full support to the weight of the units. If not, the units may collapse and impose danger.
- Observe the rules and regulations of the electrical installation and the methods described in the installation manual when dealing with the electrical work. Use wire which are approved official in your country. A short circuit and fire may occur due to the use of low quality wire or improper work.
- Be sure to use the specified wire for connecting the indoor and outdoor units. Please ensure that the connections are tight after the conductors of the wire are inserted into the terminals. Improper insertion and loose contact may cause over-heating and fire.
- Please use the specified components for installation work. Otherwise, the unit may collapse or water leakage, electric shock and fire may occur.
- When installing or transferring an air conditioner to another location, make sure that air other than the specified refrigerant (RA10A) does not enter the refrigeration cycle. If other air should enter, the pressure level of the refrigerant cycle may increase abnormally which could result in a rupture and injury.
- Be sure to use the specified piping set for RA10A. Otherwise, this may result in broken copper pipes or faults.
- When installing or removing an air conditioner, do not allow air or moisture to remain in the refrigeration cycle. Otherwise, pressure in the refrigeration cycle may become abnormally high so that a rupture may be caused.
- Be sure to conduct the earth line from the power supply wire to the outdoor unit and between the outdoor and indoor unit. Improper earthing may cause electric shock.

CAUTION

- A circuit breaker must be installed in the house distribution box for the direct connected power supply wire to the outdoor unit. In case of other installations a main switch with a contact gap or more than 3mm has to be installed. Without a circuit breaker, the danger of electric shock exists.
- Do not install the unit near a location where there is flammable gas. The outdoor unit may catch fire if flammable gas leaks around it. Piping shall be suitable supported with a maximum spacing of 1m between the supports.
- Please ensure smooth flow of water when installing the drain hose.
- An IEC approved power cord should be used. Power cord type : NVM.

Accessories to Outdoor unit:

No.	Item	Quantity
①	Drain pipe	1
②	Bushing	1

THE CHOICE OF MOUNTING SITE

(Please note the following matters and obtain permission from customer before installation.)

WARNING

- The outdoor unit must be mounted at a location which can support heavy weight. Otherwise, noise and vibration will increase.

CAUTION

- Do not expose the unit under direct sunshine or rain. Besides, ventilation must be good and clear of obstruction.
- The air blown out of the unit should not point directly to animals or plants.
- The clearance of the unit from top, left, right and front are specified in figure below. At least two of the above sides must be open air. If it is possible to open only two sides, make sure the discharging side is one of them.
- Be sure that the hot air blown out of the unit and noise do not disturb the neighbourhood.
- Do not install at a location where there is flammable gas, steam, oil and smoke.
- The location must be convenient for water drainage.
- Place the outdoor unit and its connection wire at least 1m away from the antenna or signal line of television, radio or telephone. This is to avoid noise interference.

Height difference

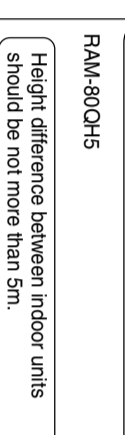

Piping length

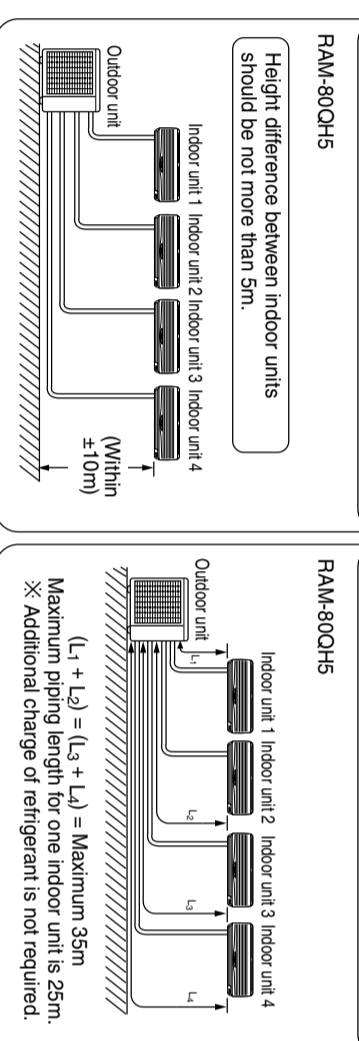

Outdoor unit installation

- The pipe connection ports of the outdoor unit and connectable indoor units are shown below. (Connection of the compressors is as shown below.)

RAM-80QHS

- To the outdoor unit, up to four indoor units can be connected until the total value of each unit's capacity reaches 12.0kW. However, install indoor units so that total capacity of indoor unit 1 and indoor unit 2 and total capacity of indoor unit 3 and indoor unit 4 are approached. For example, when two 2.5kW units and two 3.5kW units are to be connected, connect as shown below.
- Connect 3 or more indoor units. (Only two units are to be connected, connect them as indoor unit 1 and indoor unit 2 or indoor unit 3 and indoor unit 4. However, when two 3.5kW units are connected or when one 2.5kW unit and one 3.5kW unit are connected, capacity may be less than indicated capacity.)

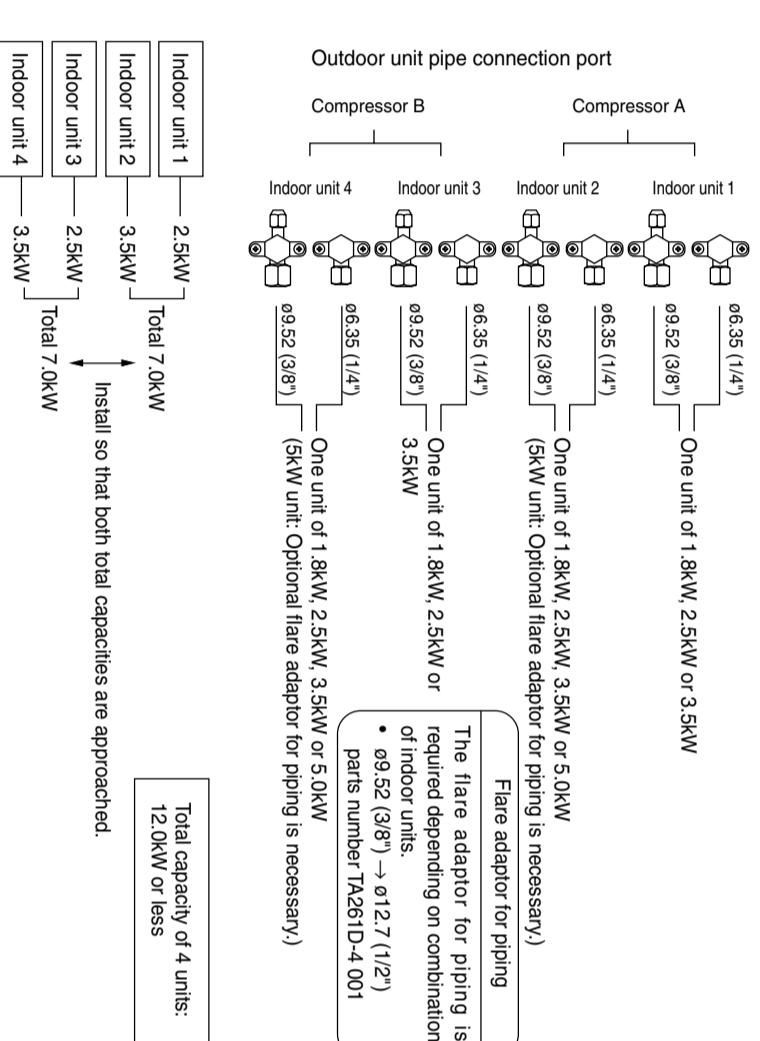

NAMES OF EACH PART AND DIMENSIONS

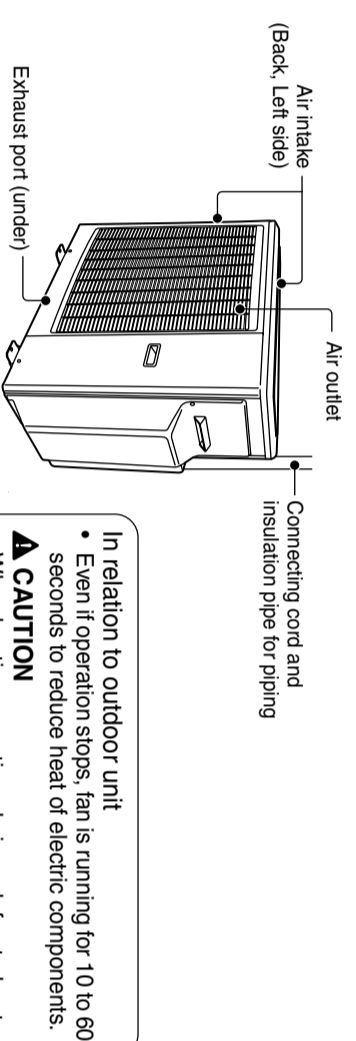

- In relation to outdoor unit even if operation stops, fan is running for 10 to 60 seconds to reduce heat of electric components.
- **CAUTION** When heating operation, drain or defrosted water flows out from outdoor unit. Don't stop up drain outlet portion in chilly area so as not to freeze these.

MODEL	WIDTH	HEIGHT	DEPTH
RAM-80QHS	850mm (32-1/2")	830mm (32-11/16")	340mm (13-3/8")

- Remove electric box cover and three cord bands. Then, remove side panel and front panel in sequence. (If side panel cannot be removed at this time, remove top cover.)

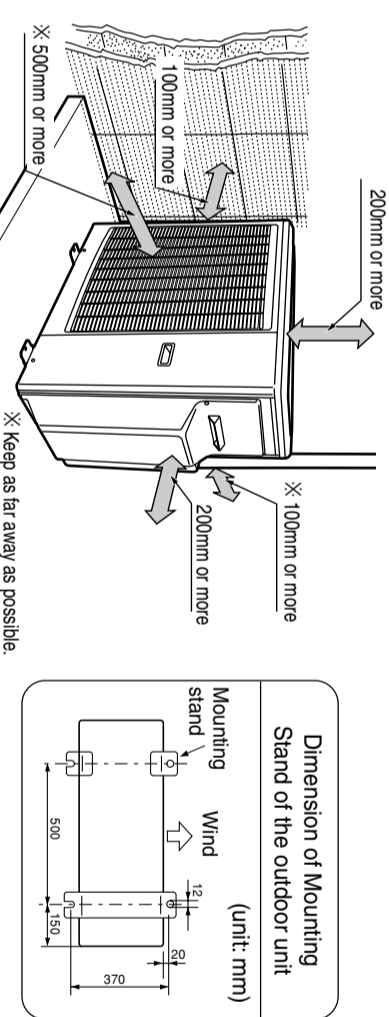

Condensed Water Disposal of Unit

- There is a hole on the base of outdoor unit for condensed water to exhaust.
- In order for condensed water to flow to the draining part, install the unit on the level ground or block so that the unit is 100mm above the ground same as figure shown. Join the drain pipe to one hole and cover the rest with bushing. If there are other holes or gaps, cover them with putty to prevent water from leaking out.
- At first insert one portion of the hook to the base, then pull the drain pipe in the direction shown by the arrow while inserting the hook into the base. After installation, check whether the drain pipe clinging to the base firmly.

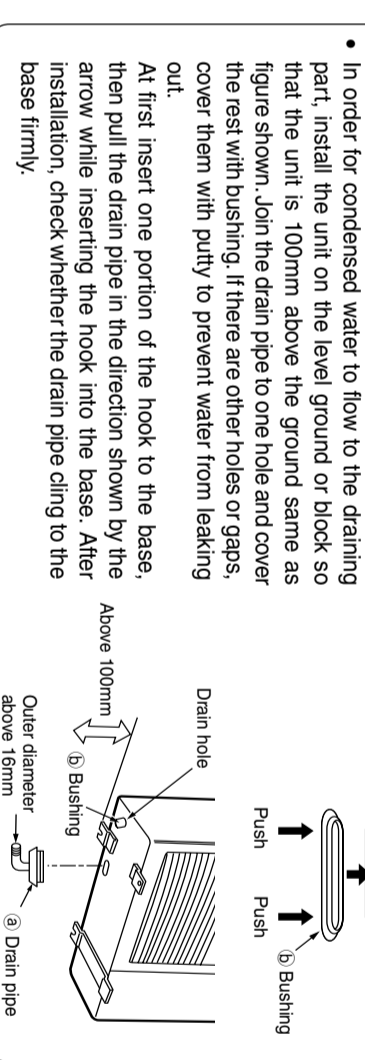

If you wish to prepare the copper tubes and insulation material in the field, we recommend the following:

No.	Material	Specification
1	Copper tube	Small dia. Deoxidized annealed copper pipe with 6.35mm O.D., 0.8mm wall thickness. Large dia. Deoxidized annealed copper pipe with 9.52mm O.D., 1.0mm wall thickness. Small dia. Deoxidized annealed copper pipe with 6.35mm O.D., 0.8mm wall thickness. Large dia. Deoxidized annealed copper pipe with 12.7mm O.D., 1.0mm wall thickness.
2	Flare nut	Small dia. Flare nuts with 6.35mm O.D. Large dia. Flare nuts with 9.52mm O.D. Small dia. Flare nuts with 6.35mm O.D. Large dia. Flare nuts with 12.7mm O.D.
3	Insulation for refrigerating pipe	Foamed polyethylene insulation pipe which does not corrode the copper tube. Large dia. pipe size: 15mm I.D., 8mm wall thickness. Small dia. pipe size: 8mm I.D., 7mm wall thickness.
4	Copper wire	Refer to item 2.1.
5	Vinyl tape	
6	Sealer (Putty)	
7	Refrigerator oil	
8	Bushing for refrigerating pipes	

1. Proper place for installation

- 1.1 Outdoor unit**
 - (1) Keep the space around the unit for maintenance and avoiding the effects of hindrance for normal ventilation of the unit.
 - (2) The northern or eastern side of the building is better to install. At the installation on the southern or western side unobstructed, some blind should be set up for the unit. (In this case, the blind must not obstruct the ventilation of the unit.)
 - (3) You'd better not put the unit at a place where is full of dirt and at a place where is wet in the rain.
 - (4) Place as near as possible to the indoor unit.

2. Checking of the power source and the voltage range

- 2.1** Before installation, the power source must be checked and necessary wiring work must be completed. To make the wiring capacity proper, use the wire gauges list below for the lead-in from a pole transformer and for the wiring from a switch board of fuse box to the outlet in consideration of the locked rotor current.

IMPORTANT	
Wire length	Wire gauge
Up to 25m	4.0mm ²

2.2 Investigate the power supply capacity and other electrical conditions at the installation location.

- Depending on the model of room air conditioner to be installed, request the customer to make arrangements for the necessary electrical work etc. The electrical work includes the wiring work up the outlet.

- 2.3** In localities where electrical conditions are poor, use of a voltage regulation is recommended. In the electrical installation a separator with a contact gap of more than 3mm has to be installed. During cleaning or service the set has to be switched off with this separator.

3. Installation procedure and notice

- Especially, the selection of installation place need great care for the split type air conditioner, because it is very difficult to move from place to place after the first installation.

3.1 Wiring

- (1) Connect the electrical wiring between the Indoor and Outdoor unit, as shown in Fig. 3-1. Never connect the wiring by mistake.
- (2) The connecting cord must be fixed by the band which is located near the terminal board.

WARNING • THIS APPLIANCE MUST BE EARTHED.

Important: The wires in this main lead are coloured in accordance with the following code:

CAUTION

- Since power is supplied through outdoor unit, do not connect power source to indoor unit.

Wiring Pattern

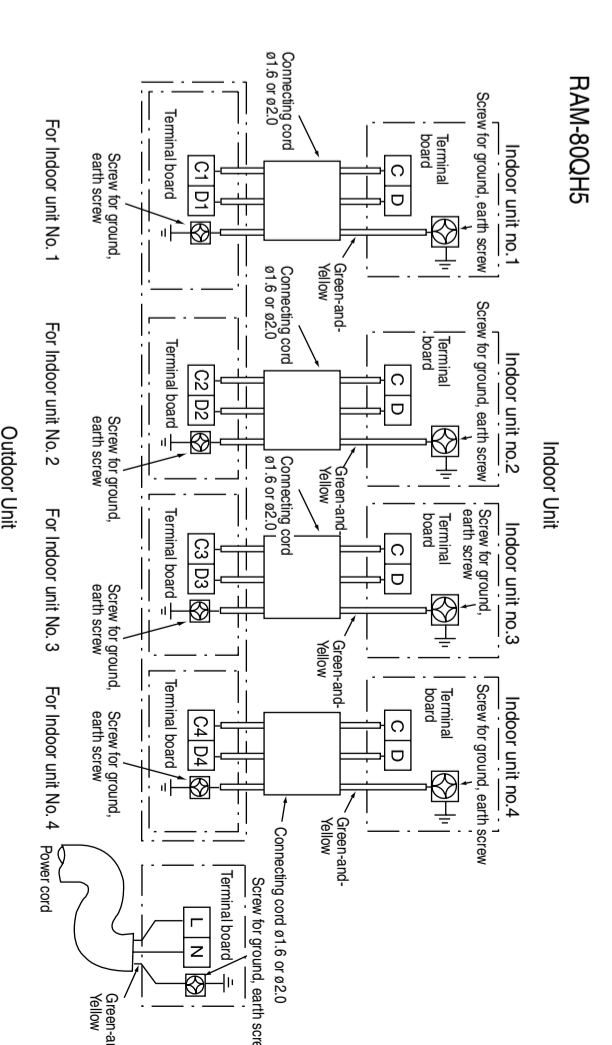

Fig. 3-1

- Please remove the side plate for wire connection.

- If you cannot attach the side plate due to the connecting cord, please press the connecting cord in direction to the front panel to fix it.

- Be sure that the hooks of the side plate is fixed in certainly. Otherwise water leakage may occur and this causes short circuit or faults.
- The connecting cord should not touch the service valve and pipes. (It becomes high temperature in heating operation.)

WARNING

3.2 Connection of the connecting cords and power cord

- (1) Cut off the connecting cord, the power cord and strip the insulation of the wire, as shown in Fig. 3-2.
- (2) Connect the connecting cord and power cord to the terminal board. (Fig. 3-3)
- (3) Fix the connecting cords and power cord with steel band certainly. (Fig. 3-3)

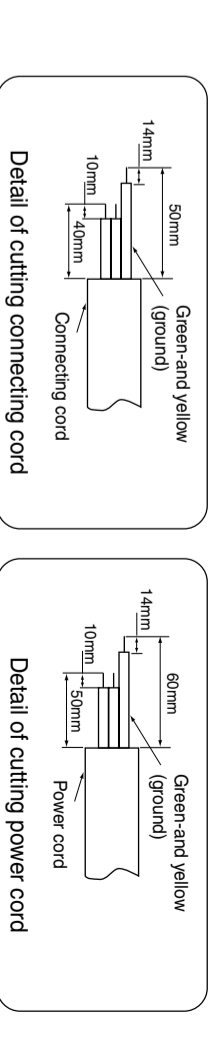

Fig. 3-2

WARNING

- The naked part of the wire core should be 10mm and fix it to the terminal tightly. Then try to pull the individual wire to check if the contact is tight. Improper insertion may burn the terminal.
- Be sure to use only wire specified for the use of air conditioner.
- Please refer to the installation manual for wire connection and the wiring technique should meet the standards of electrical installation.
- There is an AC voltage drop between the LN terminals if the power is on. Therefore, be sure to switch off the power supply.

WARNING

- Connecting cord should be connected according to Fig. 3-1, that the indoor unit No. agree with terminal board No. of Outdoor unit.
- Be sure to fix the connecting cord with the band as shown below. Otherwise water leakage causes short circuit or faults.

- Below figure shows a case of RAM-80QHS.

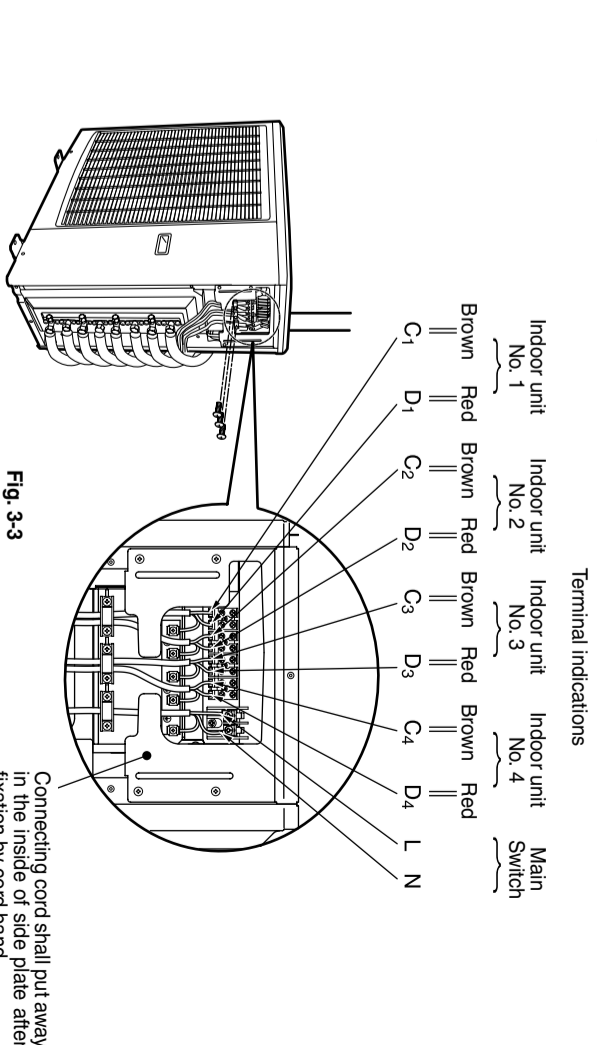
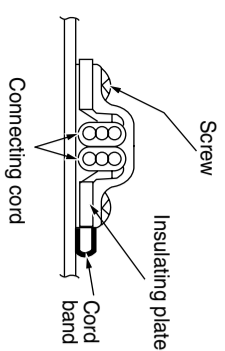

Fig. 3-3

Connecting cord shall put away in the inside of side plate after fixation by cord band.

- When putting 2 connecting cords through the band.



- Leave some space in the connecting cord for maintenance purpose and be sure to secure it with the cord band.
- Secure the connecting cord along the coated part of the wire using the cord band. Do not exert pressure on the wire as this may cause overheating or fire.

WARNING

- Jagged edge will cause leakage.
- Point the side to be trimmed downwards during trimming to prevent copper chips from entering the pipe.

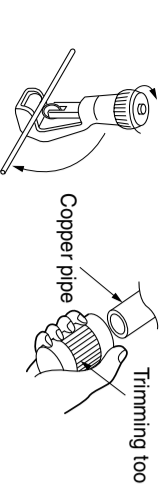

- Before flaring, please put on the flare nut.

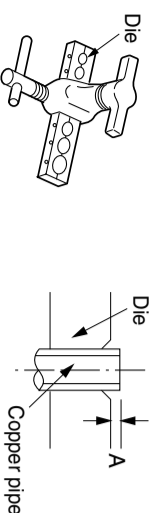

- Please use exclusive tool.

Outer Diameter (φ)	A (mm) Rigid Flaring tool	
	For R410A tool	For R22 tool
6.35 (1/4")	0 - 0.5	1.0
9.52 (3/8")	0 - 0.5	1.0
12.7 (1/2")	0 - 0.5	1.0

3.4 Pipe connection

- Connecting the pipe to outdoor unit**
- Remove the flare nut and seal cap from the service valve.
 - Apply refrigerant oil to the service valve and the flared portion of the pipe.
 - Using a wrench, securely tighten.

Tighten all the way by hand.

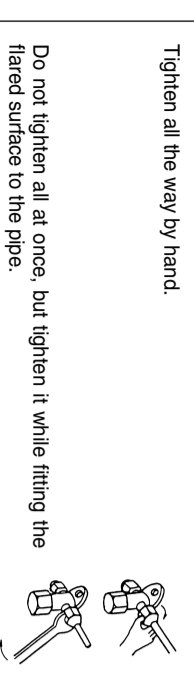
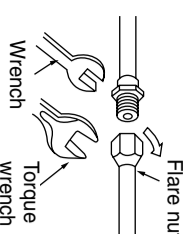

Fig. 3-4

CAUTION In case of removing flare nut of an indoor unit, first remove a nut of small diameter side, or a seal cap of large diameter side will fly out. Free from water into the piping when working.

- Please be careful when bending the copper pipe.
- Screw in manually while adjusting the center. After that, use a torque wrench to tighten the connection.



Flare nut	Outer diameter of pipe (φ)	Torque N·m (kgf·cm)
Small diameter side	6.35 (1/4")	13.7-18.6 (140-190)
	9.52 (3/8")	34.3-44.1 (350-450)
Large diameter side	12.7 (1/2")	44.1-53.9 (450-550)
	6.35 (1/4")	19.6-24.5 (200-250)
Valve head cap	9.52 (3/8")	19.6-24.5 (200-250)
	12.7 (1/2")	29.4-34.3 (300-350)
Valve core cap		12.3-15.7 (125-160)

- Install the unit in a stable place to minimize vibration or noise.
- After arranging the cords and pipes, secure them in place.

RAM-80QHS

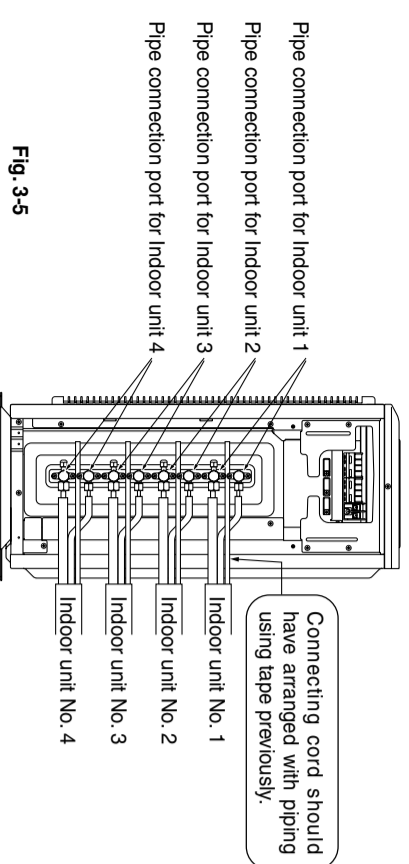

Fig. 3-5

- Hold the handle of the side cover, slide down and take off the corner hook, then pull. Reverse these steps when installing.

4. Air purging

After completing the piping, purge the air from the connected pipe and indoor unit. If this work is not done, the discharge pressure will abnormally rise so that the refrigerating cycle unit will possible be damaged or inoperative.

4.1 Air purging by using vacuum pump

Remove the valve cap of valve core.

Connect the charge hoses to the vacuum pump and the charge port of the valve core large dia. pipe side service valve, respectively.

Fully open the LO knob of the manifold valve.

Put the vacuum pump into run.

Close the LO knob of the manifold valve.

Stop the vacuum pump.

Remove the valve cap from the spindle of the service valve.

Turn the spindles of each large and small dia. pipe side service valves full counterclockwise until they are securely tightened. Then retighten them more than 10 degrees (using a hexagon wrench key (4mm (φ) without fail).

Disconnect the charge hose from the service valve.

Tighten the valve cap of valve core. [Torque 12.3-15.7 N·m (125-160 kgf·cm)]

Attach the valve cap to the spindles of each large and small dia. pipe side service valves.

Tighten the valve cap of the spindle. [Torque 19.6-24.5 N·m (200-250 kgf·cm)]

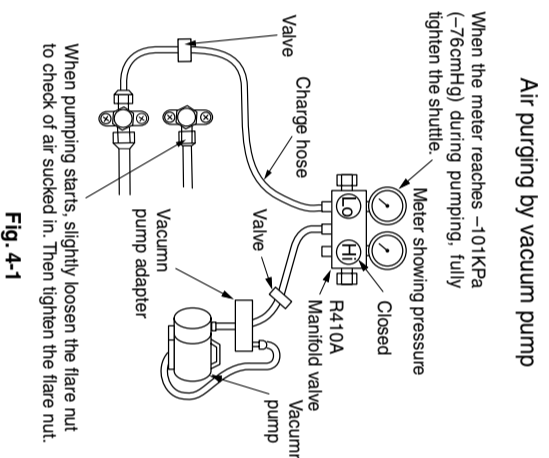

Fig. 4-1

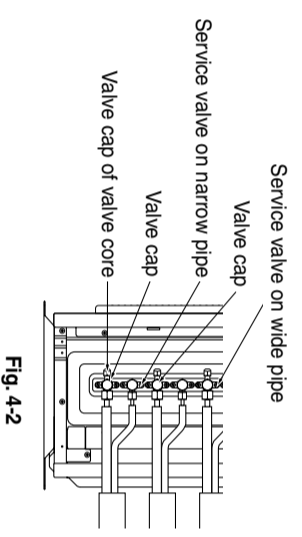

Fig. 4-2

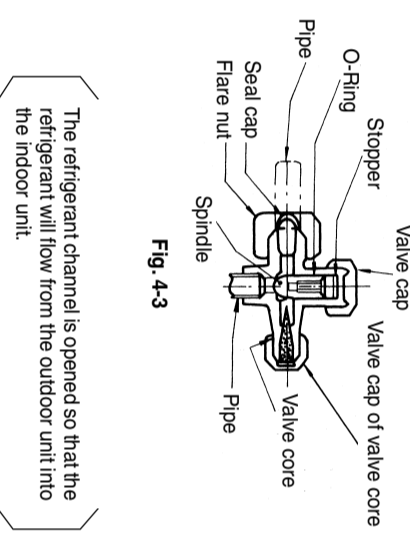
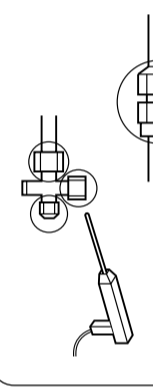

Fig. 4-3

Gas Leakage Inspection

Please use gas leakage detector to check if leakage occurs at connection of flare nut as shown on the right. If gas leakage occurs, further tighten the connection to stop leakage. (Use the detector provided for R410A.)



COOL/HEAT CAPACITY SPEC. FOR INDOOR UNITS COMBINATIONS (Reference value)

POSSIBLE COMBINATIONS TO HEAT	COOLING				HEATING			
	CAPACITY RATING (kW) (RANGE)	POWER CONSUMPTION (W)	AMPERE (A) (20V)	CAPACITY RATING (kW) (RANGE)	POWER CONSUMPTION (W)	AMPERE (A) (20V)	POSSIBLE COMBINATIONS TO HEAT	
1.8	(1.00-2.50)	780	2.5	(2.50-7.50)	650	3.0	1.8	
2.5	(1.00-2.80)	1160	3.4	(3.00-8.00)	780	3.0	2.5	
3.5	(1.00-4.00)	1680	5.1	(3.50-12.80)	1160	4.8	3.5	
5.0	(1.00-5.60)	2400	8.4	(5.00-21.00)	1680	6.1	5.0	
1.8+1.8	(1.80-1.80)	1120	4.9	(2.50-2.90)	650	3.0	1.8+1.8	
1.8+2.5	(1.80-4.10)	1680	5.8	(3.50-5.50)	1160	4.8	1.8+2.5	
1.8+3.5	(1.80-5.80)	2400	7.7	(5.00-8.00)	1680	6.1	1.8+3.5	
1.8+5.0	(1.80-8.20)	3360	11.3	(7.00-12.40)	2400	9.4	1.8+5.0	
2.5+2.5	(2.50-2.50)	1560	6.9	(3.00-3.90)	1160	5.8	2.5+2.5	
2.5+3.5	(2.50-5.80)	2280	8.7	(4.00-6.80)	1680	6.1	2.5+3.5	
2.5+5.0	(2.50-8.20)	3240	11.3	(6.00-9.60)	2400	9.4	2.5+5.0	
3.5+3.5	(3.50-3.50)	2280	11.3	(4.00-5.80)	1680	6.1	3.5+3.5	
3.5+5.0	(3.50-8.20)	3360	14.9	(6.00-10.60)	2400	14.5	3.5+5.0	
5.0+5.0	(5.00-5.00)	3360	14.9	(6.00-10.60)	2400	14.5	5.0+5.0	
1.8+1.8	(1.80-1.80)	1120	4.9	(2.50-2.90)	650	3.0	1.8+1.8	
1.8+2.5	(1.80-4.10)	1680	5.8	(3.50-5.50)	1160	4.8	1.8+2.5	
1.8+3.5	(1.80-5.80)	2400	7.7	(5.00-8.00)	1680	6.1	1.8+3.5	
1.8+5.0	(1.80-8.20)	3360	11.3	(7.00-12.40)	2400	9.4	1.8+5.0	
2.5+2.5	(2.50-2.50)	1560	6.9	(3.00-3.90)	1160	5.8	2.5+2.5	
2.5+3.5	(2.50-5.80)	2280	8.7	(4.00-6.80)	1680	6.1	2.5+3.5	
2.5+5.0	(2.50-8.20)	3240	11.3	(6.00-9.60)	2400	9.4	2.5+5.0	
3.5+3.5	(3.50-3.50)	2280	11.3	(4.00-5.80)	1680	6.1	3.5+3.5	
3.5+5.0	(3.50-8.20)	3360	14.9	(6.00-10.60)	2400	14.5	3.5+5.0	
5.0+5.0	(5.00-5.00)	3360	14.9	(6.00-10.60)	2400	14.5	5.0+5.0	
1.8+1.8+1.8	(1.80-1.80)	1750	7.7	(2.50-2.90)	1980	8.2	1.8+1.8+1.8	
1.8+1.8+2.5	(1.80-4.10)	2580	8.7	(3.50-5.50)	2210	9.7	1.8+1.8+2.5	
1.8+1.8+3.5	(1.80-5.80)	3600	10.1	(5.00-8.00)	2530	10.7	1.8+1.8+3.5	
1.8+1.8+5.0	(1.80-8.20)	4920	14.9	(7.00-12.40)	3530	14.9	1.8+1.8+5.0	
1.8+2.5+2.5	(1.80-5.20)	2550	9.9	(3.50-6.80)	2250	11.1	1.8+2.5+2.5	
1.8+2.5+3.5	(1.80-7.50)	3600	11.0	(5.00-11.20)	2550	11.1	1.8+2.5+3.5	
1.8+2.5+5.0	(1.80-10.00)	4920	14.9	(7.00-12.40)	3530	14.9	1.8+2.5+5.0	
1.8+3.5+3.5	(1.80-7.50)	3600	11.0	(5.00-11.20)	2550	11.1	1.8+3.5+3.5	
1.8+3.5+5.0	(1.80-10.00)	4920	14.9	(7.00-12.40)	3530	14.9	1.8+3.5+5.0	
1.8+5.0+5.0	(1.80-16.40)	6720	21.3	(10.00-16.40)	4860	21.3	1.8+5.0+5.0	
2.5+2.5+2.5	(2.50-2.50)	2280	11.3	(3.00-3.90)	1680	6.1	2.5+2.5+2.5	
2.5+2.5+3.5	(2.50-5.80)	3360	14.9	(4.00-6.80)	2400	9.4	2.5+2.5+3.5	
2.5+2.5+5.0	(2.50-8.20)	4680	19.4	(6.00-9.60)	3360	12.5	2.5+2.5+5.0	
2.5+3.5+3.5	(2.50-7.50)	3600	11.0	(5.00-11.20)	2550	11.1	2.5+3.5+3.5	
2.5+3.5+5.0	(2.50-10.00)	4920	14.9	(7.00-12.40)	3530	14.9	2.5+3.5+5.0	
2.5+5.0+5.0	(2.50-16.40)	6720	21.3	(10.00-16.40)	4860	21.3	2.5+5.0+5.0	
3.5+3.5+3.5	(3.50-3.50)	2280	11.3	(4.00-5.80)	1680	6.1	3.5+3.5+3.5	
3.5+3.5+5.0	(3.50-8.20)	3360	14.9	(5.00-11.20)	2550	11.1	3.5+3.5+5.0	
3.5+5.0+5.0	(3.50-16.40)	4920	21.3	(7.00-12.40)	3530	14.9	3.5+5.0+5.0	
5.0+5.0+5.0	(5.00-5.00)	3360	14.9	(6.00-10.60)	2400	14.5	5.0+5.0+5.0	
1.8+1.8+1.8+1.8	(1.80-1.80)	2280	11.3	(2.50-2.90)	1680	6.1	1.8+1.8+1.8+1.8	
1.8+1.8+1.8+2.5	(1.80-4.10)	3360	14.9	(3.50-5.50)	2210	9.7	1.8+1.8+1.8+2.5	
1.8+1.8+1.8+3.5	(1.80-5.80)	4680	19.4	(5.00-8.00)	3360	12.5	1.8+1.8+1.8+3.5	
1.8+1.8+1.8+5.0	(1.80-8.20)	6360	26.7	(7.00-12.40)	4530	26.7	1.8+1.8+1.8+5.0	
1.8+1.8+2.5+2.5	(1.80-7.50)	4680	19.4	(5.00-11.20)	3360	12.5	1.8+1.8+2.5+2.5	
1.8+1.8+2.5+3.5	(1.80-10.00)	6360	26.7	(7.00-12.40)	4530	26.7	1.8+1.8+2.5+3.5	
1.8+1.8+2.5+5.0	(1.80-16.40)	8160	34.0	(10.00-16.40)	5760	34.0	1.8+1.8+2.5+5.0	
1.8+1.8+3.5+3.5	(1.80-10.00)	6360	26.7	(7.00-12.40)	4530	26.7	1.8+1.8+3.5+3.5	
1.8+1.8+3.5+5.0	(1.80-16.40)	8160	34.0	(10.00-16.40)	5760	34.0	1.8+1.8+3.5+5.0	
1.8+1.8+5.0+5.0	(1.80-22.80)	10080	42.3	(14.00-22.80)	7260	42.3	1.8+1.8+5.0+5.0	
2.5+2.5+2.5+2.5	(2.50-2.50)	2280	11.3	(3.00-3.90)	1680	6.1	2.5+2.5+2.5+2.5	
2.5+2.5+2.5+3.5	(2.50-5.80)	3360	14.9	(4.00-6.80)	2400	9.4	2.5+2.5+2.5+3.5	
2.5+2.5+2.5+5.0	(2.50-8.20)	4680	19.4	(6.00-9.60)	3360	12.5	2.5+2.5+2.5+5.0	
2.5+2.5+3.5+3.5	(2.50-7.50)	3600	11.0	(5.00-11.20)	2550	11.1	2.5+2.5+3.5+3.5	
2.5+2.5+3.5+5.0	(2.50-10.00)	4920	14.9	(7.00-12.40)	3530	14.9	2.5+2.5+3.5+5.0	
2.5+2.5+5.0+5.0	(2.50-16.40)	6720	21.3	(10.00-16.40)	4860	21.3	2.5+2.5+5.0+5.0	
3.5+3.5+3.5+3.5	(3.50-3.50)	2280	11.3	(4.00-5.80)	1680	6.1	3.5+3.5+3.5+3.5	
3.5+3.5+3.5+5.0	(3.50-8.20)	3360	14.9	(5.00-11.20)	2550	11.1	3.5+3.5+3.5+5.0	
3.5+3.5+5.0+5.0	(3.50-16.40)	4920	21.3	(7.00-12.40)	3530	14.9	3.5+3.5+5.0+5.0	
5.0+5.0+5.0+5.0	(5.00-5.00)	3360	14.9	(6.00-10.60)	2400	14.5	5.0+5.0+5.0+5.0	
1.8+1.8+1.8+1.8+1.8	(1.80-1.80)	2880	13.3	(2.50-2.90)	2040	7.1	1.8+1.8+1.8+1.8+1.8	
1.8+1.8+1.8+1.8+2.5	(1.80-4.10)	4200	19.4	(3.50-5.50)	2970	10.7	1.8+1.8+1.8+1.8+2.5	
1.8+1.8+1.8+1.8+3.5	(1.80-5.80)	5520	26.7	(5.00-8.00)	3960	14.5	1.8+1.8+1.8+1.8+3.5	
1.8+1.8+1.8+1.8+5.0	(1.80-8.20)	7440	36.0	(7.00-12.40)	5280	36.0	1.8+1.8+1.8+1.8+5.0	
1.8+1.8+1.8+2.5+2.5	(1.80-7.50)	5520	26.7	(5.00-11.20)	3960	14.5	1.8+1.8+1.8+2.5+2.5	
1.8+1.8+1.8+2.5+3.5	(1.80-10.00)	7440	36.0	(7.00-12.40)	5280	36.0	1.8+1.8+1.8+2.5+3.5	
1.8+1.8+1.8+2.5+5.0	(1.80-16.40)	9360	45.3	(10.00-16.40)	6660	45.3	1.8+1.8+1.8+2.5+5.0	
1.8+1.8+1.8+3.5+3.5	(1.80-10.00)	7440	36.0	(7.00-12.40)	5280	36.0	1.8+1.8+1.8+3.5+3.5	
1.8+1.8+1.8+3.5+5.0	(1.80-16.40)	9360	45.3	(10.00-16.40)	6660	45.3	1.8+1.8+1.8+3.5+5.0	
1.8+1.8+1.8+5.0+5.0	(1.80-22.80)	11280	54.6	(14.00-22.80)	8160	54.6	1.8+1.8+1.8+5.0+5.0	
2.5+2.5+2.5+2.5+2.5	(2.50-2.50)	2880	13.3	(3.00-3.90)	2040	7.1	2.5+2.5+2.5+2.5+2.5	
2.5+2.5+2.5+2.5+3.5	(2.50-5.80)	4200	19.4	(4.00-6.80)	2970	10.7	2.5+2.5+2.5+2.5+3.5	
2								