

For service personnel only

HITACHI

Inspire the Next

SPLIT TYPE

INDOOR UNIT/OUTDOOR UNIT

INSTALLATION MANUAL

MODEL RAS-14CHR / RAC-14CHR

Accessories of indoor unit:

No.	Item	Q'ty
1	Hanger	1
2	4.1 x 32 Screw	6
3	Holder for remote controller	1
4	3.1 x 16 Screw	2
5	Battery	2
6	Remote controller	1
7	Bush	3
8	Drain Pipe	1

* **NOTE**

Cut the insulation pipe to 800mm, and use it in case of drawing the pipes from left side.

CAUTION

1. Power cord of this unit is supplied. An IEC approved plug must be connected to the power cord.
2. Pipes and wirings must not be drawn from the right side (near the electric part) of the indoor unit and the bush on right side must not be cut off.
3. An IEC approved flexible interconnection cord must be supplied.
4. Should any unexpected fault occur due to a reaction from the distributing mains, please call our after-sales service.
5. The height of indoor unit shall be $\geq 2.5\text{m}$ from floor.
6. The maximum permitted POWER NETWORK IMPEDANCE is $Z = 0.387 \text{ Ohm}$.

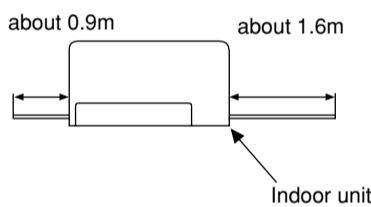

Fig. 1 Length of power cord

If you wish to prepare the copper tubes and insulation material in the field, we recommend the following.

No.	Material	Specification
1	Small dia. copper tube	Deoxidized annealed copper tube 6.35mm O.D with 0.76mm wall thickness
2	Large dia. copper tube	Deoxidized annealed copper tube 12.7mm O.D with 1.0mm wall thickness
3	Flare nut	<ul style="list-style-type: none"> ● 2 Flare nuts 6.35mm O.D pipe ● 2 Flare nuts 12.7mm O.D pipe
4	Insulation for refrigerating pipe	Foamed polyethylene insulation pipe which does not corrode the copper tube. <ul style="list-style-type: none"> ● Large dia. pipe size; 15mm I.D. 8mm wall thickness. Small dia. pipe size; 8mm I.D. 7mm wall thickness.
5	Copper wire	Refer to item 2.1.

We recommend you prepare these additional materials to complete the installation.

Additional materials

- Vinyl tape
- Refrigerator oil
- Sealer (Pate)
- Bush for refrigerating pipes

CONDENSED WATER DISPOSAL OF OUTDOOR UNIT

- There are holes on the base of outdoor unit for condensed water to exhaust.
- In order for condensed water to flow to the draining port, installed the unit on the level ground or block so that the unit is 100mm above the ground, same as figure shown. Join the drain pipe to one hole and cover the rest with bushes. If there are other holes or gaps, cover them with putty to prevent water from leaking out.

At first insert one portion of the hook to the base (Portion A), then pull the drain pipe in the direction shown by the arrow while inserting the hook into the base. After installation, check whether the drain pipe cling to the base firmly.

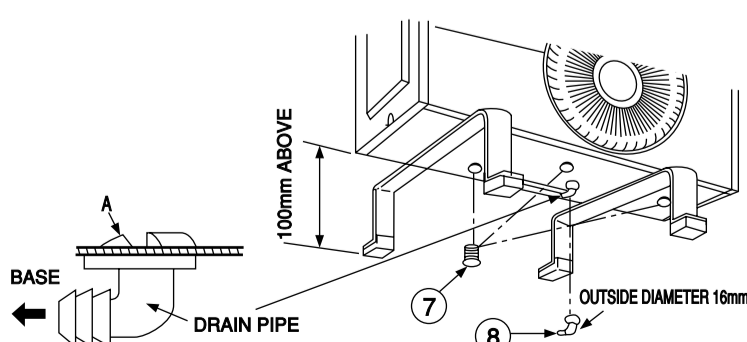

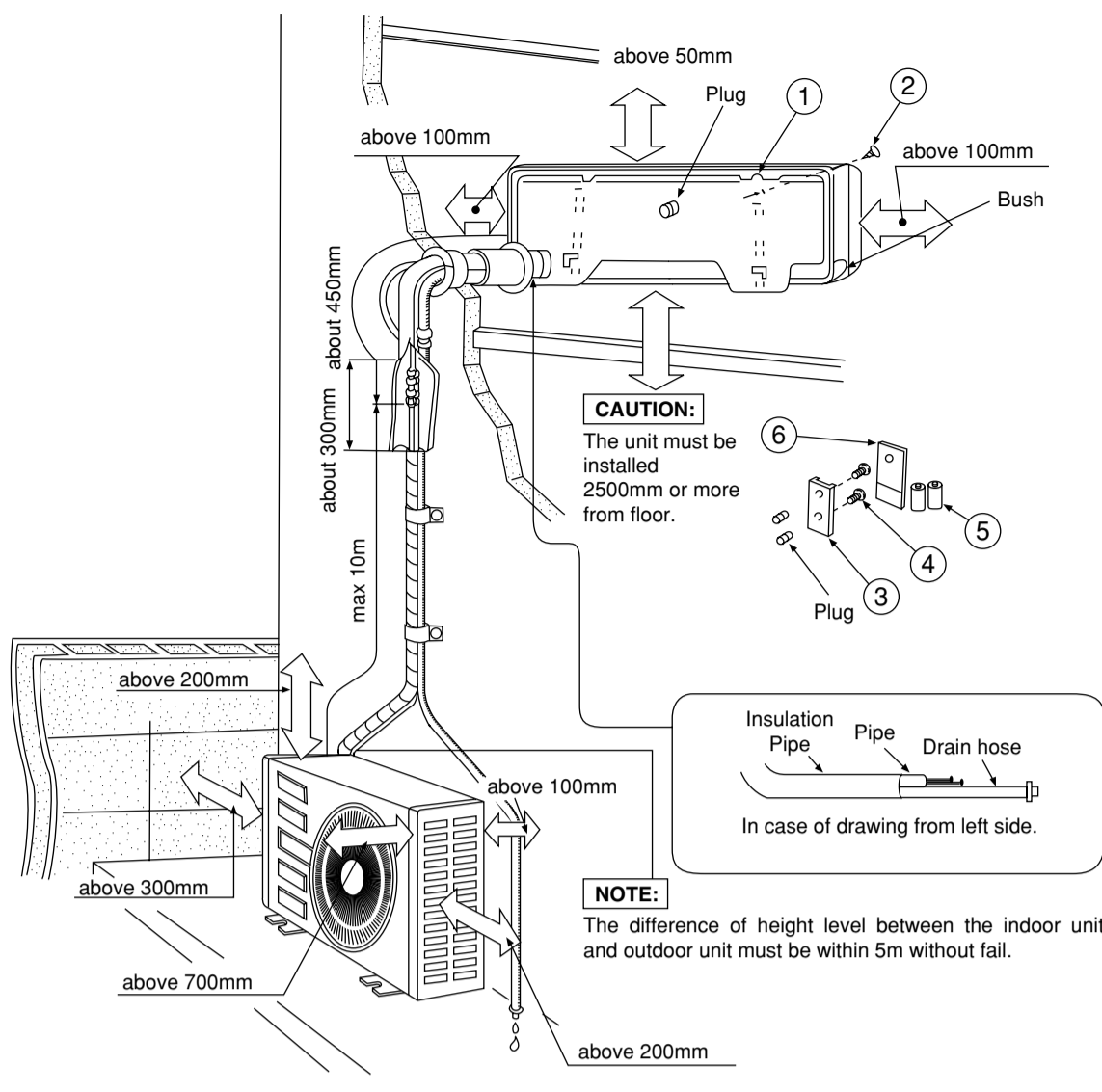

• Leave a space as shown by ⇄ in the above diagram at the top, left, right and rear of the unit. Further, it should be open in two or more directions.

CAUTION

In case the pipe length exceeds 8m, (which connect the indoor unit to the outdoor unit), add refrigerant (R-22) at 25g/m as below table. However, pipe length shall not exceed 10m.

Pipe length (m)	Additional R-22 quantity (g)
~8	0
9	25
10	50

Fig. 2 Installation-completion

1. Proper place for installation

1.1 Indoor unit

- Keep the space around the indoor unit, considering the after service.
 - upper side above 50mm
 - left side above 100mm
 - right side above 100mm
- Indoor unit should be installed so that its height from the floor is 2500mm or more.
- Refrigerating pipes can be drawn from back, under, left side of the indoor unit. In the case that refrigerating pipes are drawn from the left side, confirm the smooth flowing of condensed water. If not, the condensed water will overflow in the room. When the pipes are drawn from the right or the left side, the pipes can be connected easily by configuring the pipes before installation.

1.2 Outdoor unit

- Keep the space around the unit for the maintenance and avoiding the effects of hindrance for normal ventilation of the unit as shown in Fig. 2.
- The northern or eastern side of the building is better to install. At the installation on the southern or western side unavoidably, some blind should be set up for the unit. (In this case, the blind must not be obstructed the ventilation of the unit.)
- You'd better not put the unit at a place where is full of dirt and at a place where is wet in the rain.
- Place as nearer as possible to the indoor unit.

Note: The difference of height level between the indoor unit and outdoor unit must be within 5m without fail.

2. Checking for the electric source and the voltage range

2.1 Before installation, the power source must be checked and necessary wiring work must be completed. To make the wiring capacity proper, use the wire gauges list below for the lead-in from a pole transformer and for the wiring from a switch board of fuse box to the outlet in consideration of the locked rotor current.

IMPORTANT

Cable length	Wire cross-section
up to 6 m	1.5 mm ²
up to 15 m	2.5 mm ²
up to 25 m	4.0 mm ²

2.2 Investigate the power supply capacity and other electrical conditions at the installing location. Depending on the model of room air conditioner to be installed, request the customer to make arrangements for the necessary electrical work etc. The electrical work includes the wiring work up the outlet. In localities where electrical conditions are poor, use of a voltage regulation is recommended.

2.3 Install outlet for the room air conditioner within the reaching range of the line cord.

2.4 In the installation, a separator with a contact gap of more than 3mm has to be installed. During cleaning or service the set has to be switched off with this separator.

USE A FUSE AS FOLLOWING

IMPORTANT

Model	Fuse Capacity
RAS-14CHR / RAC-14CHR	15A time delay fuse

3. Installation procedure and notice

Especially, the selection of installation place need great care for the split type air conditioner, because it's very difficult to move from place to place after the first installation.

3.1 Make a hole on the wall such the place as shown in Figs. 3-4.
In order to keep the smooth flowing of condensed water.

3.2 Installation of indoor unit

Indoor unit is installed by hangers.

- (1) Make holes on the wall with dim $\phi 4.8\text{mm} \times 32\text{mm}$. (Fig. 3-1)
- (2) Insert the plugs.
- (3) Fix the hanger to the wall with 4.1 x 32mm screws no. ② horizontally. (Fig. 3-3)

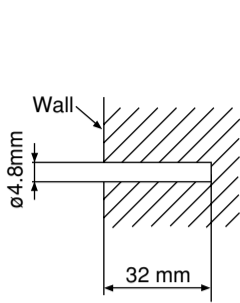

Fig. 3-1

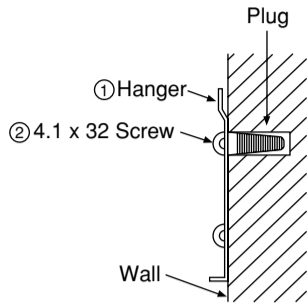

Fig. 3-2

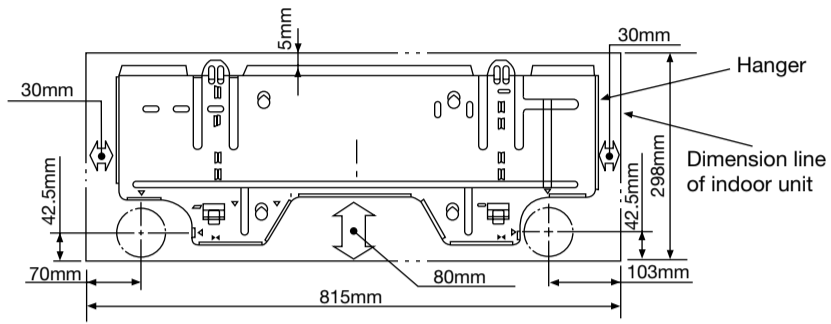

Fig. 3-3

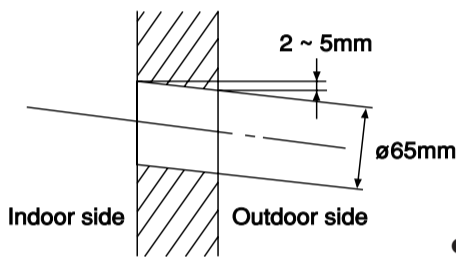
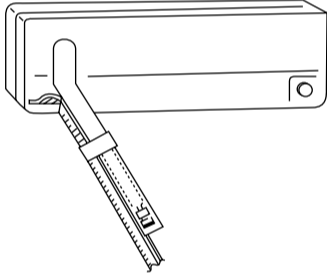

Fig. 3-4

- Hole on wall should be made with some inclination like Fig. 3-4 for keeping the smooth flowing of the condensed water.

3.3 Direction of drawing the refrigerating pipe (Indoor unit)

- (1) In case of drawing the refrigerating pipe to the backside of unit, fix the refrigerating pipe, drain hose and connecting cords with the vinyl tape at several spots. Attach the holder of refrigerating pipe to the back of unit certainly. (Fig. 3-5)



Fix the refrigerating pipe, drain hose and connecting cords with vinyl tape.

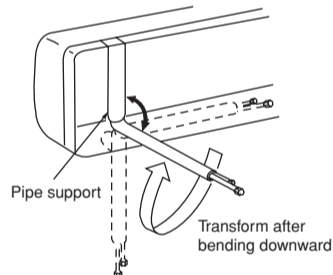

Transform the piping while holding down the lower portion of pipe-support by hand.

Fig. 3-5

- (2) In the case that the refrigerating pipes are drawn from the under left side, cut off the bush and insert the pipe in it. (Fig. 3-6)

- Vertical drop installation

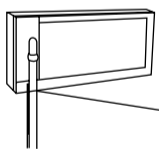
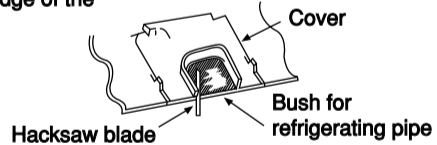

Fig. 3-6

Cut away the shaded portion, and finish the edge of the opening so that there is no burr.



IMPORTANT

- (3) In case that the refrigerating pipes are drawn from the left side, remove the drain hose and the drain cap, and insert them exactly up to the projection of insulator as shown in the following drawings. (If they are not inserted exactly, the condensed water might leak and drop.) (Fig. 3-7)

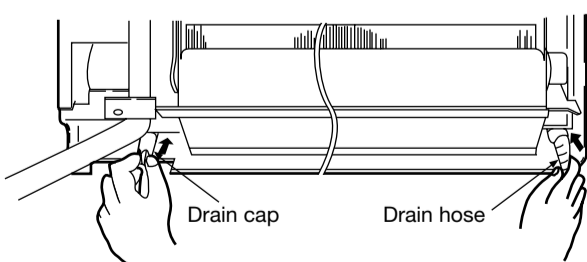
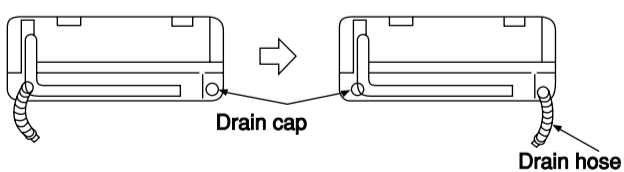

Drain cap is removed easily, it shall be turns by a plier.

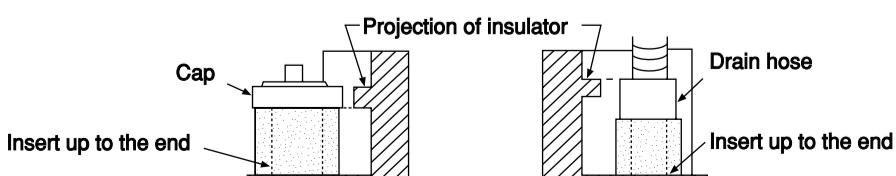
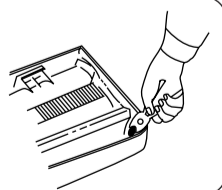

Fig. 3-7

3.4 Pre-piping procedure

In the case of installation after connecting the refrigerating pipes.

- (1) Trim the refrigerating pipes to fit in hole of the wall and connect them.
- (2) Connect the connecting cords.
- (3) Trim the connecting cords and the refrigerating pipes, put them in the back space of unit.

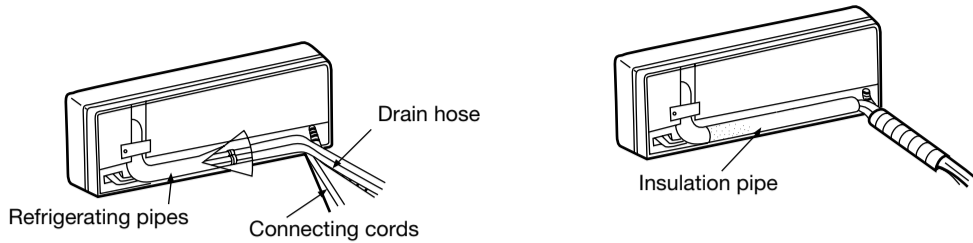

Fig. 3-8

3.5 The connecting when the refrigerating pipes are drawn from the left side

The bottom of unit is lifted forward.

- (1) Insert the drain hose to the wall hole.
- (2) After connecting of the refrigerating pipes, cover the connecting parts by insulator.
- (3) The refrigerating pipes are covered with the insulator pipe.
- (4) Connect connecting cords.
- (5) Trim the connecting cords and the refrigerating pipes, put them in the back side space of unit.
- (6) Put projection of unit in hook of the hanger.

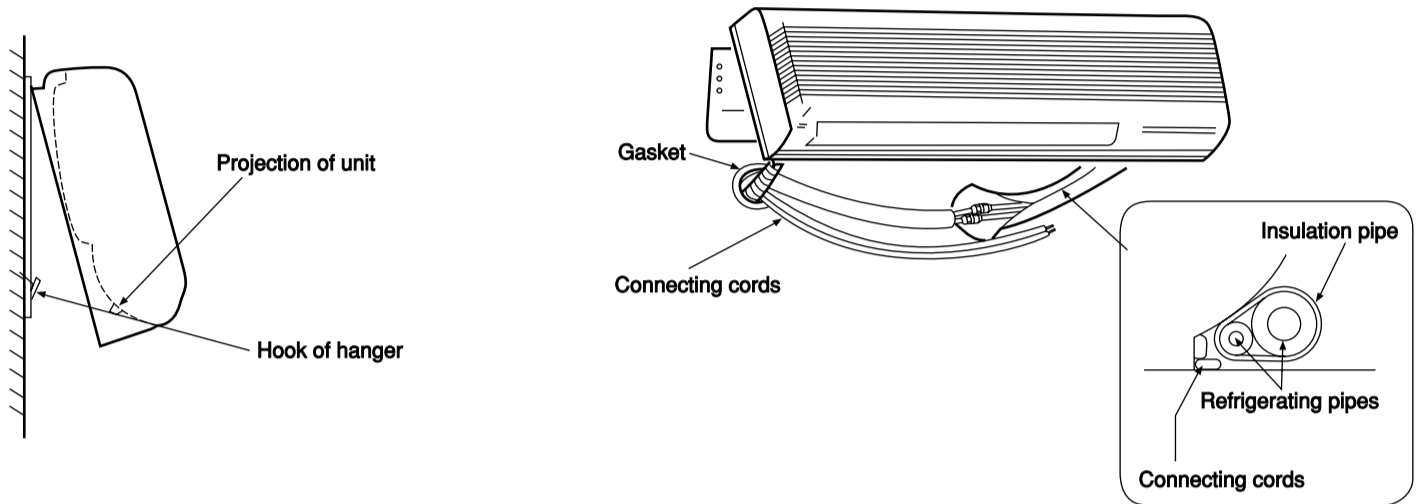

Fig. 3-9

[Pipe cutting and flaring]

1. Cut the pipe using a pipe cutter and deburr it without fail.

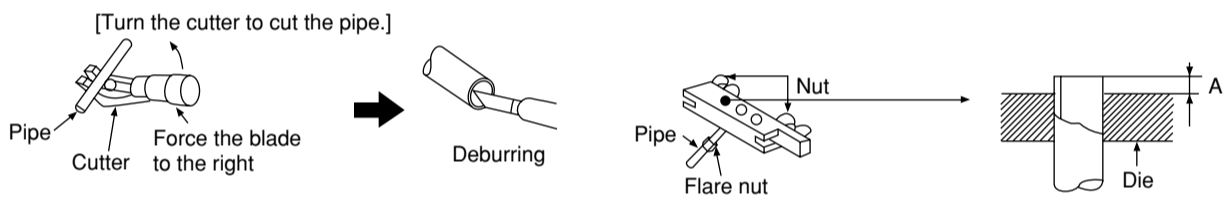

Fig. 3-10

- For no saw dust to enter, direct the copper pipe downward.

Out. dia. (mm)	A	
	Imperial flaring tool	Rigid flaring tool
6.35	0.8 ~ 1.5 mm	0 ~ 0.5 mm
12.7	1.0 ~ 2.0 mm	0 ~ 1.0 mm

2. Using a flaring tool, flare the pipe end with the flare nut inserted into the pipe and without fail.

3.6 Wiring

- (1) Connect the electrical wiring between the indoor and outdoor unit as shown in Fig. 3-11. Never connect the wiring by mistake.
- (2) The connecting cord must be fixed by the band which is located on the electrical box.

EARTHING

WARNING - THIS APPLIANCE MUST BE EARTHED.

IMPORTANT:

The wires in this mains lead are coloured in accordance with the following code:

Green-and-yellow: Earth

As the colours of the wires in the mains lead of this appliance may not correspond with the coloured markings identifying the terminals in your plug, proceed as follows.

The wire which is coloured green-and-yellow must be connected to the terminal in the plug which is marked with the earth symbol or coloured green-and-yellow.

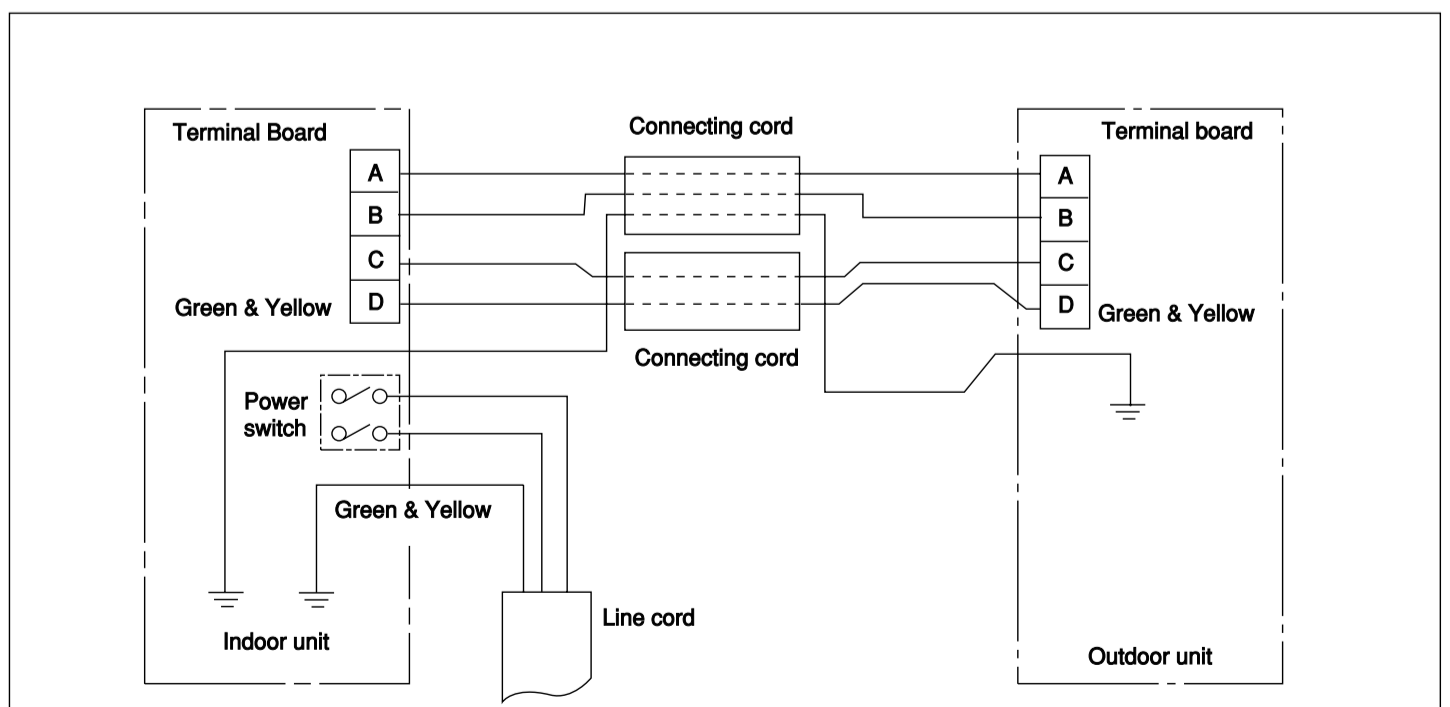

Fig. 3-11

3.7 Connection of the connecting cord (Indoor Unit)

(1) Remove the front cover

- Remove the cap and screw as shown in Fig. 3-12.
- Pull the center of the front cover and release the hook.
- Remove the screw and the cover of electric box.

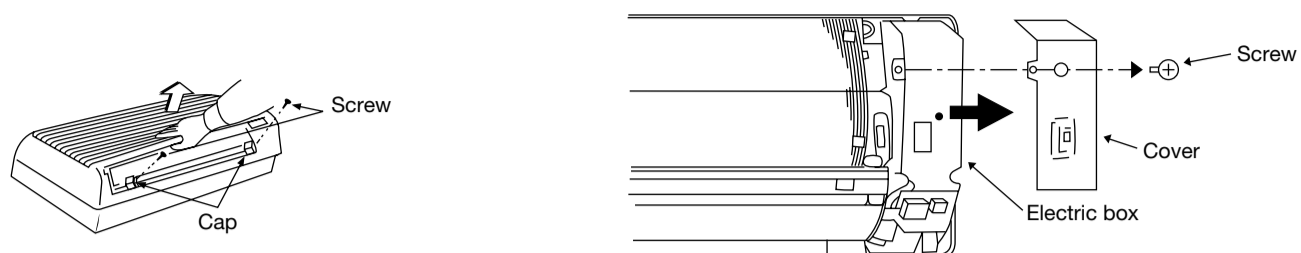

Fig. 3-12

(2) Connect the connecting cords as figure 3-13.

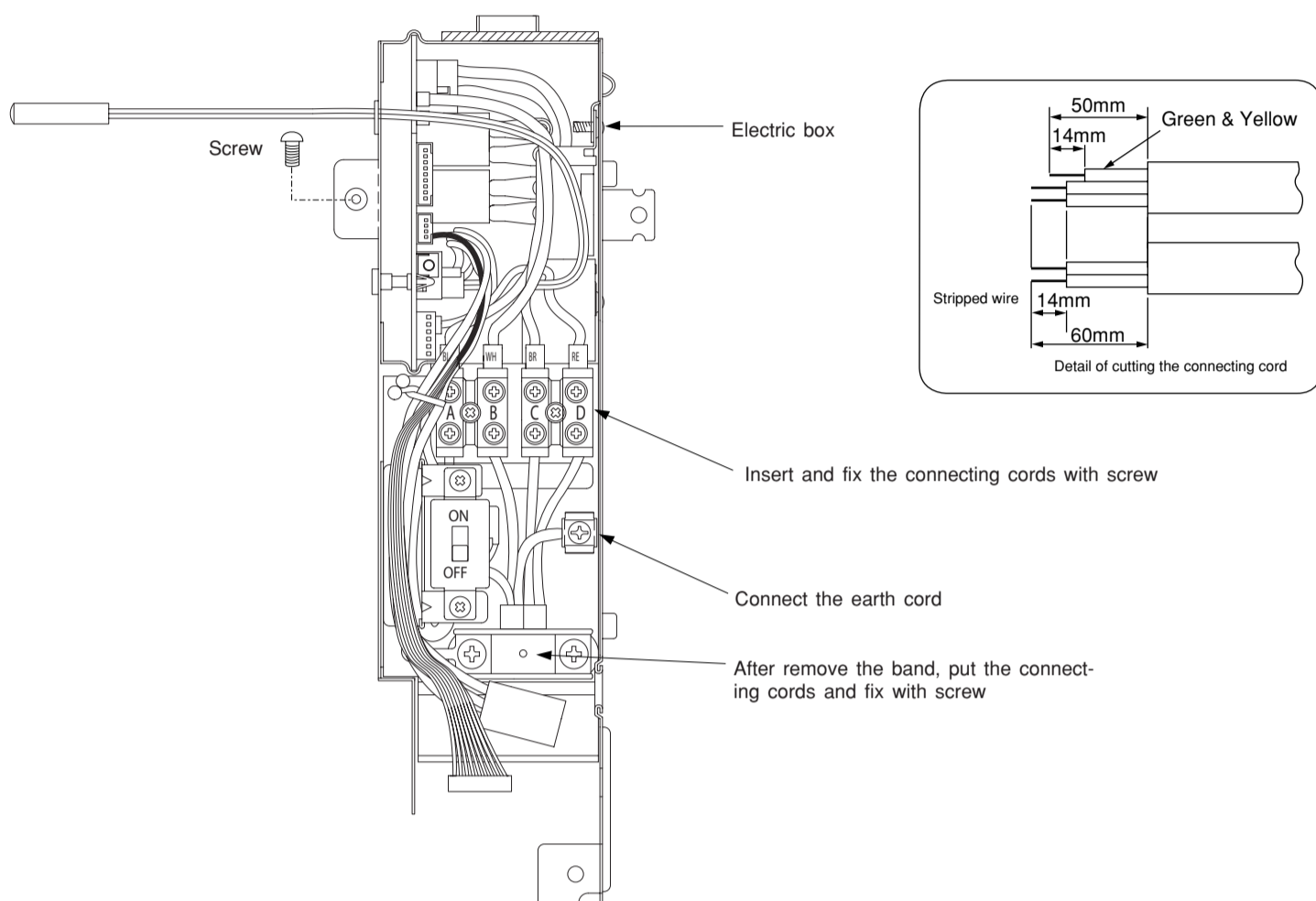

Fig. 3-13

(3) Assemble the cover of electric box and the front cover.

- Assemble the cover of electric box with screw.
- Assemble the front cover.
- Put the hooks (two portions) of front cover upper side certainly.
- Fix the front cover with screw and put the cap to cover the screw.
- Open the suction grille, push the center of front cover downward as arrow and fit the center hook of front cover. (Fig. 3-14)

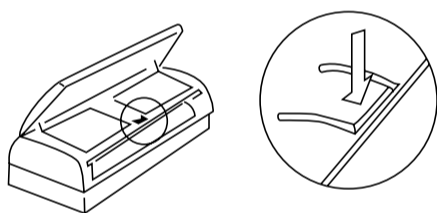

Fig. 3-14

3.8 Installation of indoor unit

(1) Pass the connecting cord, drain hose and pipes through the hole of the wall in turn.

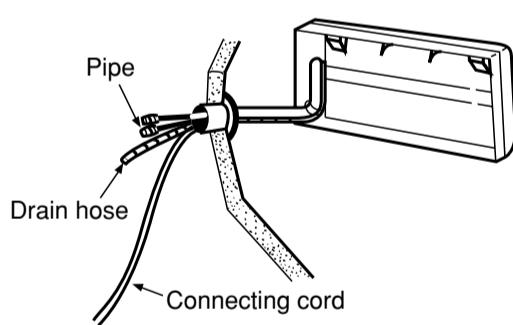

Fig. 3-15

(2) Hook the upper part of the indoor unit to the hanger.

(3) Fit the projection of the lower part of the indoor unit to the hook of the hanger.

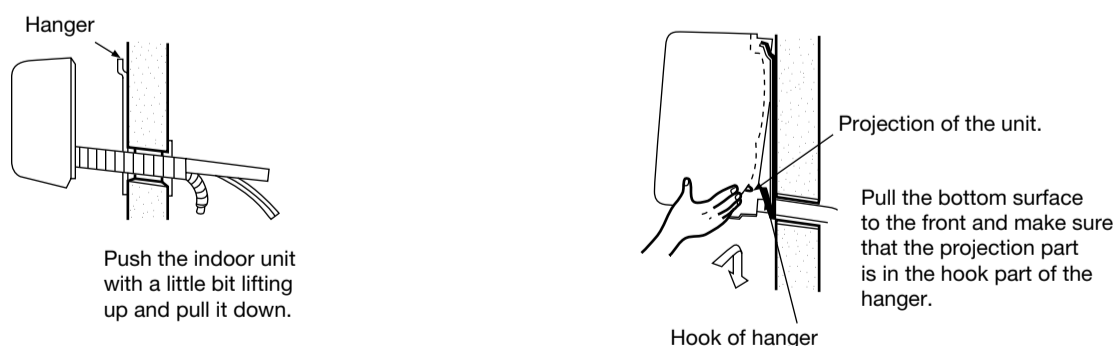

Fig. 3-16

- When removing the indoor unit, perform in reverse order.

3.9 Connecting the pipe

Connecting the pipe to indoor unit

- (1) Remove the flare nut and seal cap.

By loosening the flare nut at the pipe end, the refrigerant is discharged in a small amount. This arrangement has been made for shipment, and the discharge of refrigerant is never a trouble of the equipment.

When the flare nut is removed, never fail to remove the seal cap. Or, the refrigerant will not be circulated, with the result that the compressor drive motor will possibly be burnt.

- (2) Apply a refrigerator oil to the union and the flared portion of the pipe.

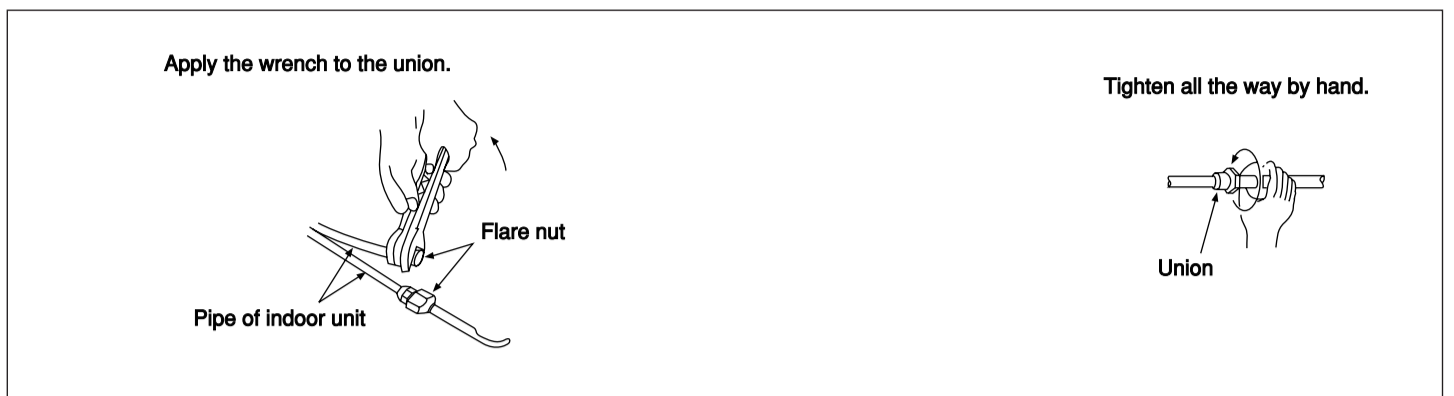

Fig. 3-17

Pipe out dia.	(mm)	Description of wrench	(mm)	Torque	(kgf-cm)
Small dia. pipe side	6.35	17		140 ~ 190	
Large dia. pipe side	12.7	24		450 ~ 550	

- (3) Use two wrenches as shown, securely tighten.

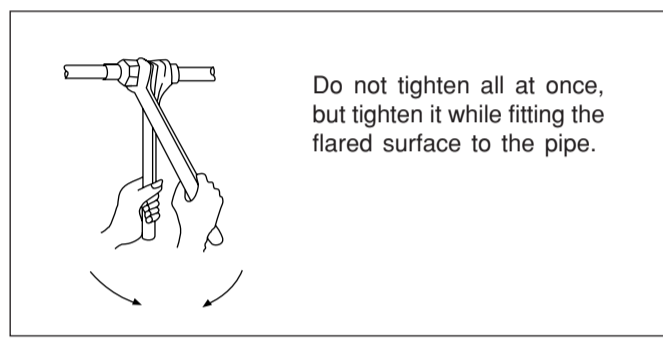

Fig. 3-18

Sealing the refrigerating pipe

- (1) Wrap the insulation around the couplings of indoor unit without gap and fix the refrigerating pipe.

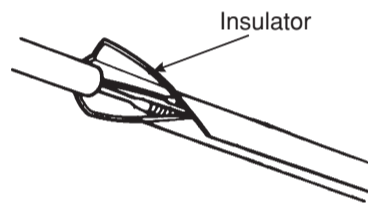

Fig. 3-19

Connecting the pipe to outdoor unit

- (1) Remove the side plate.
- (2) Remove the flare nut and seal cap from the service valve.

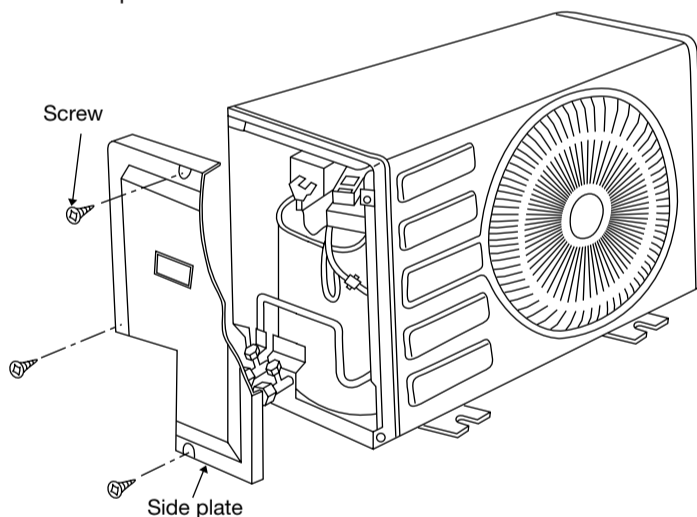

Fig. 3-20

- (3) Apply a refrigerator oil to the service valve and the flared portion of the pipe.
- (4) Using a wrench, securely tighten.

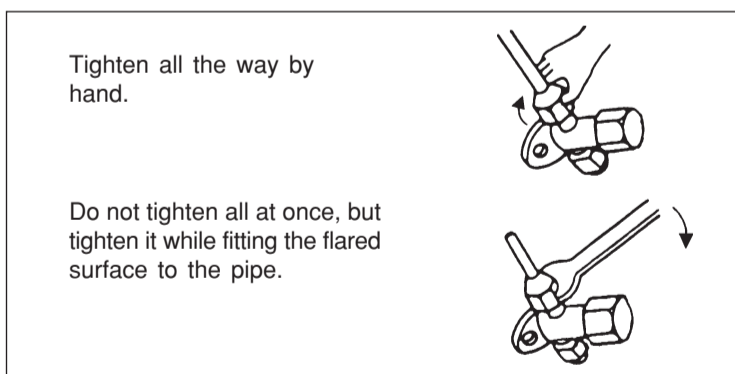

Fig. 3-21

3.10 Connection of the connecting cords. (Outdoor unit)

- (1) Cut off the connecting cords and strip the insulation of wire. (Fig. 3-22)
- (2) Connect the connecting cords to the terminal board. (Fig. 3-23)
- (3) Fix the connecting cords with the bands certainly. (Fig. 3-23)

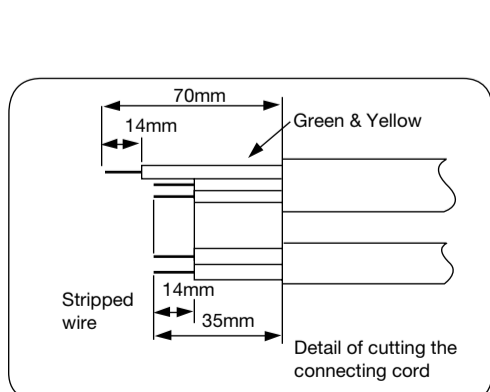

Fig. 3-22

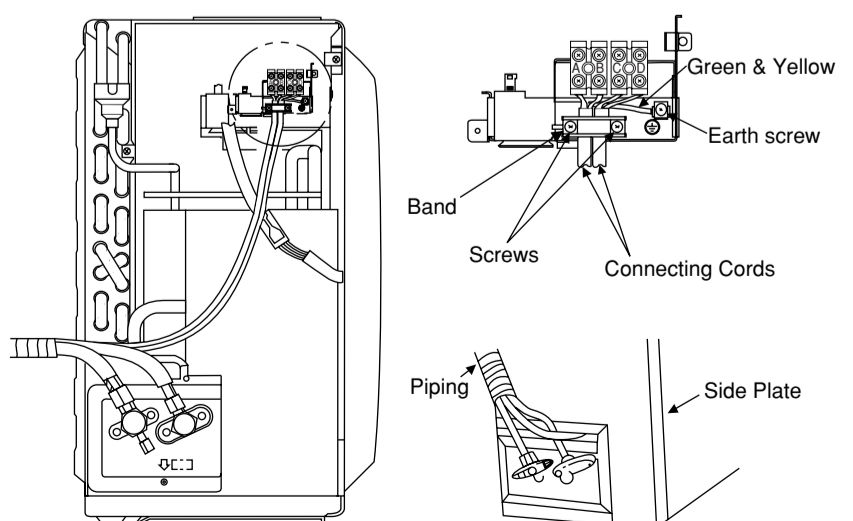

Fig. 3-23

4. Air-purging

After completing the piping, purge the air from the connected pipe and indoor unit. If this work is not done, the discharge pressure will abnormally rise so that the refrigerating-cycle unit will possibly be damaged or inoperable.

4.1 Air-purging by using vacuum pump

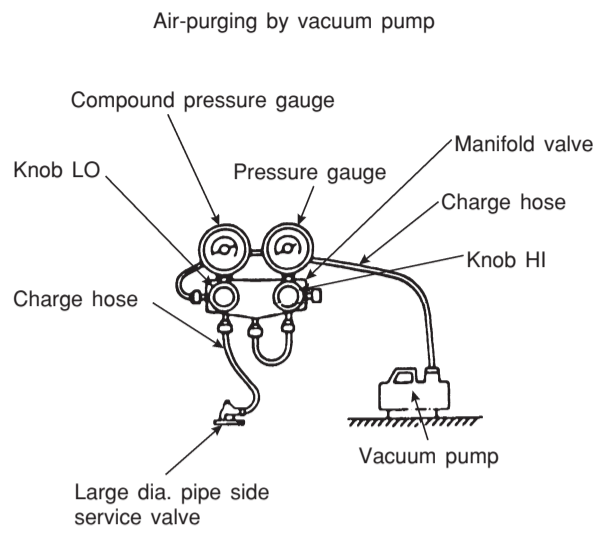
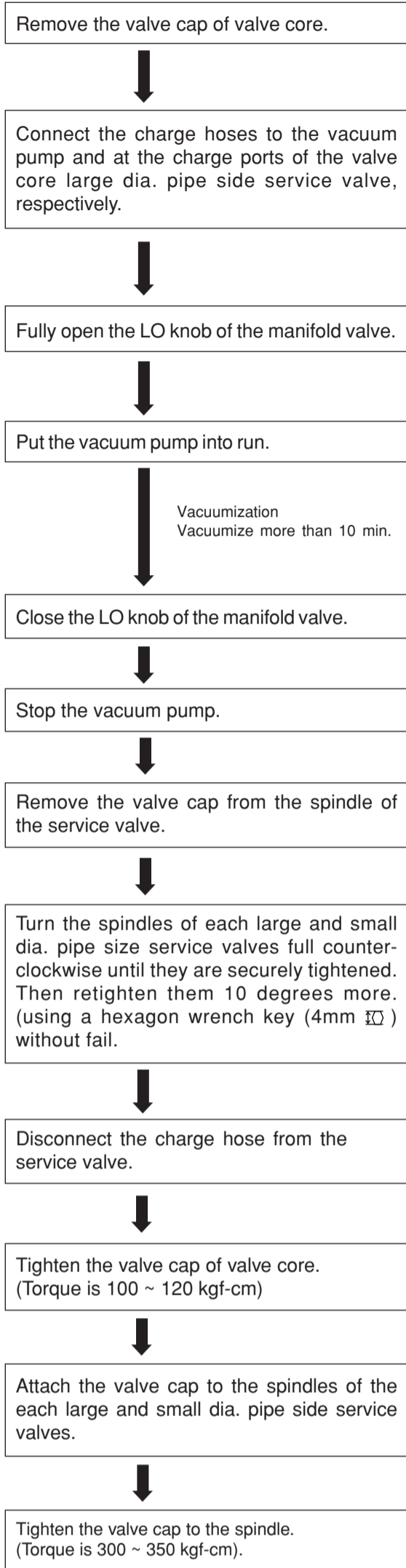

Fig. 4-1

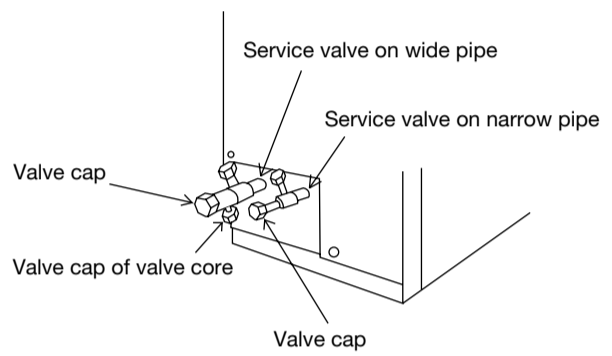

Fig. 4-2

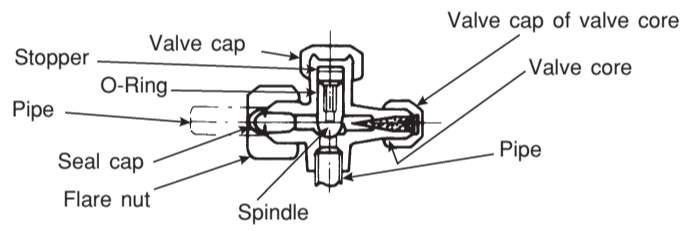

Fig. 4-3

The refrigerant channel is opened so that the refrigerant will flow from the outdoor unit into the indoor unit.

5. Checking of drawing drain hose

- Connect the separate drain hose to the drain hose that is attached to the unit.
- For keeping the smooth flowing of condensed water, the drain hose should be inclined as shown in Fig. 5.

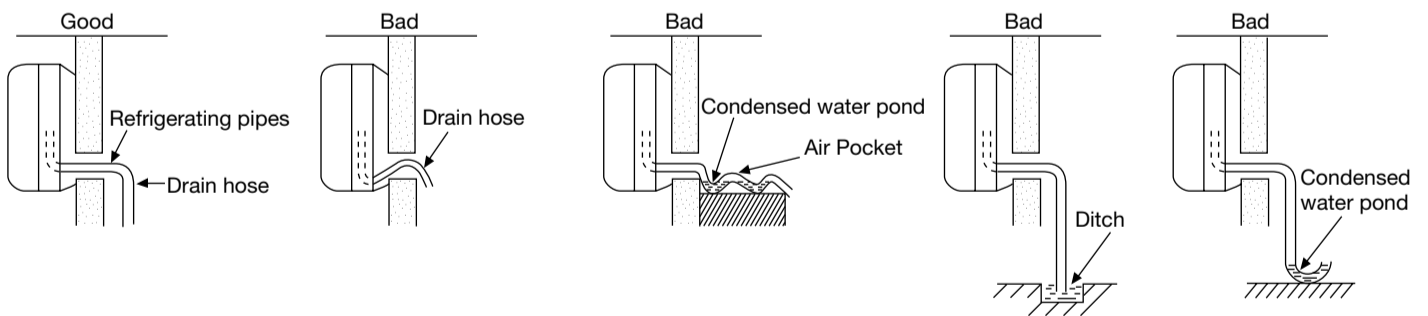

Fig. 5

6. Fixing the remote controller

- Drill holes on wall. (As shown below)
- Push plug into the holes. (As shown below)

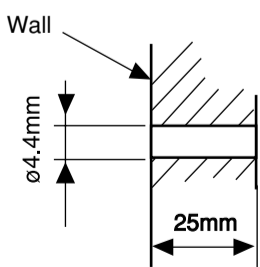

Fig. 6-1

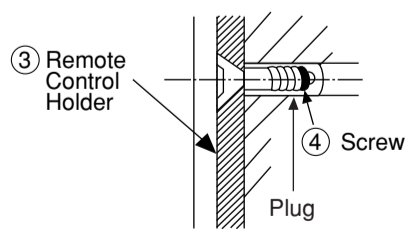

Fig. 6-2

7. Checking procedure after installation

7.1 Confirm the smooth water flowing from the drain hose by pouring some water into the evaporator pan.

7.2 Arrange the penetrating part of the wall presentably with the bush for refrigerating pipes and sealer which is belonging to the pipe set as shown in Figs. 7-1, 7-2 and 7-3.

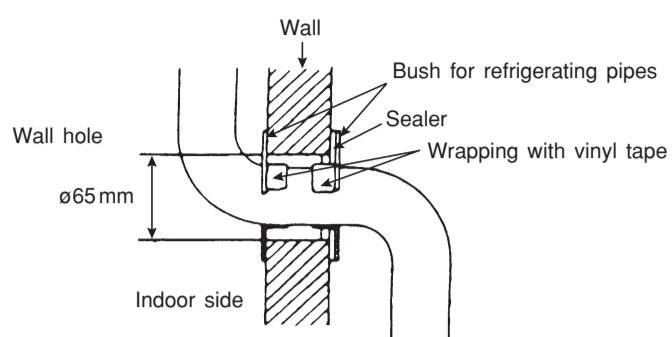

Fig. 7-1

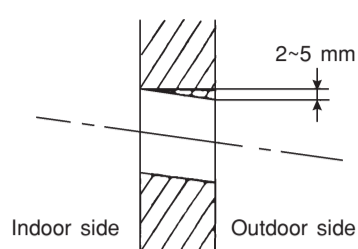

Fig. 7-2

- Hole on wall should be made with some inclination like Fig. 7-2 for keeping the smooth flowing of the condensed water.

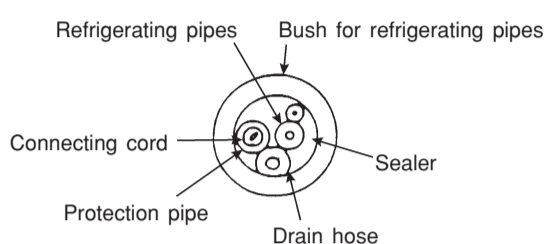

Fig. 7-3

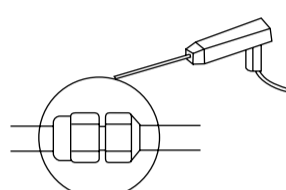

Fig. 7-4

7.3 Wind the inadhensive vinyl tape around the refrigerating pipes and the connecting cord.

7.4 Leakage checking of refrigerant at the coupling by gas leak detector or soapsuds, as shown in Fig. 7-4.

7.5 Checking of evaporator coldness (cooling operation)

7.6 Checking of warm wind from outdoor (cooling operation)

8. Service switch

(1) Confirm the Service switch is set to "NORMAL". (Fig. 8)

(2) The knob should be set to normal position. The knob can be used for cooling operation continuously as temporary measures.

When room air conditioner can not be operated in spite of pressing MAIN OPERATION button and conforming the position of each knob on the remote control switch, this service switch can be used for cooling operation till service man coming.

In cooling operation, set the knob to under position. But this case of cooling operation is continuous operation, be careful not to make cool too much.

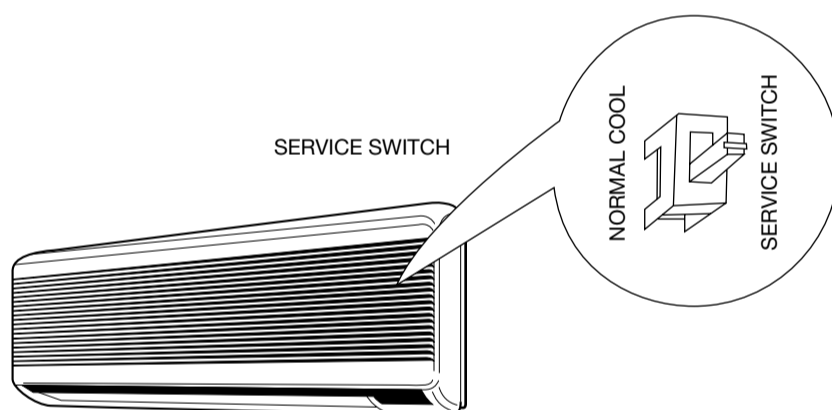

Fig. 8