

HITACHI

Inspire the Next

日立牌

WINDOW TYPE ROOM AIR CONDITIONER

窗式冷氣機

OPERATION AND INSTALLATION MANUAL

安裝使用說明書

MODEL
型號

RA-08JF1
RA-10JF1

CONTENTS

Safety Precaution.....	2
Parts Identification and Operations	3
Control Panel	3
How To Use	3 ~ 6
Maintenance	7 ~ 8
Installation Instructions	9 ~ 12

目錄

安全上應特別注意之事項	13
部件名稱及操作.....	14
控制板	14
使用法	14 ~ 17
維修保養	18 ~ 19
安裝方法	20 ~ 23

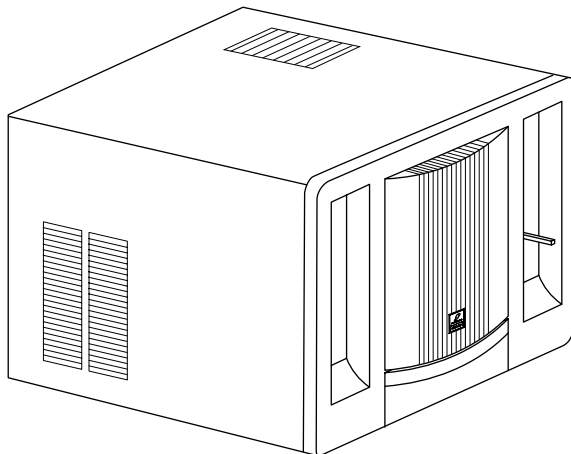



SAFETY PRECAUTION

- Please read the “Safety Precaution” carefully before operating the unit to ensure correct usage of the unit.
- Pay special attention to signs of “▲ Warning” and “▲ Caution”. The “Warning” section contains matters which, if not observed strictly, may cause death or serious injury. The “Caution” section contains matters which may result in serious consequences if not observed properly. Please observe all instructions strictly to ensure safety.
- “⊘” sign in attached figure indicates prohibition.
- Please keep this manual after reading.

PRECAUTIONS DURING INSTALLATION

▲ WARNING	<ul style="list-style-type: none"> ● Please ask your sales agent or qualified technician for the installation of your unit. Water leakage, short circuit or fire may occur if you install the unit yourself. 	
▲ CAUTION	<ul style="list-style-type: none"> ● Please use earth line. Do not place the earth line near water or gas pipes, lightning-conductor or the earth line of telephone. Improper installation of earth line may cause electric shock. ● A circuit breaker should be installed depending on the mounting site of the unit. Without a circuit breaker, the danger of electric shock exists. ● Do not install near location where there is flammable gas. The unit may catch fire if flammable gas leaks around it. ● Please ensure smooth flow of water when installing the drain hose. (For drain model) 	

PRECAUTIONS DURING SHIFTING OR MAINTENANCE

▲ WARNING	<ul style="list-style-type: none"> ● Should abnormal situation arises (like burning smell), please stop operating the unit and turn off the circuit breaker. Contact your agent. Fault, short circuit or fire may occur if you continue to operate the unit under abnormal situation. ● Please contact your agent for maintenance. Improper self maintenance may cause electric shock and fire. ● Please contact your agent if you need to remove and reinstall the unit. Electric shock or fire may occur if you remove and reinstall the unit yourself improperly. 	
----------------------	---	--

PRECAUTIONS DURING OPERATION

▲ W A R N I N G	<ul style="list-style-type: none"> ● Avoid an extended period of direct air flow for your health. 	
	<ul style="list-style-type: none"> ● Do not put objects like thin rods into the panel of blower and suction side because the high-speed fan inside may cause danger. 	
	<ul style="list-style-type: none"> ● Do not use any conductor as fuse wire, this could cause fatal accident. 	
	<ul style="list-style-type: none"> ● During thunder storm, disconnect and turn off the circuit breaker. 	
	<ul style="list-style-type: none"> ● The product shall be operated under the manufacturer specification and not for any other intended use. 	
	<ul style="list-style-type: none"> ● Do not attempt to operate the unit with wet hands, this could cause fatal accident. 	
	<ul style="list-style-type: none"> ● When operating the unit with burning equipments, regularly ventilate the room to avoid oxygen insufficiency. 	
	<ul style="list-style-type: none"> ● Do not direct the cool air coming out from the air-conditioner panel to face household heating apparatus as this may affect the working of apparatus such as the electric kettle, oven etc. 	
	<ul style="list-style-type: none"> ● Please ensure that unit mounting frame is always stable, firm and without defect. If not, the unit may collapse and cause danger. 	
	<ul style="list-style-type: none"> ● Do not splash or direct water to the body of the unit when cleaning it as this may cause short circuit. 	
	<ul style="list-style-type: none"> ● Do not place plants directly under the air flow as it is bad for the plants. 	
	<ul style="list-style-type: none"> ● Please switch off the unit and turn off the circuit breaker during cleaning, the high-speed fan inside the unit may cause danger. 	
	<ul style="list-style-type: none"> ● Turn off the circuit breaker if the unit is not be operated for a long period. 	
<ul style="list-style-type: none"> ● Do not climb on the unit or put objects on it. 		
<ul style="list-style-type: none"> ● Do not put water container (like vase) on the unit to avoid water dripping into the unit. Dripping water will damage the insulator inside the unit and causes short circuit. 		
<ul style="list-style-type: none"> ● When operating the unit with the door and windows opened, and with the air deflector facing down for a long period of time, water will condensed on the air deflector and drips down occasionally. This will wet your furniture. Therefore, do not operate under such condition for a long time. 		
<ul style="list-style-type: none"> ● If the amount of heat in the room is above the cooling capability of the unit (for example: more people entering the room, using heating equipments and etc.), the preset room temperature cannot be achieved. 		

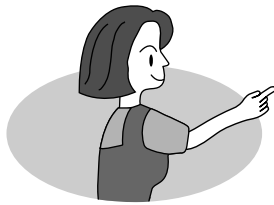

PARTS IDENTIFICATION AND OPERATIONS

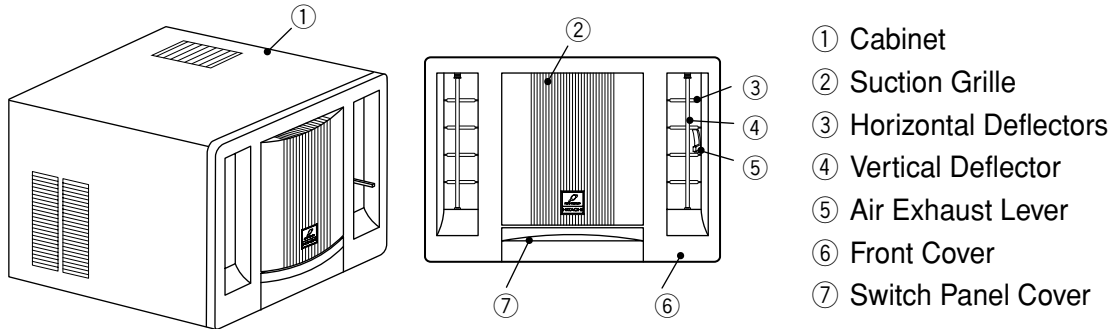

- ① Cabinet
- ② Suction Grille
- ③ Horizontal Deflectors
- ④ Vertical Deflector
- ⑤ Air Exhaust Lever
- ⑥ Front Cover
- ⑦ Switch Panel Cover

Model	Width	Height	Depth
RA-08JF1 RA-10JF1	18 ¹ / ₂ " , 470mm	13 ⁹ / ₁₆ " , 345mm	23 ⁷ / ₂₀ " , 610mm

CONTROL PANEL

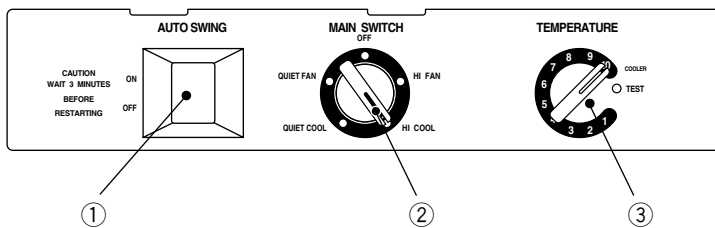

- ① Auto Swing Switch
- ② Operation Mode Selector Dial
- ③ Thermostat Dial

AUTO SWING

- When the AUTO SWING switch is turned to "ON" position, the vertical deflectors automatically oscillate right and left sweeping the cold air alternately to obtain comfortable cooling.
- The vertical deflectors may be stopped at any position when the AUTO SWING switch is turned "OFF".

OPERATION MODE SELECTOR DIAL

OFF	Stop the fan and cooling operation.
QUIET FAN	The air conditioner will perform fan operation only at low speed.
HI FAN	The air conditioner will perform fan operation only at high speed.
QUIET COOL	Cooling operation with low fan speed. This is recommended for sleeping comfort.
HI COOL	Cooling operation with high fan speed for maximum cooling power.

- The starting operation will occur an abnormal sound (turbo sound) which doesn't affect the operation.

THERMOSTAT DIAL

Setting the desired room temperature. Turn the dial further clockwise for cooler indoor temperature.

⚠ CAUTIONS

- The compressor operates continuously by setting the temperature dial to “TEST”. This setting is used for technician. If the unit is operated at this position, the heat exchanger may freeze and causing water leakage or other malfunction. Do not set to “TEST” for normal usage.
- When the compressor stops by turning the temperature dial counterclockwise in cooling operation, wait 3 minutes before turning it clockwise to restart it.

AIR DEFLECTORS

VERTICAL DEFLECTORS

Vertical deflectors at both sides of outlets can be set to either auto-swing or static position to direct discharge air rightward, leftward or forward direction.

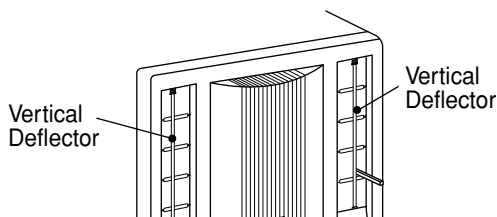

HORIZONTAL DEFLECTORS

Horizontal deflectors at both sides of the outlets can be set to direct discharge air upward, downward or forward direction.

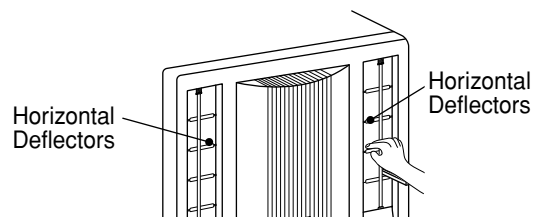

⚠ CAUTION

To avoid dew forming on the deflectors which eventually may drip to the floor, please do not adjust horizontal deflectors extremely downward position or vertical deflectors extremely leftward or rightward position during cool operation for a long time. Also, do not adjust the vertical deflectors position by hand or any other object.

AIR EXHAUST LEVER

Set the air exhaust lever to the OPEN (pull) position for air ventilation in the room. The air exhaust lever should normally be kept in CLOSE (push inward) position during cooling operation and in the case of typhoon.

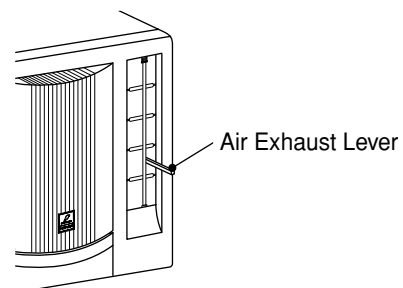

AIR CLEANING FILTER

ALWAYS STOP THE OPERATION BEFORE INSTALLING THE AIR CLEANING FILTER.

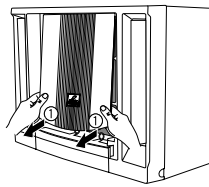

1. Open the suction grille

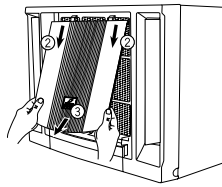

2. Remove the normal filter

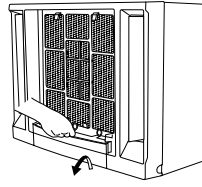

Air Cleaning Filter

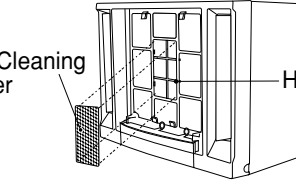

Hook

3. Install the air cleaning filter in the frame
4. Install back the normal filter and close the suction grille

AIR CLEANING FILTER IS WASHABLE AND REUSABLE UP TO 20 TIMES BY USING VACUUM CLEANER OR RINSE WITH RUNNING TAP WATER.

AIR CLEANING FILTER SHOULD BE CLEANED EVERY MONTH OR SOONER IF NOTICEABLE LOADING OCCURS. WHEN USE OVERTIME, IT MAY LOSE ITS DEODORIZING FUNCTION.

FOR MAXIMUM PERFORMANCE, IT IS RECOMMENDED TO REPLACE IT EVERY 3-6 MONTHS DEPENDING ON APPLICATION REQUIREMENT.

TYPE NUMBER FOR THIS AIR CLEANING FILTER IS <SPX-CFH8W>, PLEASE USE THIS NUMBER FOR ORDERING WHEN YOU WANT TO RENEW IT.

NOTES ON OPERATION

TEMPERATURE AND HUMIDITY

Avoid to use the room air conditioner for cooling operation when the outside temperature is below 21°C (70°F). Recommended operation humidity should be below 80%. Continuous long operation at over 80% humidity (indoor) will cause some dew to form on the outlet grille of the unit.

NOISE

In a quiet environment or stopping and starting operation, phenomena like flowing noise of refrigerant in the refrigerating cycle and rubbing noise from the fan casing may occasionally occur, but this is normal for the operation.

Water will condense on the evaporator coil and collected in the bottom tray, it is picked up by the condenser fan and blown onto the condenser coil, this creates a "splashing" noise which is normal.

ODOR

The odor will possibly be emitted from the room air conditioner especially at the starting of operation and in a high humidity condition. This is not abnormal phenomena because of the various kind of odors emitted by smoke, food stuffs, cosmetics and others which may stick to the room air conditioner. So, please clean the air filter and evaporator at the beginning of long no operation period to reduce the odor.

THE IDEAL WAYS OF OPERATION

Suitable Room Temperature



Warning

Freezing temperature is bad for health and a waste of electric power.

Install Curtain or Blinds



It is possible to reduce heat entering the room through windows.

Ventilation



Caution

Do not close the room for a long period of time. Occasionally open the door and windows to allow the entrance of fresh air.



Do Not Forget To Clean The Air Filter

Dusty air filter will reduce the air volume and the cooling efficiency. To prevent from wasting electric energy, please clean the filter every 2 weeks.



Please Adjust Suitable Temperature For Baby And Children

Please pay attention to the room temperature and air flow direction when operating the unit for baby, children and old folks who have difficulty in movement.



FOR USER'S INFORMATION

The Air Conditioner And The Heat Source In The Room



Caution

If the amount of heat in the room is above the cooling capability of the air conditioner (for example: more people entering the room, using heating equipments and etc.), the preset room temperature cannot be achieved.

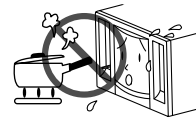

When Lightning Occurs



Warning

To protect the whole unit during lightning, please stop operating the unit and remove the plug from the socket.

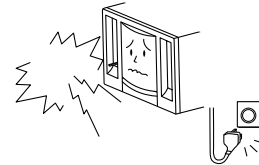



MAINTENANCE

⚠ CAUTION

ALWAYS TURN OFF AND UNPLUG BEFORE ANY CLEANING OR MAINTENANCE TO ENSURE SAFETY.

AIR FILTER

If the air filter is clogged with dust, the air flow volume will decrease and resulting in poor cooling performance, and increased operating noise. Be sure to clean the filter about every 20 days.

- ① Remove the suction grille by pulling at both bottom corner and then lift it up slightly before pull downward to unhook the suction grille.
- ② Lift and unhook the bottom of the air filter and remove it.
- ③ Remove dust from the filter by using a vacuum cleaner. If the filter is very dirty, wash it with detergent and rinse properly with water. Dry it with soft cloth and do not expose it to heat or under direct sunlight.
- ④ Install the filter by fitting the top hooks and then hook the bottom of the filter.
- ⑤ Attach the suction grille back to its place by hooking at the top side to the front cover, then gently push at both bottom corner.

SUCTION GRILLE

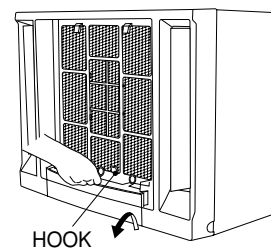
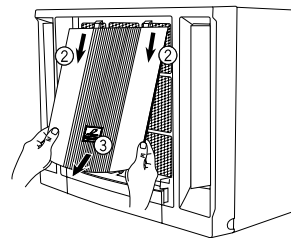
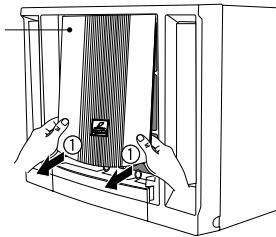

HOOK

⚠ CAUTION

- Do not use hot water above 40°C for cleaning the filter.
- Do not operate the air conditioner with the filter removed.

FRONT COVER AND SUCTION GRILLE

Clean the front cover and suction grille with a soft dry cloth. When it is excessively dirty, wipe it with a soft cloth dampened with mild soap, then wipe it again thoroughly with a soft dry cloth.

The suction grille can also be removed and be washed with water and mild soap. Remove the suction grille in the following manner.

- ① Pull the suction grille at both bottom corner and released it.
- ② Lift up the suction grille slightly.
- ③ Remove the suction grille by pulling downward to release it from the hook hole located at the top side.

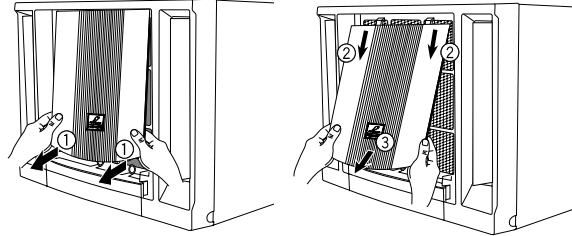

⚠ CAUTION

Never use hot water above 50°C, erosive chemicals or brush to clean the front cover and suction grille because they will damage the plastic surface.

BEFORE ASKING FOR SERVICE

Check the following items before asking for service. If the malfunction persists, please contact service centre.

Symptom	Cause
Does not operate at all	<ol style="list-style-type: none"> ① Is the power cord loosened or unplugged? ② Is the fuse blown out or the circuit breaker tripped? ③ Is the voltage normal? ④ Is the main switch set to "OFF" position?
Poor cooling performance	<ol style="list-style-type: none"> ① Is the air filter covered with heavy dust? Clean the filter and replace it. ② Is the temperature setting correctly? ③ Is the sunlight fall directly in the air conditioner? ④ Is the air flow on the rear side (outdoor) blocked? Leave a space of 900 mm (3 feet) behind the rear side of air conditioner. ⑤ The doors or windows may be opened widely or there are other sources of heat in the room. ⑥ Is the ventilation damper opened?

⚠ CAUTIONS

IF THE POWER SUPPLY CORD IS DAMAGED, IT MUST BE REPLACED BY THE ONE SPECIALLY PREPARED AND ONLY AVAILABLE FROM THE MANUFACTURER OR ITS SERVICE AGENT.

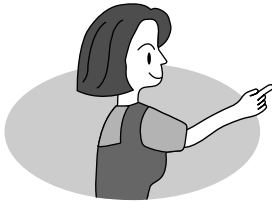

INSTALLATION INSTRUCTIONS

REMOVE ALL THE SHIPPING PARTS BEFORE INSTALLATION AND CONSULT YOUR DEALER CONCERNING INSTALLATION REQUIREMENTS.

LOCATION

- Select a location that can support the weight of the air conditioner and will not cause increased operating noise and vibration.
- Select a location where direct sunlight does not fall on your air conditioner.
- Select a good location for efficient air circulation.
- Select a place where there is no obstacles near the air inlet and outlet.

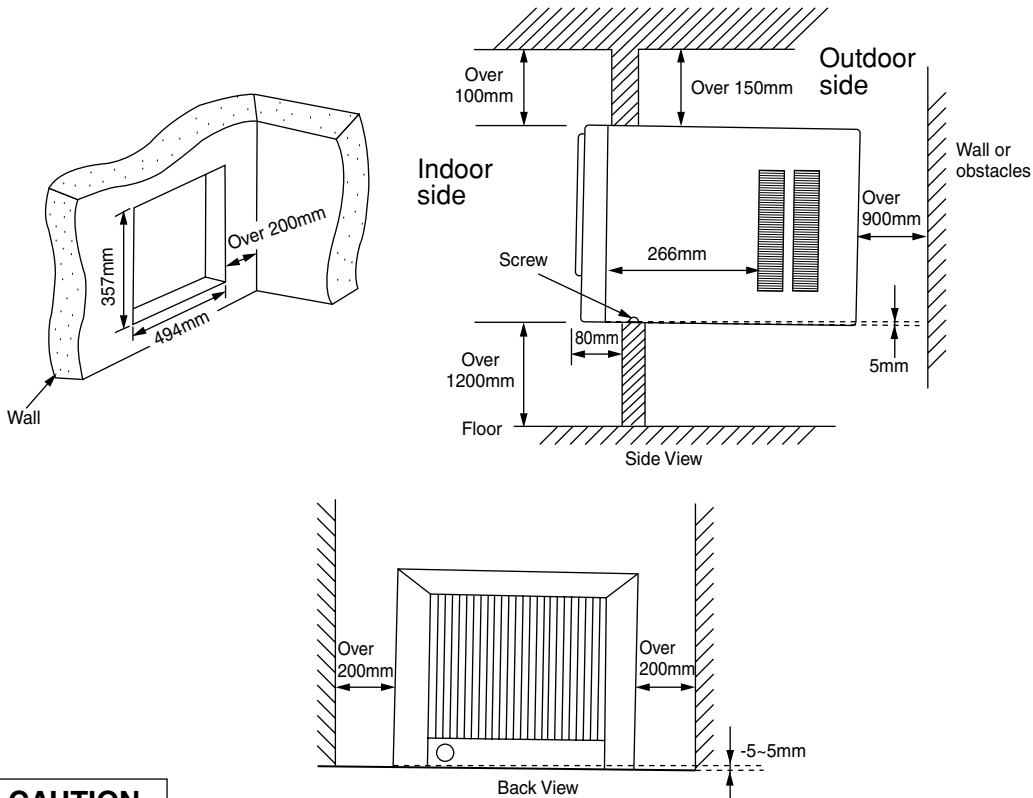

CAUTION

- The installation material must be fully strong against corrosion, especially in case the air conditioner to be installed near the sea or hot spring.
- Do not install air conditioner in the places where there is a possibility of inflammable gas leaks.
- Secure tightly the cabinet with screws. Otherwise there may be danger of the air conditioner dropping.
- Please keep the recommended installation dimensions. Otherwise waterdrops may occur.

POWER SOURCE

- Check the capacity of wiring and power outlet. The power outlet should be used exclusively for the air conditioner. Do not use it with other appliances. Any wiring must follow the national wiring regulation.
- Ground the air conditioner to prevent danger of electric shock.
- Connect the air conditioner with power source securely.
- Use a fuse as below:

RA-08JF1 RA-10JF1	15A time delay fuse
----------------------	---------------------

Voltage rating	50Hz 220-240V
Operatable Voltage range	50Hz 198-264V

⚠ CAUTION

WARNING – THIS APPLIANCE MUST BE EARTHED.

REMOVE THE FRONT COVER

Remove the front cover in the following manner.

- ① Pull the suction grille at both bottom corner and release it.
- ② Remove the air filter.
- ③ Remove two screws which secure the front cover.
- ④ Remove the front cover from lower side.

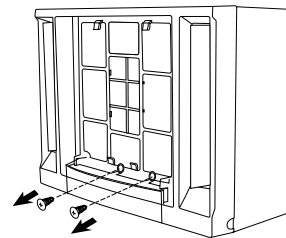
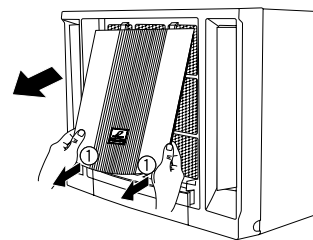

SLIDE OUT OF UNIT

- ① Remove the four screws which fasten the base pan to the cabinet at the side and back.
- ② Slide out the unit by pulling the handles.

After slide in the unit, please install the sealer between the base pan and cabinet to prevent from entering rain water in case of typhoon. Fasten the unit to cabinet at the side with the screw, then refit the front cover.

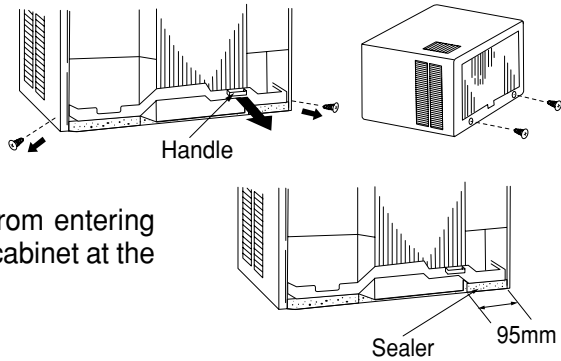

STOPPER

When the screws at the both side of the cabinet cannot be fasten, please use the stopper (a "L" shape metal plate that is provided in the plastic bag with the sealer) to fix the cabinet and the base pan located at in front of the unit.

The steps to fix the stopper are as below:

- ① Remove the screw which fasten the plastic band and electrical box to the base pan.
- ② Fix and align the stopper into the rectangular hole of the cabinet.
- ③ Fasten back the screw to fix plastic band, stopper and electrical box to the base pan.

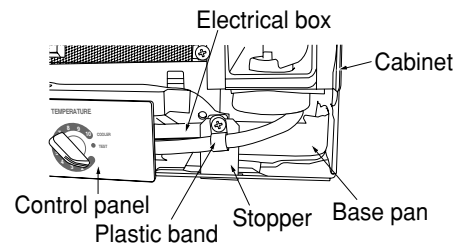

POWER CORD ARRANGEMENT

If power cord is withdrawn from left side of unit, please arrange the power cord as in figure after installing the front cover.

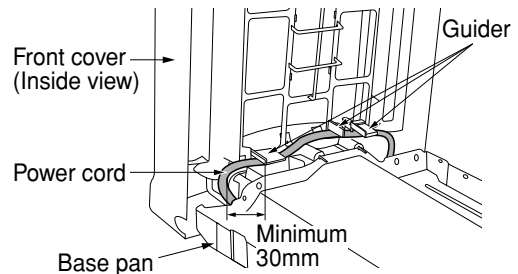

DRAIN PAN

CONDENSED WATER DRAINAGE

This air conditioner employs a "turbo fan splashing ring" which is designed to splash the condensed water on the condenser surface for maximum cooling efficiency, thus producing a splashing sound.

If you are uncomfortable with the sound, you can install an outside drainage by using the following procedure which may, however cause a small loss of performance.

- ① Remove the rubber plug from the base pan.
- ② Install the drain pan by using 2 pieces of screws (provided) at the cabinet.
- ③ Connect the drain pan with the drain hose. (Drain hose or tubing can be purchase locally to satisfy your particular needs. Drain hose inner diameter size should be around $\phi 13\text{mm}$ or $1/2$ inch.)
- ④ Slide the air conditioner unit back into the cabinet.

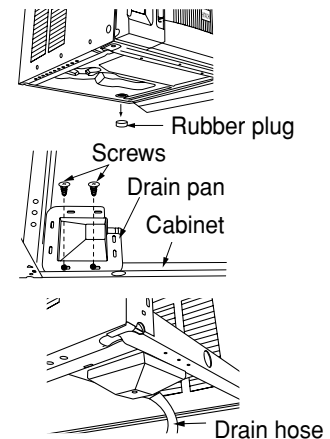

CAUTION

BEFORE START OPERATION OF AUTO SWING FUNCTION, PLEASE TURN THE RIGHT VERTICAL DEFLECTOR TO THE MOST RIGHTWARD AND SWITCH ON THE AUTO SWING SWITCH TO CHECK THE VERTICAL DEFLECTOR MOVEMENT.

THE ABNORMAL SOUND WILL OCCUR DURING VERTICAL DEFLECTOR ADJUSTMENT AND IT DOESN'T AFFECT THE AUTO-SWING OPERATION.

DURING USAGE IF THE VERTICAL DEFLECTOR CHANGES ANGLE THEN PLEASE DO THE ABOVE SETTING AGAIN.

WHEN RAINING, RAIN WATER WILL ENTER THE OUTDOOR UNIT. WHEN THE AIR CONDITIONER STARTS OPERATING (AFTER RAINING) FOR ABOUT 10 MINUTES, THERE WILL BE AN ABNORMAL NOISE FROM OUTDOOR UNIT. THIS WILL NOT EFFECT THE PERFORMANCE OR LIABILITY OF THE AIR CONDITIONER.

INSTALLATION WORK INSPECTION CHECK LIST

Item No.	Check Item	Initials
1	Have you removed the shipping parts? Please check the caution sheet which is attached at front cover.	
2	Is the incline of room air conditioner regarding front and rear, right and left all right after installation?	
3	Is the strength of installation sufficient?	
4	Have you grounded your room air conditioner?	
5	Have you fastened the unit to the cabinet?	
6	Have you done a test operation, and are there any abnormal phenomena?	

MEMO

.....

.....

.....

.....

.....

.....



安全上應特別注意之事項

- 使用前，請詳細閱讀「安全上的注意事項」，以正確的使用機體。
- 在所示注意事項的“▲警告”、“▲注意”需特別加以注意。“警告”欄中記載之事項，表示處理錯誤時，可能會造成死亡或重傷，而“注意”欄中記載之事項，因狀況也可能造成重大之後果，所以請務必遵守，以維護安全。
- 另外圖像中的“⊘”表示禁止事項。
- 閱讀完後，請務必妥善保管。

安裝上的注意事項

▲警告	<ul style="list-style-type: none"> ● 安裝時，請委託經銷商或專門技術人員安裝。自己安裝可能會造成漏水、觸電及火災。
▲注意	<ul style="list-style-type: none"> ● 請使用接地線。地線請勿安裝在瓦斯管、水管、避雷針、電話之地線等場所。 ● 依設置場所狀況，有必要安裝漏電斷電器。如沒有安裝漏電斷電器時，會有觸電的危險。 ● 不可安裝於有可燃氣體的場所，因為萬一氣體泄漏在機體周圍的話，可能會發生火災。 ● 安裝排水管時，請確認水可否順利的流出。（排水管型）

搬移或修理時的注意事項

▲警告	<ul style="list-style-type: none"> ● 異常時（有焦味等），請停止運轉後把斷電器關閉，並通知經銷服務人員。有異常而照舊連續運轉的話，會造成故障、觸電、火災等。 ● 維修時，請直接向經銷服務人員接洽。自己修理不完全的話，會有觸電、火災的危險。 ● 機體要移動重新再設置時，請直接向經銷服務人員接洽。自己移動機體，重新再設置時，若安裝不安全的話，就會有觸電、火災的危險。
------------	---

使用上的注意事項

▲警告	<ul style="list-style-type: none"> ● 身體請勿長時間直接對著冷氣，以免妨礙健康。
	<ul style="list-style-type: none"> ● 請勿將細棒等物品插入吹出口及吸入口，由於風扇在高速運轉，易造成危險。
	<ul style="list-style-type: none"> ● 請勿以金屬或銅線當作保險絲，以免發生故障或火災。
	<ul style="list-style-type: none"> ● 有打雷之可能時，為了保護機械，請停止運轉，並把斷電器關閉，以避免故障發生。
	<ul style="list-style-type: none"> ● 本機請使用在以一般家庭的人為對象的場所，請勿使用在保存食品、動植物、精密機器、美術品、醫藥品等特殊場所。
	<ul style="list-style-type: none"> ● 請不要用濕手來操作開關，以免觸電。
	<ul style="list-style-type: none"> ● 與燃燒器具一起運轉時，請常換氣，否則會有氧氣不足的情形。
	<ul style="list-style-type: none"> ● 本機所吹出來的風，請不要直接吹在燃燒器具上，否則，會使燃燒器具燃燒不完全。
	<ul style="list-style-type: none"> ● 長期使用的安裝材料請隨時注意其是否穩固，不可有損傷的情形。否則機體可能會落下造成危險。
	<ul style="list-style-type: none"> ● 清洗機體時，請絕對避免用水潑機體，因會有漏電的危險。
	<ul style="list-style-type: none"> ● 動植物請不要放置在風向直接吹到的場所，否則會對動植物有不良的影響。
	<ul style="list-style-type: none"> ● 清潔機體時，請停止運轉並把斷電器關閉。因為機體內部的風扇正以高速運轉，會造成傷害。
	<ul style="list-style-type: none"> ● 長時間不運轉時，為了安全起見，請把斷電器關閉。
	<ul style="list-style-type: none"> ● 請勿爬上機體，物品也不要放在機體上面。
	<ul style="list-style-type: none"> ● 機體上請不要放有水的容器（如花瓶），以免傾倒流入機體內部，會使機體內部電氣絕緣劣化，產生觸電的危險。 ● 冷氣運轉時，窗和門在開放的狀態下，風向板向下時，都請不要長時間運轉，否則上下風向板會結露，有時會滴下來，而使傢俱弄濕。 ● 房間如果有超過冷氣能力的熱源（如房間有多人進入，使用熱器具等），將無法達到所設定室溫。

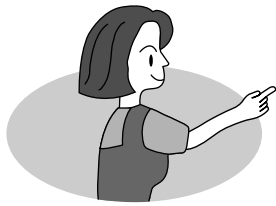

部件名稱及操作

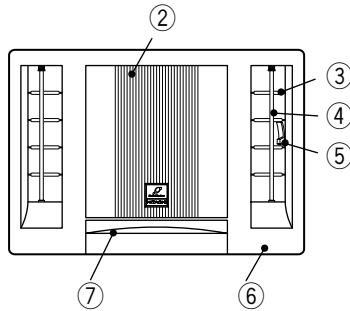
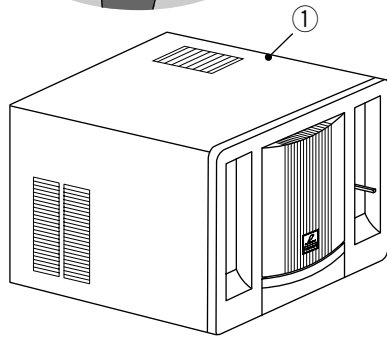

- ① 機箱
- ② 吸氣柵
- ③ 水平風向調整板
- ④ 垂直風向調整板
- ⑤ 排氣桿
- ⑥ 前面蓋
- ⑦ 控制板蓋

型號	寬度	高度	長度
RA-08JF1 RA-10JF1	18 ¹ / ₂ " , 470mm	13 ⁹ / ₁₆ " , 345mm	23 ⁷ / ₂₀ " , 610mm

控制板

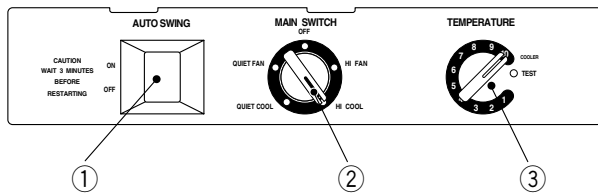

- ① 自動搖擺鈕
- ② 操作選擇鈕
- ③ 定溫器鈕

自動搖擺

- 當自動搖擺鈕被調到 ' ON ' 時，垂直調整板將自動游移左右則輪流排掃出舒適的涼風。
- 只要自動搖擺鈕被調到 ' OFF ' 時，垂直調整板將會停留在任何位置。

操作模式選擇鈕

OFF	停止風扇及冷卻操作。
QUIET FAN	冷氣機將只在低速度的風扇操作。
HI FAN	冷氣機將只在高速度的風扇操作。
QUIET COOL	在低風扇速度下進行冷卻操作。這特別供舒適安眠時使用。
HI COOL	在高風扇速度下進行冷卻操作以便達到最大冷卻功能。

- 開始操作時會發出異聲(超速聲)但不會影響操作功能。

定溫器鈕

設定所希望的室內溫度。越是順時針旋轉此開關，室內將越涼爽。

⚠ 注意

- 如把此開關設定於“TEST”(試驗)的位置，壓縮機將連續地操作。此設定是供服務人員使用，若冷氣機在此設定下操作，蒸發器可能結冰而造成水滴或其他故障。對於日常的使用請不要把定溫器鈕設於“TEST”的位置。
- 冷卻操作中如向反時針方向轉動定溫器鈕而停止壓縮機時，必須等候3分鐘後才可以將定溫器鈕向順時針方向旋轉以開動壓縮機。

風向調整板

垂直風向調整板

垂直調整板兩邊的吹出口可調置於自動掃蕩或靜止狀態，將風向設於右、左或直面排風。

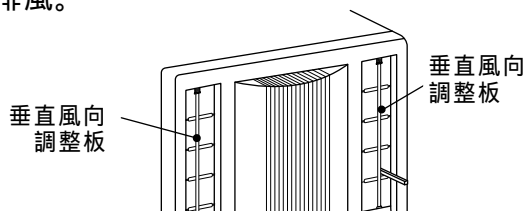

水平風向調整板

水平調整板兩邊的吹出口可將風向設於上、下或直面排風。

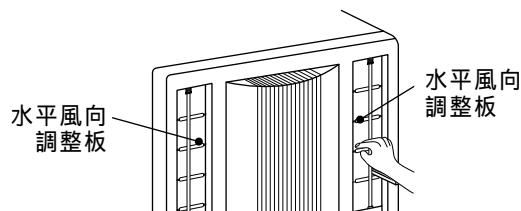

⚠ 注意

為了避免露水滴在調整板上，請勿長時間在冷卻操作下把水平調整板調得太低或者把垂直調整板向左右極端擺動。況且，不能用手或其他物件去調垂直風向調整板的位置。

排氣桿

把排氣桿設在開（拉出），以便循環室內空氣。在冷卻操作及颱風時，排氣桿應設在（推進）關。

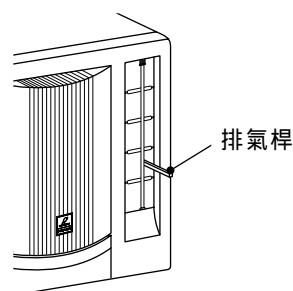

空氣濾清器

安裝濾清器前必須要停止操作。

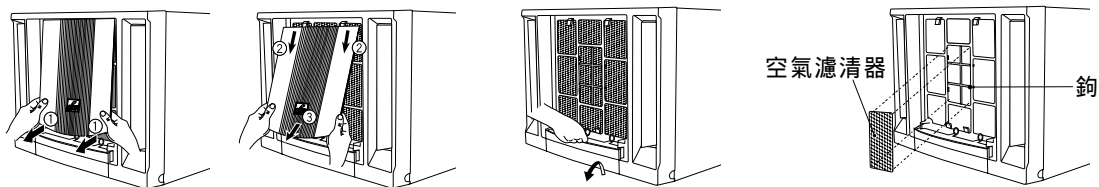

1. 打開吸氣柵

2. 拿掉普通隔濾網

3. 安裝空氣濾清器在框架內
4. 裝回普通隔濾網及關上吸氣柵

用吸塵機或清水將空氣濾清器清洗，它可被再用多達二十次。

空氣濾清器應每個月或當灰塵累積時清洗。如果使用過期，僅有可能失去除臭功能。

每 3 - 6 個月更換濾清器一次或視施用需求而定以達到最佳功效。

空氣濾清器型號為 <SPX-CFH8W>，更換時請使用此型號向經銷店購買。

操作注意

溫度及濕度

避免在室外氣溫低於攝氏 21 度（華氏 70 度）時，使用此冷氣機作為冷卻操作。建議操作濕度為 80% 以下，長時間在 80%（室內）濕度以上操作，將造成少許露水在出風口柵格形成。

噪音

在穩靜操作期間，或當停止運轉時，有時會聽見冷凍劑流動的微小聲音和風扇罩受熱或受冷時所發出的微小摩擦聲。但這些都是正常的現象。

在蒸發器上凝結的水將收集在底盤裡，冷凝器的風扇將水帶上並噴向冷凝器。這將造成“噴射”的正常水聲。

異味

冷氣機有時會發出異味，特別是在開機初時及高潮濕的環境下，但這並非不正常的現象，而是因為煙，食物，化妝品等所發出的異味附著在上面的緣故。所以在長期停用後而再想使用時，最好清理空氣隔濾網和蒸發器部份以減少臭味。

最佳的使用方法

室溫設定要適當



警告
過冷對健康不好
且會浪費電力。

裝置窗簾或百葉窗

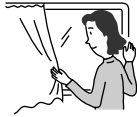

可隔絕從窗戶進來的熱源。

換氣

注意
房間不要關閉太久，請偶爾
打開窗戶，換新鮮空氣。



濾網請不要忘記清洗

濾網的網目塞住會影響風量，減弱冷氣效果，為了不浪費電力，請每隔 2 週務必清洗一次。



為了嬰兒及小孩， 請注意室溫調節

行動不便的嬰兒、小孩、老年人等使用冷氣機時，請注意室內溫度及風向的調節。



顧客須知

冷氣和房間的熱源

注意
房間如果有超過冷氣能力的熱源（如房間有多人進入，使用熱器具等），將無法達到所設定的室溫。

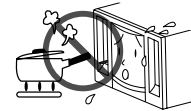

有打雷之虞時

警告
有打雷之虞時，為了保護機械而需停止運轉，請把電源插頭拔起來。

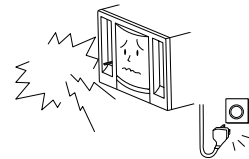



維修保養

▲ 注意

清掃之前請務必關掉操作開關及拔掉電源插頭，以確保安全。

空氣隔濾網

若空氣隔濾網沾滿灰塵，吹出風量將減少而造成冷卻功能減低，及增大操作噪音。請確保每 20 天清理隔濾網一次。

- ① 在吸氣柵兩邊的下端一拉，然後稍微提起吸氣柵直至將吸氣柵取出。
- ② 提起空氣隔濾網下端後把它拿出。
- ③ 用吸塵機清除網上的灰塵。若隔濾網太過骯髒，用少許清潔劑清洗及用水完全洗淨，用柔軟布弄乾，不可接觸高溫或受陽光直曬。
- ④ 把隔濾網裝回在上端及下端的架鉤上。
- ⑤ 把吸氣柵上端向前面蓋繫上，再輕輕把吸氣柵下端左右一按以關上吸氣柵。

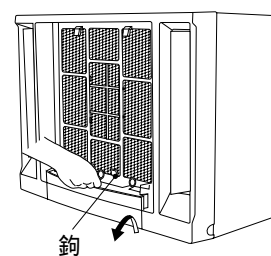
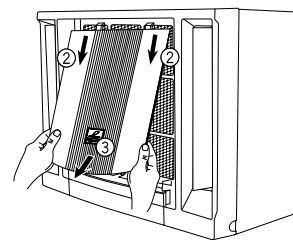
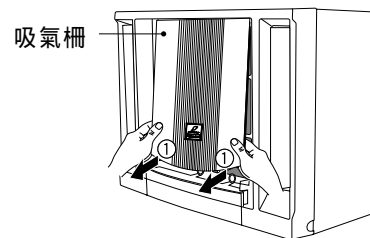

▲ 注意

- 不可用 40℃ 以上的水來清洗。
- 在隔濾網拿掉下，不可操作冷氣機。

前面蓋和吸氣柵

請用柔軟乾布擦抹前面蓋。如果它過度骯髒，請用沾以溫水及中性洗潔劑的軟布擦抹，然後用柔軟的乾布完全抹乾。

吸氣柵也可拆出來清洗。請按照下列方法拆出吸氣柵。

- ① 在吸氣柵下端左右角一拉後放開。
- ② 稍微提起吸氣柵。
- ③ 稍微在吸氣柵上端的架鉤向內一推後拆出它。

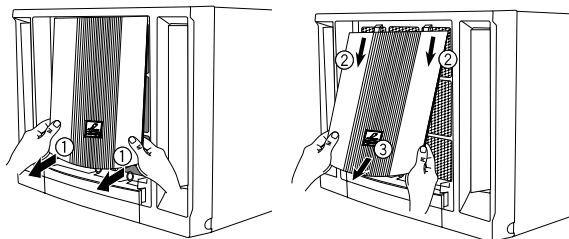

⚠ 注意

請勿用 50°C 以上的熱水、化學劑或刷子來清洗前面蓋及吸氣柵，因為它們將會損壞塑膠表面。

要求服務之前

在要求修理或服務之前，請先檢查下列各點。如果故障依舊，則請洽詢維修服務中心。

問題	原因
無法運行	<ol style="list-style-type: none">① 電源軟線是否鬆了或插頭沒插好？② 保險絲是否熔斷或斷電器是否跳擊？③ 電壓是否正常？④ 電源開關是否設在“OFF”的位置？
冷卻效果不佳	<ol style="list-style-type: none">① 空氣隔濾網是否太髒？ 清洗隔濾網後裝回它。② 設定溫度是否適當？③ 陽光是否直射在冷凝器上？④ 室外的空氣流通是否受阻？ 請保留 900mm (3 尺) 的空間在冷氣機的後部。⑤ 房間或窗口是否開著或是否室內有其他熱源？⑥ 排氣蓋是否開著？

⚠ 注意

如果電源軟線損壞，必須使用由製造商或其服務店所特別預備及提供之軟線。



安裝方法

安裝前請拆除裝運用的部件及向經銷店諮詢有關安裝的需要。

地點

- 選擇一個能夠承受冷氣機的重量且不會增加操作噪音和震動的地點。
- 選擇一個沒有陽光直射在冷氣機的位置，建議地點是北、東面。
- 選擇一個通風良好的位置以增加冷氣效率。
- 選擇一個在空氣吹出口或吸入口附近沒有遮擋物的地點。

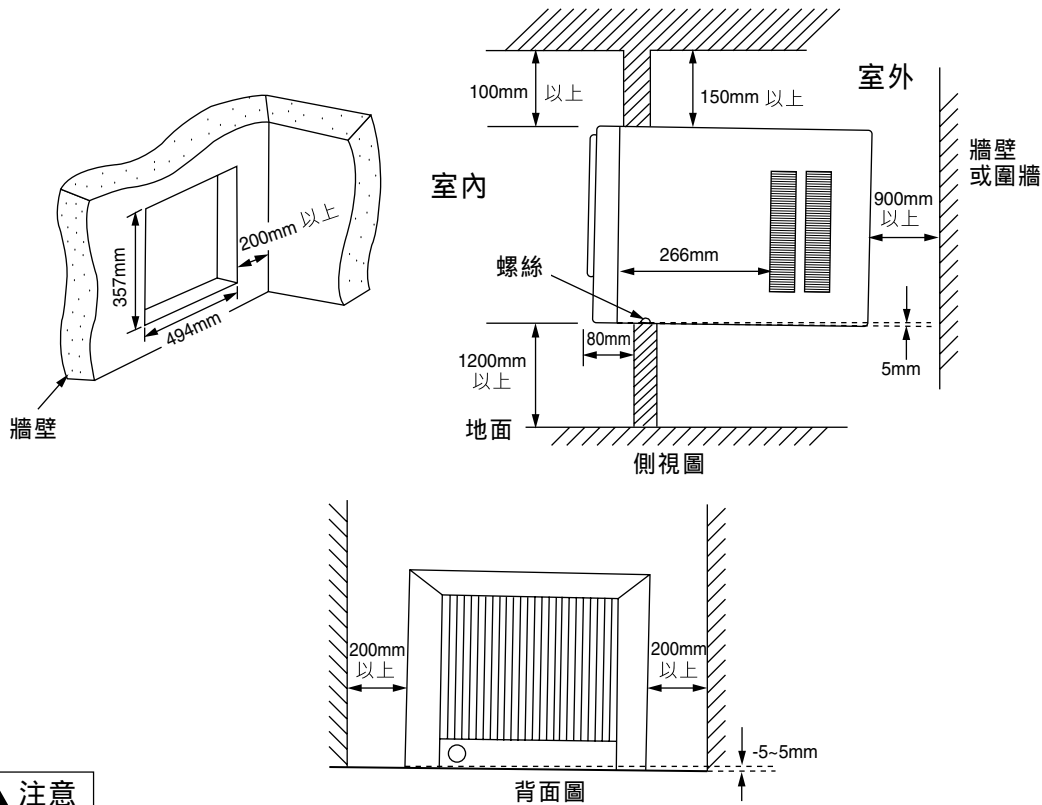

注意

- 安裝用部件應是高耐蝕性材料，特別是當冷氣機安裝在靠近海邊或溫泉附近時。
- 會漏出可燃性氣體的地方切勿安裝冷氣機。
- 用螺絲將機箱鎖緊。否則可能有冷氣機跌下的危險。
- 請確保按照所提供的尺寸來安裝。否則可能發生滴水現象。

電源

- 請檢查電線及插座的電流容量，插座應只供冷氣機專用，不可與其他家庭電器共用。一切電路必須依照有關地方標準電線路要求。
- 冷氣機應接地以避免發生觸電危險。
- 冷氣機電源插頭應緊牢地插入電源插座。
- 請使用以下的保險絲。

RA-08JF1 RA-10JF1	15A 時間延遲保險絲
----------------------	-------------

定額電壓	50Hz 220-240V
適用電壓範圍	50Hz 198-264V

⚠ 注意

注意：本冷氣機必須接地線。

前面蓋取出方法

請按照下列方法拆出前面蓋。

- ① 在吸氣柵下端左右角一拉及放開。
- ② 取出隔濾網。
- ③ 拆出兩粒鎖住前面蓋的螺絲。
- ④ 從下端取出前面蓋。

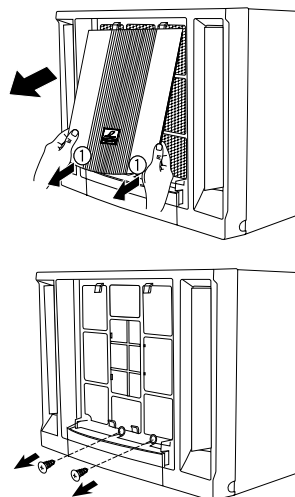

冷氣機拉出方法

- ① 拆出四粒在旁邊和後邊鎖住底盤及機箱的螺絲。
- ② 用把柄將機體拉出。

安置後請將密封材料填入底盤和機箱底板之間以防止遇到颱風時雨水滲入，然後用螺絲和夾具將機箱固定並裝回前面蓋。

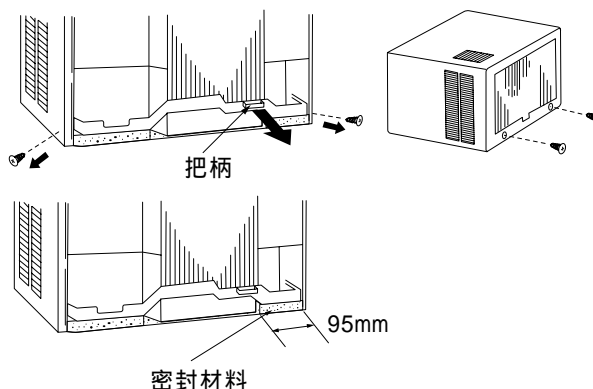

固定板

當無法在左右兩旁用螺絲鎖緊機箱時，請使用固定板（在塑膠袋裡與絕緣墊子一起附上的“L”形鐵片）將機箱與位置於冷氣機前面的底盤固定。

請依照以下步驟裝上固定板：

- ① 取出將塑膠環及電器箱鎖緊在底盤的螺絲。
- ② 將固定板安裝在機箱的長方形洞口內。
- ③ 用螺絲將塑膠環、固定板及電器箱再鎖緊在底盤。

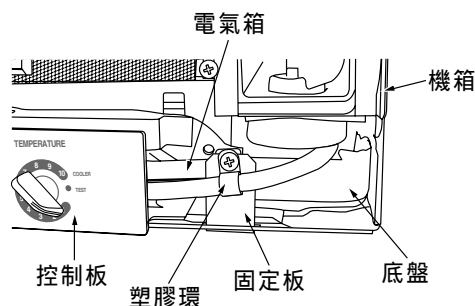

電源軟線排列

若要將電源軟線從機體左邊取出，請在裝回前面蓋後請依照右圖把電源軟線排好。

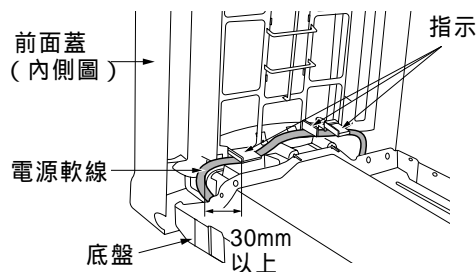

排水盤

結露排水管

這冷氣機運用“快速扇噴射環”專為潑結露在結露器以達到最高冷卻效率所設計，因此而發出潑水聲。

如果潑水聲讓你感到不適，請依照以下步驟利用戶外排水方式，但效率將會減低。

- ① 把底盤的膠塞子除去。
- ② 用兩枚螺絲（供給）把排水盤鎖在機箱上。
- ③ 將排水盤連接於排水管（排水管可在本地購買以滿足各要求。排水管內徑應 13mm 或半寸左右。）
- ④ 將機體置放回機箱裡。

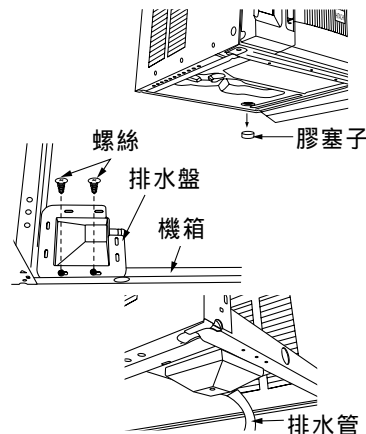

注意

在開始操作自動風擺功能前，請將右邊的垂直風向調整板轉到最右邊後開動風擺開關，以便檢查垂直風向板的轉動。

異聲會在調整垂直風向調整板時發出，但不會影響自動掃蕩功能。

在使用自動風擺時，如果垂直風向板角度有改變，請再用以上方法調整風向板。

下雨時，雨水會掉落在室外機內。當冷氣機開始操作（雨後）大約 10 分鐘內，將會有異聲從室外機發出。這並不會影響冷氣機的性能與操作。

安裝工作檢查表

項目	檢查項目	簽名（蓋章）
1	已拆卸了裝運用部件嗎？ 請校對前面蓋的注意表。	
2	安裝後冷氣機前後左右的高低是否正常？	
3	安裝強度是否足夠？	
4	冷氣機有否接地了？	
5	機器有否固定於機箱上？	
6	有否作了測試運轉？ 有否不正常現象？	

This indication is effective for Russian Federation only.

Настоящее положение действительно только для Российской Федерации.

“В соответствии со статьей 5, пунктом 2 “Закона о защите прав потребителей” для условий эксплуатации и в Российской Федерации на бытовой кондиционер устанавливается следующий срок – 7 лет с момента изготовления изделия.

Условия:

Настоящий срок службы распространяется на те элементы и части изделия, которые необходимы для его нормального функционирования при выполнении следующих условий:

- Изделие надлежащим образом установлено и используется в соответствии с инструкцией по эксплуатации и/или установке.
- Ремонт и техническое обслуживание изделия осуществляется в авторизованном сервисном центре.

Recommended temperature range for safety testing should be as below:

Cold side :	Dry bulb	21 - 35°C
	Wet bulb	15 - 23°C
Hot side :	Dry bulb	21 - 43°C
	Wet bulb	15 - 26°C



<737H0>

