

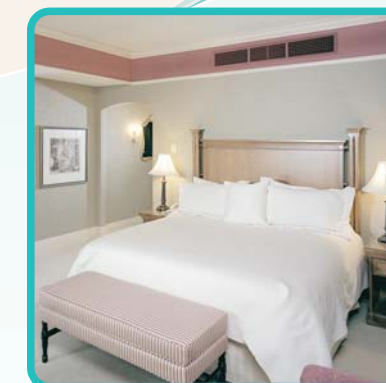

MULTIZONE

Multi-Split Type Air Conditioning Systems



HITACHI Air Conditioners must be installed and serviced by suitably qualified Electrical and Refrigeration trade persons.

Air Conditioning products depicted in this brochure are designed to perform only with refrigerant R410a.

Installation, routine maintenance and service guidelines are provided in product manuals for air conditioning specialists.

Cooling Indoor air temperature 27°C DB 19°C WB
Outdoor air temperature 35°C DB

Heating Indoor air temperature 20°C DB
Outdoor air temperature 7°C DB 6°C WB

Residential Warranty: **5 years** parts and labour.

ISO 9001 Approval Certificate



SIRIM

HITACHI AIR CONDITIONING PRODUCTS (M) SDN, BHD.
certified ISO 9001
Certificate number : AR0624
Certificate date : July, 1995

ISO 14001
Environmental Management Systems
Approval Certificate



HITACHI AIR CONDITIONING PRODUCTS (M) SDN, BHD.
certified ISO 14001
Certificate number : H003502047
Certificate date : April, 1997



Distributed by:

HITACHI AUSTRALIA LIMITED

ABN 34 075 381 332

Sales and Product Enquiries **1800 032 689**

www.hitachi.com.au



What is MULTIZONE system?

A MULTIZONE system is a split air conditioner that can combine one outdoor unit to multiple indoor. MULTIZONE provides flexibility in connecting indoor from various cooling capacities*, and different types of indoor units depending on the numbers of rooms, size and shape of the room and your preference.

Why MULTIZONE?

Multizone system allows one outdoor unit to combine with various indoor units, create more flexibility in installation and also save space. Therefore, multizone air conditioners are very suitable for small offices, hotels, shops and houses.

Note:
* Indoor connections are limited by the outdoor capacity range and numbers of possible connections.

MAIN KEY BENEFITS

- DC Inverter PAM control
- Wide selection of indoor unit types and capacities
- Compatibility between product ranges of outdoor and indoor units
- Highest COP and low noise
- Cooling available under -10°C ambient temperature
- Heating available under -15°C ambient temperature
- Auto restart by previous mode
- Washable carbon and anti-bacteria air purifying filter
- 24hr remote control timer
- R410a refrigerant

Extensive range and full indoor/outdoor compatibility

The Hitachi Multizone range was the world's first all DC Inverter Multisplit system with zone by zone cooling or heating for up to 6 rooms.

Hitachi DC twin-rotary compressor, together with award-winning DC inverter PAM technology, aid the achievement of a system power factor of almost 100%, thus providing unparalleled performance and efficiency. The all DC Inverter system ensures extremely sensitive and accurate temperature control through fuzzy logic and offers remarkably low sound levels.

The wide range of units have been designed for cooling operation under low temperatures, down to -10°C. This feature enables cooling to be obtained even in winter on buildings with high internal heat gains due to lighting, people and machines, particularly in areas such as shops and lecture rooms. The heating operation under low temperature, down to -15°C can also be performed.

The recent integration of Multizone employing R410A refrigerant provides a comprehensive selection of DC inverter PAM multi split systems, maintaining full compatibility of indoor unit throughout the range.

Multizone compatible indoor unit range caters for all requirements offering wall mounted, 60cm x 60cm cassettes, and in-the-ceiling duct units, designed to offer elegance and comfort to any application.

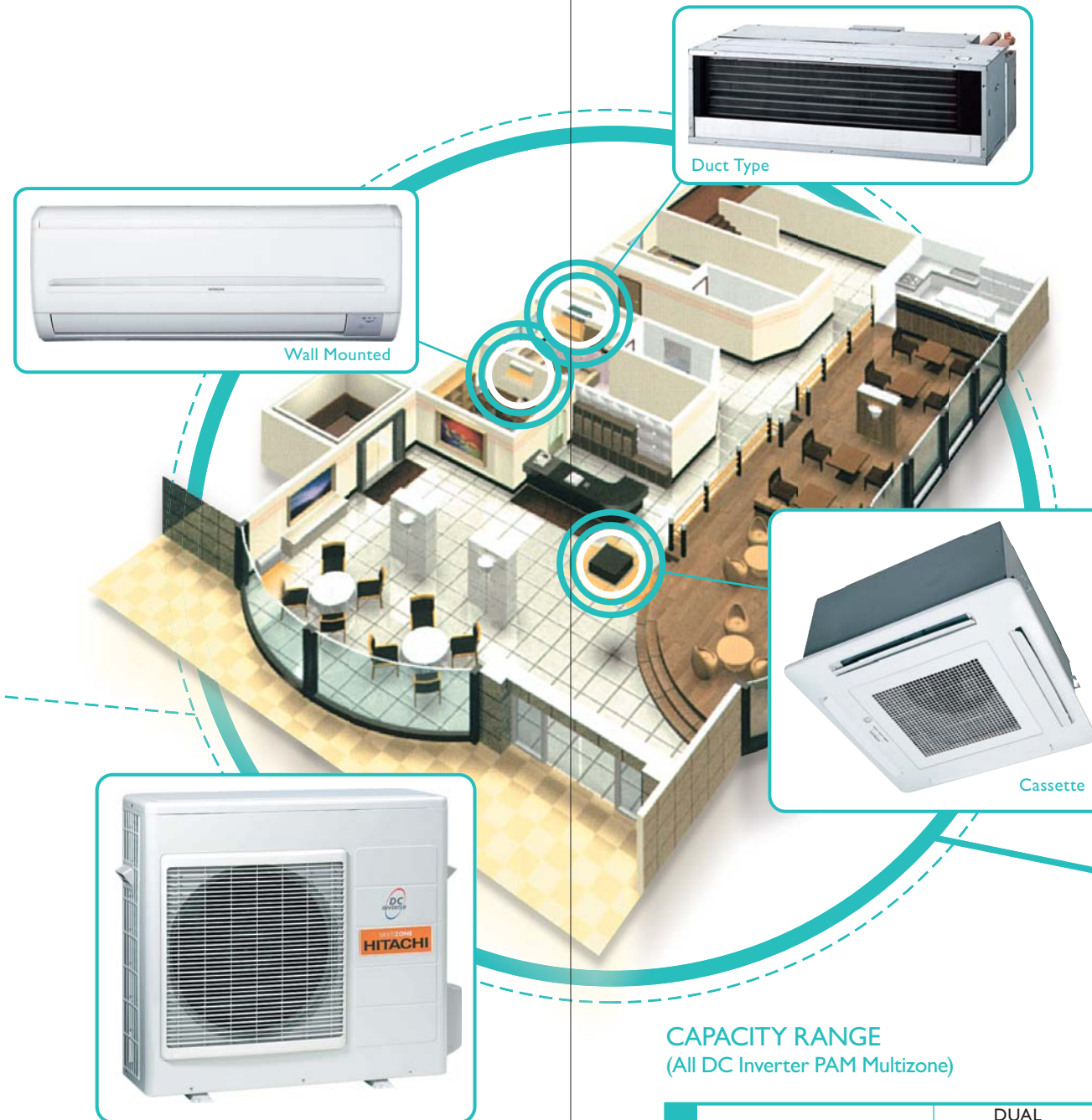

MULTIZONE

Comprehensive range/long pipe length and easy installation

You can choose and connect freely from different types of indoor and outdoor units depending on the number of rooms, width and shape of the room.

Multizone outdoor units can have a maximum chargeless piping length up to 70m when one outdoor unit is used with 6 indoor units in various locations. A maximum combination of indoor units can provide a wide selection of 6.5kW to 17.6kW.

ENERGY SAVING

SILENT OPERATION

SPACE SAVING

CAPACITY RANGE (All DC Inverter PAM Multizone)

OUTDOOR UNIT	DUAL (2 Rooms) Multizone		TRIPLE (3 Rooms) Multizone	QUADRUPLE (4 Rooms) Multizone		(5 Rooms) Multizone	(6 Rooms) Multizone
	40QHAI	55QHAI	65QHAI	72QHAI	80QHA	90QHAI	130QHAI
Nominal Capacity	4.0(C) 5.0(H)	4.0(C) 5.0(H)	6.3(C) / 7.5(H)	7.1(C) 8.6(H)	8.0(C) 11.0(H)	9.0(C) / 11.0(H)	12.6(C) / 14.4(H)
Total Combination	6.0	7.5	9.0 / 8.8	11.0 11.0	12.0 12.0	15.5	17.6
Capacity Max Pipe Length (m)	35	35	45	60	35+35	75	90

INDOOR UNIT	1.8	2.5	3.5	5.0	6.0	7.0
Capacity Range (kW)						
Wall (RAK)	●	●	●	●	●	●
4-Way Cassette (RAI)		●	●	●		
In-the-Ceiling (RAD)	●	●	●	●		

ENERGY SAVING



Power Saving

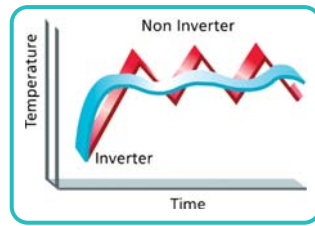

Inverter technology allows a room to reach the required temperature more rapidly and up to 30% more efficiently than Constant Speed Systems. Inverter technology also eliminates the incessant use of the stop-start mechanism often required to maintain consistent levels of temperature. Rather than starting the motor up and stopping it when the room temperature is reached, Hitachi inverters adjust (increase/decrease) the speed of the compressor to an energy saving mode in order to maintain the desired temperature.



High Energy Efficiency *

The "permanent magnet" motor featured in the DC compressor maintains magnetic current without the need for a constant source of electricity. This ensures the motor suffers less ambient energy loss, delivering 10% greater efficiency than equivalent AC inverters.

* Hitachi conforms to the 2002/31/EC Directive – 92/75/EEC "Energy Labelling Directive (ELD)", which is applicable from June 2004 on all air-conditioning products up to 12Kw cooling capacity. The DC inverter PAM technology helps us to achieve the "A" class, the highest level of energy efficiency which is clearly indicated on the standard labeling system.

Cooling		Heating	
3.20 < EER	More efficient	3.60 < COP	
3.20 ≥ EER ≥ 3.00	A	3.60 ≥ COP ≥ 3.40	
3.00 ≥ EER ≥ 2.80	B	3.40 ≥ COP ≥ 3.20	
2.80 ≥ EER ≥ 2.60	C	3.20 ≥ COP ≥ 2.80	
2.60 ≥ EER ≥ 2.70	D	2.80 ≥ COP ≥ 2.60	
2.40 ≥ EER ≥ 2.20	E	2.60 ≥ COP ≥ 2.40	
2.20 ≥ EER	F	2.40 ≥ COP	
	G		
	Lose efficient		

Annual energy consumption kWh in cooling mode
Cooling Output
Energy efficiency ration

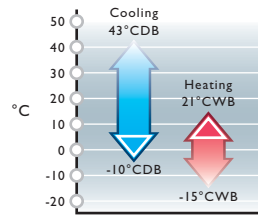

Extensive range of outside air conditions

Extensive air conditions can be handled by the Multizone System mini. The result - it extends the flexibility of installation space and climatic surroundings.



DC Twin Rotary Compressor

Our Multizone room air conditioning units have Hitachi's new twin rotary compressor which has even less vibration and even higher performance efficiency than conventional rotary compressors.

- Two rotary cylinders ensure well-balanced rotation unlike the conventional single rotary-type, thus greatly reducing any vibration noise.
- The compressor's operation is magnificently improved by the independent operation of the cylinders leading to greater efficiency and lower vibration.



PAM – Minimized Loss of Performance

Hitachi's PAM (Power Active Module) control system mirrors the current pulse waveform to avoid distortion and therefore achieve almost 100% power factor to enhance power efficiency. This cutting-edge device is employed in all Hitachi Multizone products for your comfort and energy saving for our environment. It ensures the efficient use of input power and minimizes loss to less than 1%. The PAM range boasts an industry leading COP of more than 4.0.

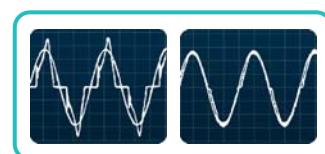
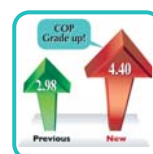

Comparison of Vibration

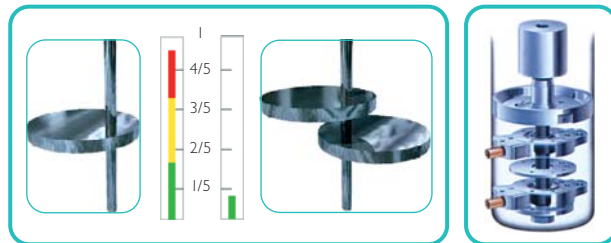

Conventional Single Rotary vs. New Twin-Rotary

Conventional inverter air conditioner

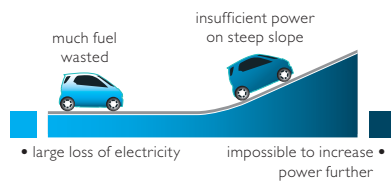

PAM air conditioner

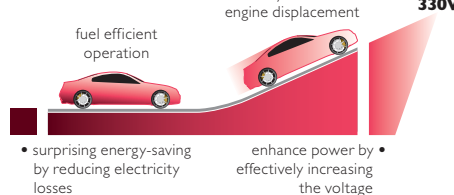

DC Fan Motor

The DC motor helps increase efficiency compared to conventional products using an AC motor. By controlling the speed of the fan, air blasts are reduced. Smoothly balanced operation can be achieved even against strong head winds of about 10m/s on the outer face of the outdoor unit.

Performance greatly improved, from low to high speed operation.

HIGH PERFORMANCE

Fan power is conserved should the performance is unnecessary depending on outside air temperature.

HIGH EFFICIENCY

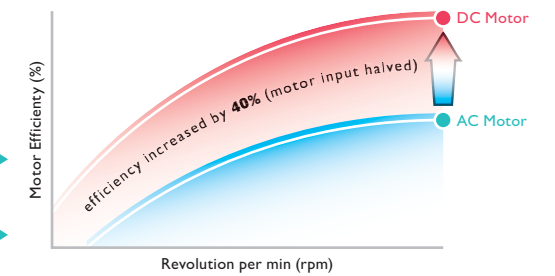

SILENT OPERATION



Low Sound Level / Silent Operation / Silent T-Fan

The trapezoidal blades cut through the air diagonally to minimize air resistance, and its conical blade ensures a high airflow. With a bigger fan diameter, lower noise down to 20dB is produced at low rotation.

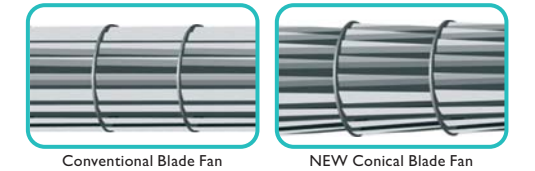

Low Voltage DC Power System

Electromagnetic waves in conventional AC motors are totally eliminated with Hitachi's DC power system, which is absolutely safe and more efficient than conventional type.

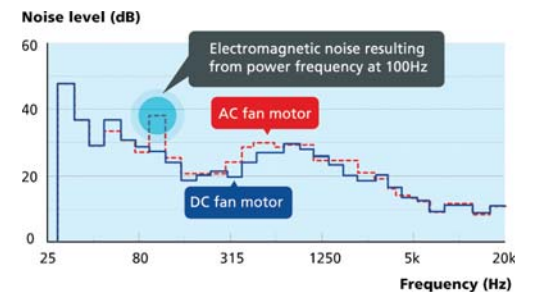

Sleep Function

Sleep function enables the device to turn off automatically after continue working for the designated number of hours set by users. A timer indicated in the remote control will be turned off by the sleep timer and turned on by the on-timer automatically.

Mode	Indication
Sleep timer	→ 1 hour > 2 hours > 3 hours > 7 hours → ← Sleep timer off ←

ANTI-CORROSION TREATMENT



Green Fin

The special anti-corrosion coating on the outdoor heat exchanger improves durability while the green tint harmonizes with the outdoor environment.

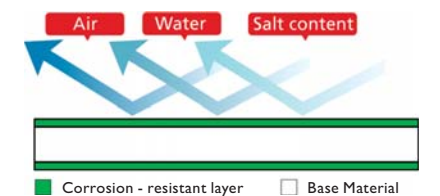

INDOOR UNIT WALL MOUNTED (RAK)

Powerful

A bigger, compact flap delivers air quickly to every corner of the room and the powerful, sweeping airflow eliminates dead zones and improves the cooling and heating effect.

Wall Mounted Type



Silent

The trapezoidal blades cut the air diagonally to minimize air resistance and the conical blade fan ensures a high airflow. With this diagonal air blow, less friction is caused, which reduces noise and improves efficiency. The fan diameter has been increased from the conventional 90mm to 100mm.



Tangential Fan

With diagonal air blow, less friction is caused, which reduces noise and improves efficiency.

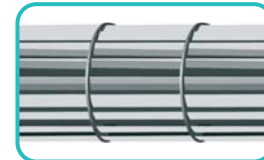

Conventional Blade Fan



NEW Conical Blade Fan

Efficient

The Lambda-shaped heat exchanger's advanced design has a wide suction area and graduation – design grill which both increase the efficiency and performance of the heat exchanger. The wide suction area increases the air intake which enables the units to adjust the room temperature quickly.

Clean

A washable carbon and anti-bacteria air purifying filter ensures that the micro dust, pollen particles and odours that can collect on filters can be easily removed. The filters can be washed and reused up to 20 times.

Air Quality

Either the SPX-CFH5 or SPX-CFH11, washable carbon and anti-bacteria air purifying filters are included in all of Hitachi's room air conditioning products. This ensures that the micro dust, pollen particles and odours that can collect on filters can be easily removed. The filters can be washed and reused up to 20 times.



Reusable after washing

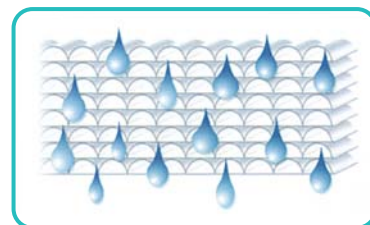

Breathable structure. Micro level dust is absorbed by static electricity

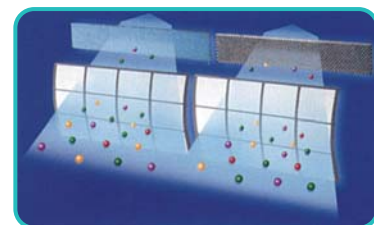

SPX-CH5, SPX-CH11

RAK Technical Description

General Data

MODEL	RAK-18NHAI	RAK-25NHAI	RAK-35NHAI	RAK-50NHAI	RAK-60NHAI	RAK-70NHAI
Power Supply	DC35V	DC35V	DC35V	DC35V	DC35V	DC35V
Sound Pressure Level (Overall Scale)						
Cooling (dBA)	35 / 30 / 25 / 20	38 / 32 / 26 / 20	41 / 35 / 29 / 25	47 / 39 / 31 / 27	47 / 42 / 33 / 28	48 / 42 / 33 / 30
Heating (dBA)	36 / 33 / 27 / 23	39 / 33 / 27 / 23	41 / 35 / 30 / 26	47 / 39 / 31 / 27	47 / 42 / 34 / 33	49 / 42 / 33 / 33
Outer Dimension (Net/Carton)						
Height (mm)	280 / 254	280 / 254	280 / 254	280 / 254	295 / 271	295 / 271
Width (mm)	780 / 826	780 / 826	780 / 826	780 / 826	1030 / 1100	1030 / 1100
Depth (mm)	210 / 325	210 / 325	210 / 325	210 / 325	191 / 368	191 / 368
Weight (kg)	9 / 11	9.5 / 11	9.5 / 11	9.5 / 11	11 / 13	11 / 13
Refrigerant	R410A	R410A	R410A	R410A	R410A	R410A
Flow Control	-	-	-	-	-	-
Indoor Fan						
Air Flow Rate Cooling (ℓ/sec)	121.7 / 111.7 / 96.7	141.7 / 116.7 / 100.0	168.4 / 133.4 / 108.4	225.0 / 166.7 / 113.4	225.0 / 208.4 / 188.4	233.4 / 208.4 / 188.4
Air Flow Rate Heating (ℓ/sec)	133.4 / 116.7 / 96.7	158.4 / 133.4 / 116.7	180.0 / 141.7 / 125.0	225.0 / 166.7 / 113.4	225.0 / 208.4 / 188.4	233.4 / 208.4 / 188.4
Refrigerant Piping						
Liquid Line (mm/in)	6.35 / 1/4	6.35 / 1/4	6.35 / 1/4	6.35 / 1/4	6.35 / 1/4	6.35 / 1/4
Gas Line (mm/in)	9.52 / 3/8	9.52 / 3/8	9.52 / 3/8	12.7 / 1/2	12.7 / 1/2	15.88
Interconnection Wires (pcs)	3	3	3	3	3	3
Auto Restart by Previous Mode	Yes	Yes	Yes	Yes	Yes	Yes
LED Self Diagnosis	Yes	Yes	Yes	Yes	Yes	Yes
Air Purifying Filter Type	SPX-CFH11	SPX-CFH11	SPX-CFH11	SPX-CFH11	SPX-CFH5	SPX-CFH5
Anti-bacterial Tangential Fan	Yes	Yes	Yes	Yes	Yes	Yes
Remote Control Timer (hr)	24	24	24	24	24	24

MULTIZONE combination. For capacity information, please refer to Combination Table

NOTES:

Cooling Operation Conditions
Indoor Air Inlet Temperature: 27°C DB / 19°C WB
Outdoor Air Inlet Temperature: 35°C DB

Piping Length: 7.5m
Piping Lift: 0m

Heating Capacity Conditions
Indoor Air Inlet Temperature: 20°C DB
Outdoor Air Inlet Temperature: 7°C DB / 6°C WB

Sound Pressure Level Measurement Distance:
1m from discharge grille
0.8m beneath the unit's height centre

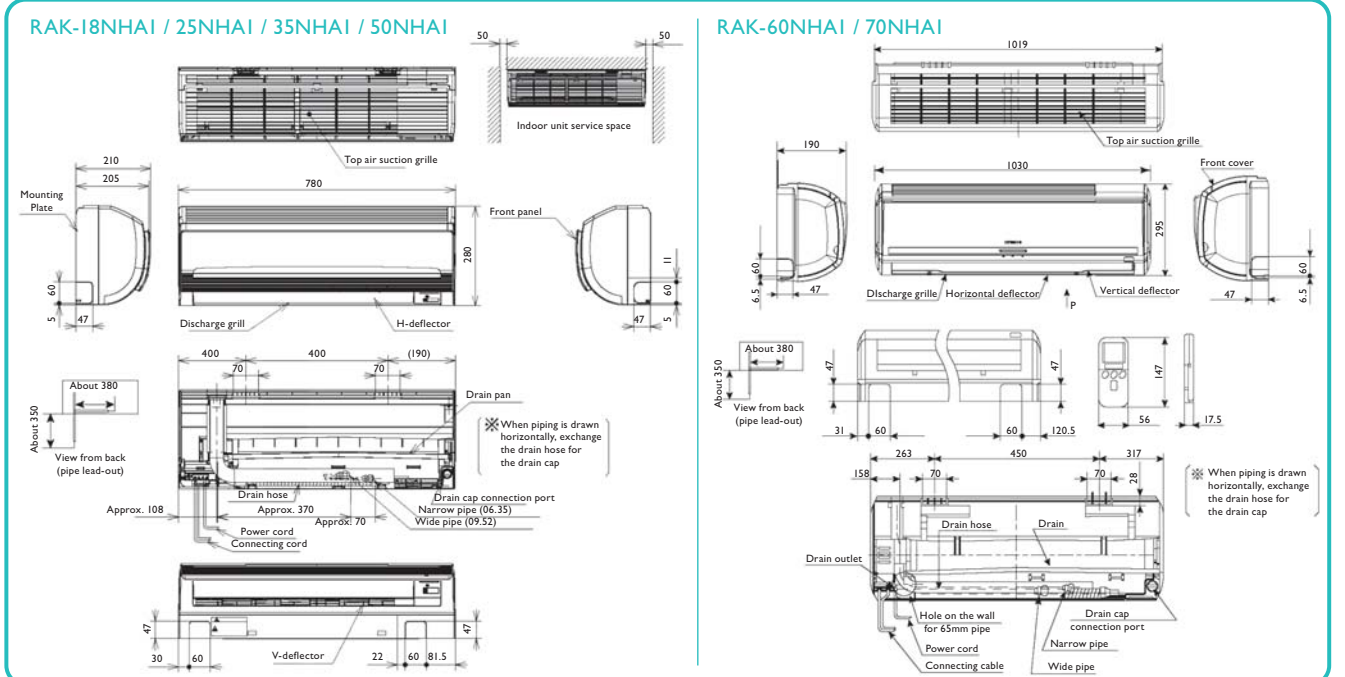

INDOOR UNIT 60CM × 60CM CASSETTE (RAI)

Fits into 60cm × 60cm Ceiling Module

With its compact design, the 60cm × 60cm ceiling unit neatly fits inside a standard ceiling module which minimizes the installation work.

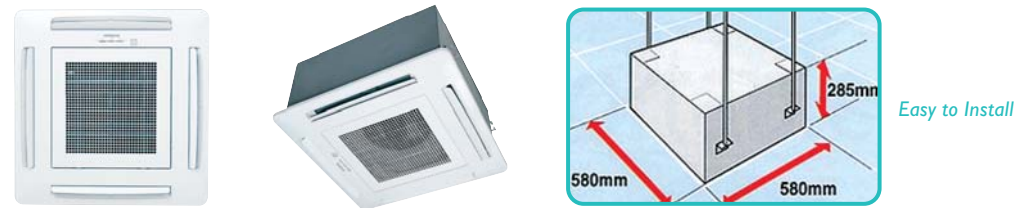

Silent

The noise level is just 25dB (sleep mode) thanks to the 3D-twisted wing design of the compact turbo-fan

4-Way Cassette Type



Flexible Airflow System

The user can select between 2-way, 3-way or 4-way operation of auto swing louvers.



Built-in Drain Pump

The unit is equipped with an internal drain pump to remove accumulated condensation water from the drain pan even while it is operating. A float switch monitors the water level and automatically activates the pump as necessary.



One-Touch Panel

The panel can be swung open up to 90°C with just one push so that the filter can be removed for cleaning.

Solidly Silent Operation and Captivating Design for All Interiors

24% less ventilating resistance with compact unit for silent operation

Super-high-stream turbo fan (three-dimensional twisted wing with large bore and high efficiency) enables greater wind flow efficiency - 20% over conventional machines, patent pending. The underdamping slit mounted near the center of the revolving shaft helps reduce the electromagnetic noise of DC motors caused by the number of magnetic poles and revolution speed of the motor.

DC motor reduces fan motor input

A magnetic surface-mounted rotor, centralized winding system and split core system enables reduction of motor input and thus, improves the motor efficiency.

RAI Technical Description

General Data

MODEL	RAI-25NHA1	RAI-35NHA1	RAI-50NHA1	RAI-ECPM
Power Supply	DC35V	DC35V	DC35V	DC35V
Sound Pressure Level (Overall Scale)				
Cooling (dBA)	35 / 32 / 29 / 25	39 / 34 / 29 / 26	43 / 35 / 32 / 29	-
Heating (dBA)	36 / 33 / 30 / 27	40 / 36 / 32 / 29	44 / 39 / 34 / 31	-
Outer Dimension (Net/Carton)				
Height (mm)	285 / 395	285 / 395	285 / 395	32 / 124
Width (mm)	580 / 760	580 / 760	580 / 760	650 / 710
Depth (mm)	580 / 760	580 / 760	580 / 760	650 / 710
Weight (kg)	20 / 25	20 / 25	20 / 25	4 / 5
Refrigerant	R410A	R410A	R410A	-
Flow Control	-	-	-	-
Indoor Fan				
Air Flow Rate Cooling (ℓ/sec)	141.7 / 116.7 / 96.7	180.0 / 133.4 / 96.7	200.0 / 133.4 / 96.7	-
Air Flow Rate Heating (ℓ/sec)	141.7 / 116.7 / 96.7	180.0 / 133.4 / 96.7	200.0 / 133.4 / 96.7	-
Refrigerant Piping				
Liquid Line (mm/in)	6.35 / 1/4	6.35 / 1/4	6.35 / 1/4	-
Gas Line (mm/in)	9.52 / 3/8	9.52 / 3/8	12.7 / 1/2	-
Interconnection Wires (pcs)	3	3	3	3
Auto Restart by Previous Mode	Yes	Yes	Yes	Yes
LED Self Diagnosis	Yes	Yes	Yes	Yes
Air Purifying Filter Type	-	-	-	(SPX-CFH5)*
Anti-bacterial Tangential Fan	-	-	-	-
Remote Control Timer (hr)	24	24	24	-

MULTIZONE combination. For capacity information, please refer to Combination Table.

NOTES:

Cooling Operation Conditions
Indoor Air Inlet Temperature: 27°C DB / 19°C WB
Outdoor Air Inlet Temperature: 35°C DB

Heating Capacity Conditions
Indoor Air Inlet Temperature: 20°C DB
Outdoor Air Inlet Temperature: 7°C DB / 6°C WB

Piping Length: 7.5m
Piping Lift: 0m

Sound Pressure Level Measurement Distance:
1.4m from beneath the unit

RAI-25NHA1 / 35NHA1 / 50NHA1

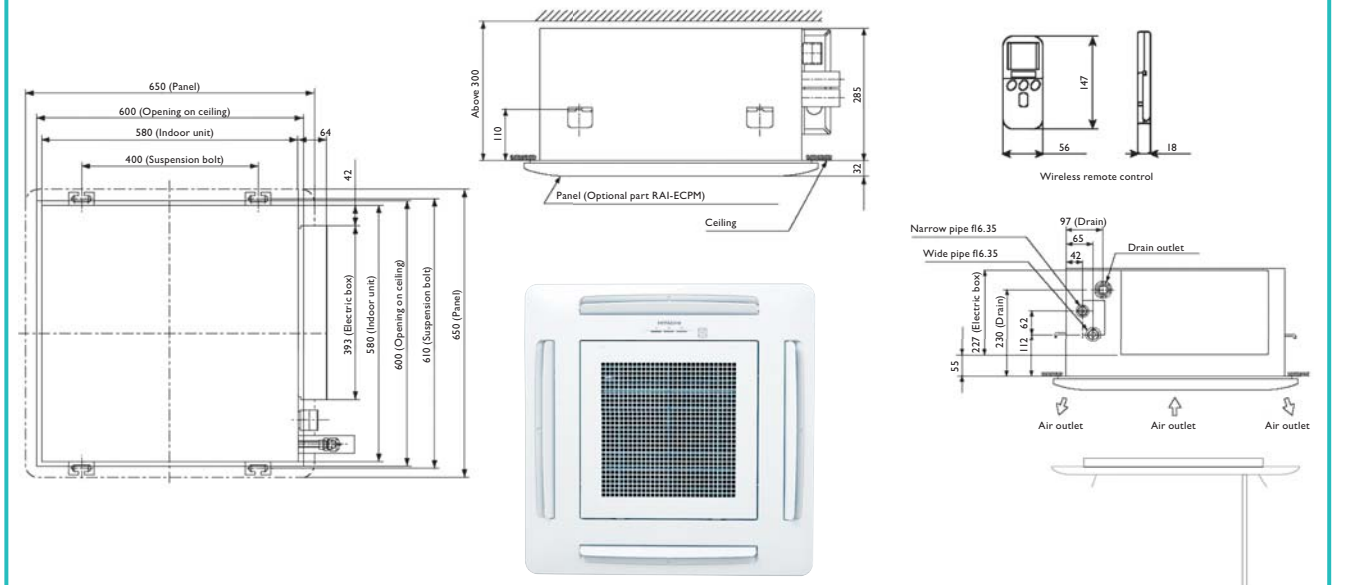

INDOOR UNIT DUCT TYPE (RAD)

Static Pressure & Airflow

The ceiling unit is equipped with a highly efficient, multi-blade centrifugal fan that generates a powerful yet gentle airflow throughout the room. A redesigned aerodynamically tested air panel minimizes operational sound even at high fan speeds.

Duct Type

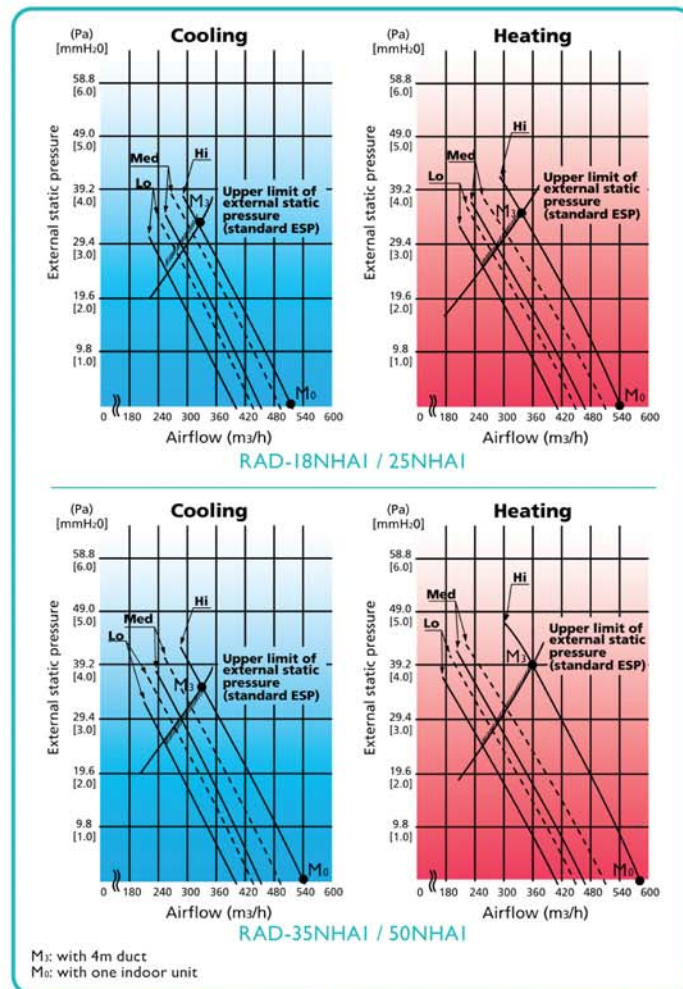

Easy to Install

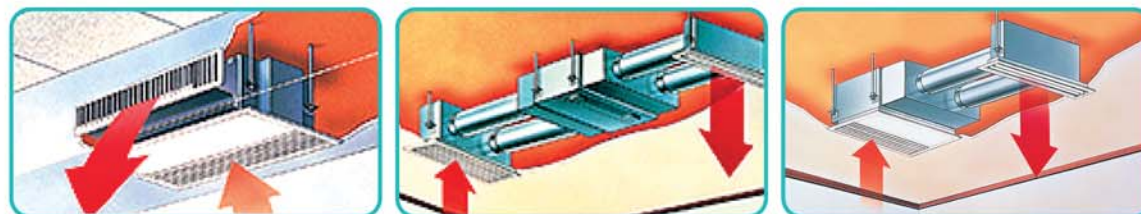

The in-the-ceiling unit enables the air inlet and outlet system to be freely chosen depending on the building structure and room width, thus keeping your room looking beautiful.

Up to 4m ductwork may be installed as the unit comes with a "high pressure" setting, enabling units to overcome the added external pressure. The unit also comes with standard wired remote control and pre filter.

Built-in Drain Pump

The ductable unit is equipped with an internal drain pump to remove accumulated condensation water from the drain pan even while it is operating. A float switch monitors the water level and automatically activates the pump as necessary.



RAD Technical Description

General Data

MODEL	RAD-18NHAI	RAD-25NHAI	RAD-35NHAI	RAD-50NHAI
Power Supply	DC35V	DC35V	DC35V	DC35V
Sound Pressure Level (Overall Scale)				
Cooling (dBA)	40 / 34 / 31 / 29	40 / 34 / 31 / 29	40 / 34 / 31 / 29	44 / 35 / 32 / 29
Heating (dBA)	40 / 36 / 33 / 30	40 / 36 / 33 / 30	40 / 36 / 33 / 30	44 / 39 / 37 / 30
Outer Dimension (Net/Carton)				
Height (mm)	235 / 306	235 / 306	235 / 306	235 / 306
Width (mm)	750 / 806	750 / 806	750 / 806	750 / 806
Depth (mm)	400 / 594	400 / 594	400 / 594	400 / 594
Weight (kg)	19 / 23	19 / 23	19 / 23	19 / 23
Refrigerant	R410A	R410A	R410A	R410A
Flow Control	-	-	-	-
Indoor Fan				
Air Flow Rate Cooling (ℓ/sec)	136.7 / 121.7 / 103.4	136.7 / 121.7 / 103.4	141.7 / 126.7 / 103.4	141.7 / 126.7 / 103.4
Air Flow Rate Heating (ℓ/sec)	153.4 / 125.0 / 103.4	153.4 / 125.0 / 103.4	155.0 / 126.7 / 103.4	155.0 / 126.7 / 103.4
Refrigerant Piping				
Liquid Line (mm/in)	6.35 / 1/4	6.35 / 1/4	6.35 / 1/4	6.35 / 1/4
Gas Line (mm/in)	9.52 / 3/8	9.52 / 3/8	9.52 / 3/8	12.7 / 1/2
Interconnection Wires (pcs)	3	3	3	3
Auto Restart by Previous Mode	Yes	Yes	Yes	Yes
LED Self Diagnosis	Yes	Yes	Yes	Yes
Air Purifying Filter Type	-	-	-	-
Anti-bacterial Tangential Fan	-	-	-	-
Remote Control Timer (hr)	24	24	24	24

MULTIZONE combination. For capacity information, please refer to Combination Table

NOTES:

Cooling Operation Conditions
Indoor Air Inlet Temperature: 27°C DB / 19°C WB
Outdoor Air Inlet Temperature: 35°C DB

Heating Capacity Conditions
Indoor Air Inlet Temperature: 20°C DB
Outdoor Air Inlet Temperature: 7°C DB / 6°C WB

Piping Length: 7.5m
Piping Lift: 0m

Sound Pressure Level Measurement Distance:
1.4m from beneath the unit

RAD-18NHAI / 25NHAI / 35NHAI / 50NHAI

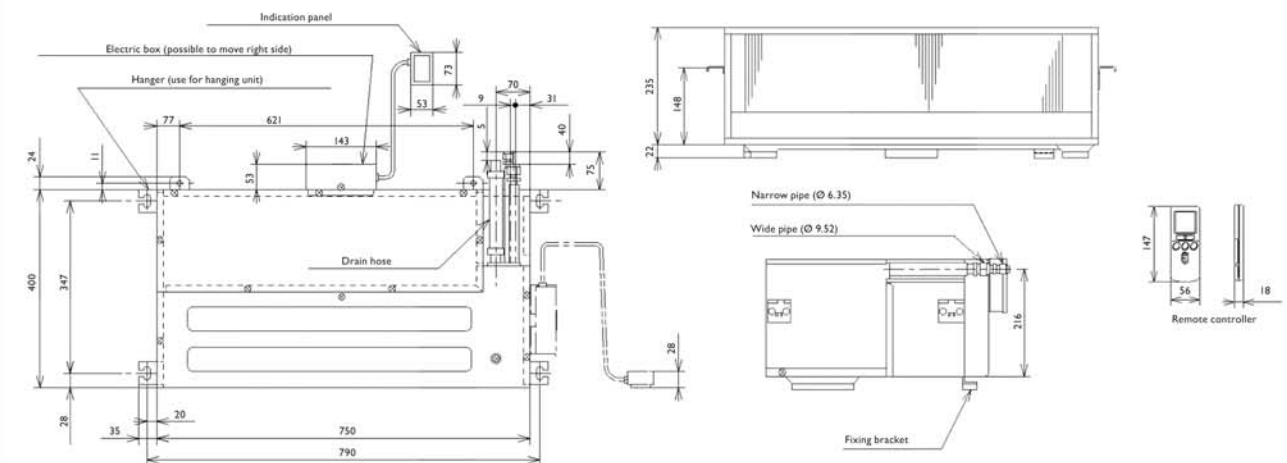

MULTIZONE (RAM)

Technical Description

General Data

	2 ROOMS	2 ROOMS	3 ROOMS
MODEL	RAM-40QHAI	RAM-55QHAI	RAM-65QHAI
Power Supply		AC IPh 220 - 240V 50Hz	
Nominal (min-max) Cooling Capacity (kW)	4.0 (1.0 ~ 4.5)	5.4 (1.5 ~ 5.9)	6.3 (1.5 ~ 6.6)
Nominal (min-max) Heating Capacity (kW)	5.0 (1.1 ~ 5.6)	7.2 (1.5 ~ 7.2)	7.2 (1.5 ~ 7.2)
Sound Pressure Level (Overall Scale)			
Cooling (dBA)	49 / 43	52 / 45	52 / 45
Heating (dBA)	51 / 44	53 / 45	53 / 45
Outer Dimension (Net/Carton)			
Height (mm)	570 / 633	650 / 698	650 / 698
Width (mm)	750 / 905	850 / 1008	850 / 1008
Depth (mm)	280 / 394	298 / 394	298 / 394
Weight (kg)	40 / 44	50 / 55	50 / 55
Cabinet Color (Munsell Code)			
	Beige (5Y 7/2)	Beige (5Y 7/2)	Beige (5Y 7/2)
Refrigerant			
	R410A	R410A	R410A
Flow Control			
	Expansion Valve	Expansion Valve	Expansion Valve
Compressor			
Type	DC Twin Rotary	DC Twin Rotary	DC Twin Rotary
Qty (set)	1	1	1
Condenser Fan			
Type	DC350V	DC350V	DC350V
Air Flow Rate Cooling/Heating (ℓ/sec)	450.0 / 450.0	600.1 / 600.1	600.1 / 600.1
Usable Outdoor Temperature			
Cooling	-10 ~ 43	-10 ~ 43	-10 ~ 43
Heating	-15 ~ 21	-15 ~ 21	-15 ~ 21
Refrigerant Piping			
Liquid Line (mm/in)	6.35 / 1/4 × 2	6.35 / 1/4 × 2	6.35 / 1/4 × 3
Gas Line (mm/in)	9.52 / 3/8 × 2	9.52 / 3/8 × 2	9.52 / 3/8 × 3
Pipe Run			
Max Pipe Length (m)	35	35	45
Max Chargeless Length (m)	35	35	35
Additional Charges (g/m)	-	-	20
Individual Pipe Length (m)	25	25	25
Max Pipe Lift (m)	10	10	10
Starting Current (A)			
	10	10	10
Recommended Fuse Size			
	16	16	16
Interconnection Wires (pcs)			
	3	3	3
LED Self Diagnosis			
	Yes	Yes	Yes

NOTES:

Cooling Operation Conditions
 Indoor Air Inlet Temperature: 27°C DB / 19°C WB
 Outdoor Air Inlet Temperature: 35°C DB

Piping Length: 7.5m
Piping Lift: 0m

Heating Capacity Conditions
 Indoor Air Inlet Temperature: 20°C DB
 Outdoor Air Inlet Temperature: 7°C DB / 6°C WB

Sound Pressure Level Measurement Distance:
 RAK : 1m from from discharge grille / 0.8 beneath the unit's height centre
 RAI / RAD : 1.4m beneath the unit
 RAM : 1m from suction/discharge grille / Approx. 1m from floor level



	4 ROOMS	4 ROOMS	5 ROOMS	6 ROOMS
MODEL	RAM-72QHAI	RAM-80QHA	RAM-90QHAI	RAM-130QHAI
Power Supply		AC IPh 220 - 240V 50Hz		
Nominal (min-max) Cooling Capacity (kW)	7.1 (2.4 ~ 8.8)	8.0 (3.0 ~ 9.2)	9.0 (3.2 ~ 9.9)	12.6 (1.5 ~ 13.2)
Nominal (min-max) Heating Capacity (kW)	8.6 (2.6 ~ 9.5)	11.0 (3.0 ~ 12.4)	11.0 (3.4 ~ 12.1)	14.4 (1.5 ~ 14.4)
Sound Pressure Level (Overall Scale)				
Cooling (dBA)	53 / 46	49 / 43	55 / 46	55 / 48
Heating (dBA)	56 / 48	51 / 43	58 / 52	56 / 48
Outer Dimension (Net/Carton)				
Height (mm)	800 / 848	830 / 880	800 / 867	1450 / 1590
Width (mm)	850 / 1008	850 / 997	950 / 1073	855 / 1070
Depth (mm)	298 / 394	340 / 430	370 / 510	308 / 450
Weight (kg)	55 / 60	79 / 83	71 / 78	113 / 130
Cabinet Color (Munsell Code)				
	Beige (5Y 7/2)	Beige (5Y 7/2)	Natural Grey (1.0Y 8.5/0.5)	Beige (5Y 7/2)
Refrigerant				
	R410A	R410A	R410A	R410A
Flow Control				
	Expansion Valve	Expansion Valve	Expansion Valve	Expansion Valve
Compressor				
Type	DC Twin Rotary	DC Scroll	DC Twin Rotary	DC Twin Rotary
Qty (set)	1	2	1	2
Condenser Fan				
Type	DC350V	DC350V	DC350V	DC350V (2 pcs)
Air Flow Rate Cooling/Heating (ℓ/sec)	750.2 / 750.2	716.8 / 816.8	1083.6 / 1083.6	1200.2 / 1200.2
Usable Outdoor Temperature				
Cooling	-10 ~ 43	10 ~ 43	-10 ~ 43	-10 ~ 43
Heating	-15 ~ 21	-15 ~ 21	-15 ~ 21	-15 ~ 21
Refrigerant Piping				
Liquid Line (mm/in)	6.35 / 1/4 × 4	6.35 / 1/4 × 4	6.35 / 1/4 × 5	6.35 / 1/4 × 6
Gas Line (mm/in)	9.52 / 3/8 × 3	9.52 / 3/8 × 4	9.52 / 3/8 × 3	9.52 / 3/8 × 6
	12.7 / 1/2 × 1		12.7 / 1/2 × 2	
Pipe Run				
Max Pipe Length (m)	60	35 + 35	75	Indoor 1,2,3 : 45 Indoor 4,5,6 : 45
Max Chargeless Length (m)	30	35 + 35	30	35 : 35
Additional Charges (g/m)	20	-	25	20 : 20
Individual Pipe Length (m)	25	25	25	25 : 25
Max Pipe Lift (m)	10	10	10	10 : 10
Starting Current (A)				
	16	14.5	17	20
Recommended Fuse Size				
	30	16	30	30
Interconnection Wires (pcs)				
	3	3	3	3
LED Self Diagnosis				
	Yes	Yes	Yes	Yes

NOTES:

Cooling Operation Conditions
 Indoor Air Inlet Temperature: 27°C DB / 19°C WB
 Outdoor Air Inlet Temperature: 35°C DB

Piping Length: 7.5m
Piping Lift: 0m

Heating Capacity Conditions
 Indoor Air Inlet Temperature: 20°C DB
 Outdoor Air Inlet Temperature: 7°C DB / 6°C WB

Sound Pressure Level Measurement Distance:
 RAK : 1m from from discharge grille / 0.8 beneath the unit's height centre
 RAI / RAD : 1.4m beneath the unit
 RAM : 1m from suction/discharge grille / Approx. 1m from floor level



COMBINATION TABLE MULTIZONE (RAM)

RAM-40QHA1 (2 rooms)

At least two indoor units should be connected

Table for RAM-40QHA1 (2 rooms) showing Cooling Mode and Heating Mode specifications for combinations of 1.8, 2.5, and 3.5 kW indoor units.

RAM-55QHA1 (2 rooms)

Table for RAM-55QHA1 (2 rooms) showing Cooling Mode and Heating Mode specifications for combinations of 1.8, 2.5, 3.5, and 5.0 kW indoor units.

RAM-65QHA1 (3 rooms)

At least two indoor units should be connected

Table for RAM-65QHA1 (3 rooms) showing Cooling Mode and Heating Mode specifications for combinations of 1.8, 2.5, 3.5, and 5.0 kW indoor units.

RAM-72QHA1 (4 rooms)

At least two indoor units should be connected

Table for RAM-72QHA1 (4 rooms) showing Cooling Mode and Heating Mode specifications for combinations of 1.8, 2.5, 3.5, 5.0, 6.0, and 7.1 kW indoor units.

RAM-80QHA (4 rooms)

	Combination of Indoor Units (kW)	Total (kW)	Cooling Mode				Heating Mode						
			Capacity (kW)	Total	Outdoor Unit		Capacity (kW)	Total	Outdoor Unit		COP		
					Total Input (W)	Total Current (A)			Total Input (W)	Total Current (A)			
ONE UNIT	1.8	1.8	1.8 (1.00-2.50)	1.8	560 (360-750)	2.4	3.21	2.50 (1.10-3.20)	2.5	690 (320-970)	2.9	3.62	
	2.5	2.5	2.5 (1.00-2.80)	2.5	780 (360-980)	3.3	3.21	3.90 (1.10-4.70)	3.9	1100 (320-1280)	4.6	3.55	
	3.5	3.5	3.5 (1.00-4.00)	3.5	1160 (360-1280)	4.9	3.02	4.80 (1.10-5.80)	4.8	1380 (320-1750)	5.8	3.48	
	5.0	5.0	5.0 (1.00-5.60)	5.0	1780 (360-2100)	7.5	2.62	6.70 (1.10-7.60)	6.7	2070 (320-2170)	8.7	3.24	
TWO UNITS	1.8+1.8	3.6	1.80+1.80 (1.50-4.10)	3.6	1120 (640-1240)	4.9	3.21	2.50+2.50 (1.50-5.50)	5.0	1380 (600-1520)	5.8	3.62	
	1.8+2.5	4.3	1.80+2.50 (1.50-4.50)	4.3	1320 (640-1450)	5.6	3.26	2.50+3.90 (1.50-7.00)	6.4	1770 (600-1950)	7.4	3.62	
	1.8+3.5	5.3	1.80+3.50 (1.50-5.80)	5.3	1760 (640-1940)	7.4	3.01	2.50+4.80 (1.50-8.40)	7.3	2150 (600-2380)	9.0	3.40	
	1.8+5.0	6.8	1.70+4.90 (1.50-7.20)	6.0	1990 (640-2190)	8.4	3.02	2.20+6.00 (1.50-9.00)	8.2	2850 (600-3150)	12.0	2.88	
	2.5+2.5	5.0	2.50+2.50 (1.50-5.60)	5.0	1560 (640-1720)	6.6	3.21	3.90+3.90 (1.50-8.60)	7.8	2160 (600-2390)	9.1	3.61	
	2.5+3.5	6.0	2.50+3.50 (1.50-5.60)	6.0	1990 (640-2190)	8.4	3.02	3.90+4.80 (1.60-9.60)	8.7	2690 (600-2690)	11.3	2.23	
	2.5+5.0	7.5	2.50+4.50 (1.50-7.60)	7.0	2600 (640-2860)	10.9	2.69	3.00+6.00 (1.50-9.90)	9.0	3200 (600-3520)	13.5	2.81	
	3.5+3.5	7.0	3.50+3.50 (1.50-7.60)	7.0	2600 (640-2860)	10.9	2.69	4.70+7.00 (1.50-10.30)	9.4	3200 (600-3520)	13.5	2.94	
	3.5+5.0	8.5	3.10+4.40 (1.50-8.00)	7.5	2720 (640-2980)	11.4	2.76	4.00+5.60 (1.50-10.60)	9.6	3300 (600-3630)	13.9	2.91	
	5.0+5.0	10.0	4.00+4.00 (1.50-8.20)	8.0	2760 (640-3040)	11.6	2.90	4.80+4.80 (1.60-10.60)	9.6	3300 (600-3630)	13.9	2.91	
	TWO UNITS	1.8+1.8	3.6	1.80+1.80 (1.50-4.00)	3.6	1120 (640-1230)	4.7	3.21	2.25+2.25 (1.50-5.20)	4.5	1280 (600-1480)	5.4	2.52
		1.8+2.5	4.3	1.70+2.30 (1.50-4.50)	4.0	1280 (640-1400)	5.4	3.13	2.20+2.60 (1.50-5.50)	4.8	1360 (600-1600)	5.7	2.53
1.8+3.5		5.3	1.60+3.40 (1.50-5.50)	5.0	1660 (640-1830)	7.0	3.01	2.00+3.80 (1.50-6.40)	5.8	1580 (600-1740)	6.6	3.67	
1.8+5.0		6.8	1.50+4.10 (1.50-6.20)	5.6	1860 (640-2050)	7.8	3.01	1.70+4.50 (1.50-6.80)	6.2	1930 (600-2120)	8.1	3.21	
2.5+2.5		5.0	2.50+2.50 (1.50-5.50)	5.0	1660 (640-1830)	7.0	3.01	2.90+2.90 (1.50-6.40)	5.8	1580 (600-1740)	6.6	3.67	
2.5+3.5		6.0	2.30+3.30 (1.50-6.20)	5.6	1860 (640-2050)	7.8	3.01	2.60+3.60 (1.50-6.80)	6.2	1930 (600-2120)	8.1	3.21	
3.5+3.5		7.0	2.80+2.80 (1.50-6.20)	5.6	1860 (640-2050)	7.8	3.01	3.10+3.10 (1.50-6.80)	6.2	1930 (600-2120)	8.1	3.21	
THREE UNITS		1.8+1.8+1.8	5.4	1.80+1.80+1.80 (3.00-6.00)	5.4	1750 (620-2100)	7.4	3.09	2.50+2.50+2.50 (3.00-8.30)	7.5	1860 (620-2630)	7.8	4.03
	1.8+1.8+2.5	6.1	1.80+1.80+2.50 (3.00-6.70)	6.1	1980 (650-2380)	8.3	3.08	2.50+2.50+3.90 (3.00-9.80)	8.9	2210 (620-2630)	9.3	4.03	
	1.8+1.8+3.5	7.1	1.80+1.80+3.50 (3.00-7.50)	7.1	2300 (650-2760)	9.7	3.09	2.50+2.50+4.80 (3.00-10.80)	9.8	2430 (620-2630)	10.2	4.03	
	1.8+1.8+5.0	8.6	1.70+1.70+4.60 (3.00-8.20)	8.0	2580 (650-3200)	10.9	3.10	2.20+2.20+5.80 (3.00-11.20)	10.2	2530 (620-2630)	10.6	4.03	
	1.8+2.5+2.5	6.8	1.80+2.50+2.50 (2.20-8.00)	6.8	2250 (650-2700)	9.5	3.02	2.50+3.85+3.85 (3.00-11.20)	10.2	2530 (620-2630)	10.6	4.03	
	1.8+2.5+3.5	7.8	1.25+2.40+3.45 (2.20-8.00)	7.8	2510 (620-2960)	10.6	3.11	2.30+3.50+4.40 (3.00-11.20)	10.2	2530 (620-2630)	10.6	4.03	
	1.8+2.5+5.0	9.3	1.50+2.00+4.50 (3.00-8.20)	8.0	2580 (650-3200)	10.9	3.10	2.00+3.00+5.20 (3.00-11.20)	10.2	2530 (620-2630)	10.6	4.03	
	1.8+3.5+3.5	8.8	1.60+3.20+3.20 (3.00-8.20)	8.0	2580 (650-3200)	10.9	3.10	2.00+4.10+4.10 (3.00-11.20)	10.2	2530 (620-2630)	10.6	4.03	
	1.8+3.5+5.0	10.3	1.50+2.50+4.00 (3.00-8.20)	8.0	2580 (650-3200)	10.9	3.10	1.80+3.50+4.90 (3.00-11.20)	10.2	2530 (620-2630)	10.6	4.03	
	1.8+5.0+5.0	11.8	1.20+3.40+3.40 (3.00-8.20)	8.0	2580 (650-3200)	10.9	3.10	1.60+4.30+4.30 (3.00-11.20)	10.2	2530 (620-2630)	10.6	4.03	
	2.5+2.5+2.5	7.5	2.50+2.50+2.50 (3.00-8.20)	7.5	2420 (650-3200)	10.2	3.10	3.40+3.40+3.40 (3.00-11.20)	10.2	2530 (620-2630)	10.6	4.03	
	2.5+2.5+3.5	8.5	2.30+2.30+3.40 (3.00-8.20)	8.0	2580 (650-3200)	10.9	3.10	3.00+3.00+4.20 (3.00-11.20)	10.2	2530 (620-2630)	10.6	4.03	
	2.5+2.5+5.0	10.0	2.00+2.00+4.00 (3.00-8.20)	8.0	2580 (650-3200)	10.9	3.10	2.60+2.60+5.00 (3.00-11.20)	10.2	2530 (620-2630)	10.6	4.03	
	2.5+3.5+3.5	9.5	2.00+3.00+3.00 (3.00-8.20)	8.0	2580 (650-3200)	10.9	3.10	2.60+3.80+3.80 (3.00-11.20)	10.2	2530 (620-2630)	10.6	4.03	
	2.5+3.5+5.0	11.0	1.80+2.60+3.60 (3.00-8.20)	8.0	2580 (650-3200)	10.9	3.10	2.30+3.30+4.60 (3.00-11.20)	10.2	2530 (620-2630)	10.6	4.03	
	3.5+3.5+3.5	10.5	2.66+2.66+2.66 (3.00-8.20)	8.0	2580 (650-3200)	10.9	3.10	3.40+3.40+3.40 (3.00-11.20)	10.2	2530 (620-2630)	10.6	4.03	
3.5+3.5+5.0	12.0	2.40+2.40+3.20 (3.00-8.20)	8.0	2580 (650-3200)	10.9	3.10	3.00+3.00+4.20 (3.00-11.20)	10.2	2530 (620-2630)	10.6	4.03		
FOUR UNITS	1.8+1.8+1.8+1.8	7.2	1.80+1.80+1.80+1.80 (3.00-8.30)	7.2	2280 (650-2750)	9.6	3.16	2.50+2.50+2.50+2.50 (3.00-12.40)	10.0	2560 (620-2630)	10.8	3.91	
	1.8+1.8+1.8+2.5	7.9	1.80+1.80+1.80+2.50 (3.00-9.00)	7.9	2580 (650-3100)	10.9	3.06	2.40+2.40+2.40+3.80 (3.00-12.40)	11.0	2630 (620-2630)	11.1	4.18	
	1.8+1.8+1.8+3.5	8.9	1.60+1.60+1.60+3.20 (3.00-9.20)	8.0	2650 (650-3200)	11.2	3.02	2.30+2.30+2.30+4.10 (3.00-12.40)	11.0	2630 (620-2630)	11.1	4.18	
	1.8+1.8+1.8+5.0	10.4	1.40+1.40+1.40+3.80 (3.00-9.20)	8.0	2650 (650-3200)	11.2	3.02	2.00+2.00+2.00+5.00 (3.00-12.40)	11.0	2630 (620-2630)	11.1	4.18	
	1.8+1.8+2.5+2.5	8.6	1.70+1.70+2.30+2.30 (3.00-9.20)	8.0	2650 (650-3200)	11.2	3.02	2.20+2.20+3.30+3.30 (3.00-12.40)	11.0	2630 (620-2630)	11.1	4.18	
	1.8+1.8+2.5+3.5	9.5	1.50+1.50+2.10+2.90 (3.00-9.20)	8.0	2650 (650-3200)	11.2	3.02	2.00+2.00+3.10+3.90 (3.00-12.40)	11.0	2630 (620-2630)	11.1	4.18	
	1.8+1.8+2.5+5.0	11.1	1.30+1.30+1.80+3.60 (3.00-9.20)	8.0	2650 (650-3200)	11.2	3.02	1.80+1.80+2.70+4.70 (3.00-12.40)	11.0	2630 (620-2630)	11.1	4.18	
	1.8+1.8+3.5+3.5	10.6	1.40+1.40+2.60+2.60 (3.00-9.20)	8.0	2650 (650-3200)	11.2	3.02	1.90+1.90+3.60+3.60 (3.00-12.40)	11.0	2630 (620-2630)	11.1	4.18	
	1.8+2.5+2.5+2.5	9.3	1.40+2.20+2.20+2.20 (3.00-9.20)	8.0	2650 (650-3200)	11.2	3.02	2.00+3.00+3.00+3.00 (3.00-12.40)	11.0	2630 (620-2630)	11.1	4.18	
	1.8+2.5+2.5+3.5	10.3	1.40+2.00+2.00+2.60 (3.00-9.20)	8.0	2650 (650-3200)	11.2	3.02	1.80+2.80+2.80+3.60 (3.00-12.40)	11.0	2630 (620-2630)	11.1	4.18	
	1.8+2.5+2.5+5.0	11.8	1.20+1.70+1.70+3.40 (3.00-9.20)	8.0	2650 (650-3200)	11.2	3.02	1.60+2.60+2.60+4.20 (3.00-12.40)	11.0	2630 (620-2630)	11.1	4.18	
	1.8+2.5+3.5+3.5	11.3	1.20+1.80+2.50+2.50 (3.00-9.20)	8.0	2650 (650-3200)	11.2	3.02	1.70+2.70+3.30+3.30 (3.00-12.40)	11.0	2630 (620-2630)	11.1	4.18	
	2.5+2.5+2.5+2.5	10.0	2.00+2.00+2.00+2.00 (3.00-9.20)	8.0	2650 (650-3200)	11.2	3.02	2.75+2.75+2.75+2.75 (3.00-12.40)	11.0	2630 (620-2630)	11.1	4.18	
	2.5+2.5+2.5+3.5	11.0	1.85+1.85+1.85+2.45 (3.00-9.20)	8.0	2650 (650-3200)	11.2	3.02	2.50+2.50+2.50+3.50 (3.00-12.40)	11.0	2630 (620-2630)	11.1	4.18	
	2.5+2.5+3.5+3.5	12.0	1.70+1.70+2.30+2.30 (3.00-9.20)	8.0	2650 (650-3200)	11.2	3.02	2.30+2.30+2.30+2.30 (3.00-12.40)	11.0	2630 (620-2630)	11.1	4.18	

○ Two Units each unit is connected to each compressor ● Two Units two units are connected to one compressor

RAM-90QHA1 (5 rooms)

	Combination of Indoor Units (kW)	Total (kW)	Cooling Mode				Heating Mode					
			Capacity (kW)	Total	Outdoor Unit		Capacity (kW)	Total	Outdoor Unit		COP	
					Total Input (W)	Total Current (A)			Total Input (W)	Total Current (A)		
ONE UNIT	1.8	1.80	1.80 (1.70-2.00)	1.80	500 (320-610)	2.1	3.60	2.50 (2.00-3.0)	2.50	780 (360-920)	3.3	3.21
	2.5	2.50	2.50 (1.70-2.80)	2.50	700 (320-860)	2.9	3.57	3.40 (2.00-4.0)	3.40	1140 (360-1340)	4.8	2.98
	3.5	3.50	3.50 (1.70-3.90)	3.50	1040 (320-1270)	4.4	3.37	4.30 (2.00-5.20)	4.30	1420 (360-1720)	6.0	3.03
	5.0	5.00	5.00 (1.70-5.50)	5.00	1540 (320-1860)	6.5	3.25	6.50 (2.00-7.30)	6.50	2300 (360-2580)	9.7	2.83
	6.0	6.00	6.00 (1.70-6.40)	6.00	1880 (320-2270)	7.9	3.19	7.30 (2.00-8.20)	7.30	2630 (360-2950)	11.1	2.78
TWO UNITS	1.8+1.8	3.60	1.8+1.8 (2.40-4.00)	3.60	710 (450-860)	3.0	5.07	2.5+2.5 (2.70-6.90)	5.00	1240 (480-1710)	5.2	4.03
	1.8+2.5	4.30	1.8+2.5 (2.00-4.70)	4.30	1000 (450-1190)	4.2	4.30	2.5+3.4 (2.7-7.7)	5.90	1530 (480-1990)	6.4	3.86
	1.8+3.5	5.30	1.8+3.5 (2.40-5.80)	5.30	1590 (450-1900							

continue from previous page

RAM-90QHAI (5 rooms)

Combination of Indoor Units (kW)	Cooling Mode					Heating Mode				
	Capacity (kW)	Total	Outdoor Unit		EER	Capacity (kW)	Total	Outdoor Unit		COP
			Total Input (W)	Total Current (A)				Total Input (W)	Total Current (A)	
2.5+3.5+5.0	2.05+2.85+4.10 (2.70-9.90)	9.00	2770 (S10-3350)	11.7	3.25	2.49+3.15+4.76 (2.9-11.6)	10.40	2990 (S20-3330)	12.6	3.48
2.5+3.5+6.0	1.88+2.62+4.50 (2.70-9.90)	9.00	2780 (S10-3360)	11.7	3.24	2.38+3.01+5.11 (2.9-11.7)	10.50	2990 (S20-3320)	12.6	3.51
2.5+3.5+7.1	1.72+2.40+4.88 (2.70-9.90)	9.00	2780 (S10-3360)	11.7	3.24	2.20+2.79+5.51 (2.9-11.7)	10.50	2990 (S20-3320)	12.6	3.51
2.5+5.0+5.0	1.8+3.6+3.6 (2.70-9.90)	9.00	2780 (S10-3360)	11.7	3.24	2.18+4.16+4.16 (2.9-11.7)	10.50	2990 (S20-3320)	12.6	3.51
2.5+5.0+6.0	1.67+3.33+4.00 (2.70-9.90)	9.00	2780 (S10-3360)	11.7	3.24	2.08+3.97+4.45 (2.9-11.7)	10.50	2990 (S20-3320)	12.6	3.51
2.5+5.0+7.1	1.54+3.08+4.38 (2.70-9.90)	9.00	2850 (S10-3450)	12.0	3.16	2.03+3.89+5.08 (2.9-12.1)	11.00	2890 (S20-3180)	12.2	3.81
2.5+6.0+6.0	1.56+3.72+3.72 (2.70-9.90)	9.00	2770 (S10-3350)	11.7	3.25	2.08+4.46+4.46 (2.9-12.1)	11.00	2890 (S20-3180)	12.2	3.81
3.5+3.5+3.5	3.00+3.00+3.00 (2.70-9.90)	9.00	2740 (S10-3320)	11.5	3.28	3.47+3.47+3.47 (2.9-11.6)	10.40	2990 (S20-3330)	12.6	3.48
3.5+3.5+5.0	2.65+2.65+3.70 (2.70-9.90)	9.00	2780 (S10-3360)	11.7	3.24	2.99+2.99+4.52 (2.9-11.7)	10.50	2990 (S20-3320)	12.6	3.51
3.5+3.5+6.0	2.40+2.40+4.20 (2.70-9.90)	9.00	2780 (S10-3360)	11.7	3.24	2.84+2.84+4.82 (2.9-11.7)	10.50	2990 (S20-3320)	12.6	3.51
3.5+3.5+7.1	2.23+2.23+4.54 (2.70-9.90)	9.00	2850 (S10-3450)	12.0	3.16	2.77+2.77+5.46 (2.9-12.1)	11.00	2890 (S20-3180)	12.2	3.81
3.5+5.0+5.0	2.3+3.5+3.5 (2.70-9.90)	9.00	2780 (S10-3360)	11.7	3.24	2.60+3.95+3.95 (2.9-11.7)	10.50	2990 (S20-3320)	12.6	3.51
3.5+5.0+6.0	2.18+3.10+3.72 (2.70-9.90)	9.00	2850 (S10-3450)	12.0	3.16	2.61+3.95+4.44 (2.9-12.1)	11.00	2890 (S20-3180)	12.2	3.81
3.5+6.0+6.0	2.04+3.48+3.48 (2.70-9.90)	9.00	2850 (S10-3450)	12.0	3.16	2.50+4.25+4.25 (2.9-12.1)	11.00	2890 (S20-3180)	12.2	3.81
5.0+5.0+5.0	3.00+3.00+3.00 (2.70-9.90)	9.00	2850 (S10-3450)	12.0	3.16	3.67+3.67+3.67 (2.9-12.1)	11.00	2890 (S20-3180)	12.2	3.81
1.8+1.8+1.8+1.8	1.80+1.80+1.80+1.80 (2.90-9.90)	7.20	1800 (S50-2310)	7.6	4.00	2.44+2.44+2.44 (3.0-10.9)	9.60	2400 (S40-2720)	10.1	4.00
1.8+1.8+1.8+2.5	1.80+1.80+1.80+2.50 (2.90-9.90)	7.90	2090 (S50-2690)	8.8	3.78	2.25+2.25+2.25+3.05 (3.0-11.1)	9.80	2700 (S40-3050)	11.4	3.63
1.8+1.8+1.8+3.5	1.80+1.80+1.80+3.50 (2.90-9.90)	8.90	2530 (S50-3260)	10.6	3.52	2.16+2.16+2.16+3.72 (3.0-11.4)	10.20	2700 (S40-3020)	11.4	3.78
1.8+1.8+1.8+5.0	1.55+1.55+1.55+4.35 (2.90-9.90)	9.00	2530 (S50-3260)	10.6	3.56	1.82+1.82+1.82+4.74 (3.0-11.4)	10.20	2700 (S40-3020)	11.4	3.78
1.8+1.8+1.8+6.0	1.40+1.40+1.40+4.80 (2.90-9.90)	9.00	2530 (S50-3260)	10.6	3.56	1.72+1.72+1.72+5.04 (3.0-11.4)	10.20	2700 (S40-3020)	11.4	3.78
1.8+1.8+1.8+7.1	1.30+1.30+1.30+5.10 (2.90-9.90)	9.00	2530 (S50-3260)	10.6	3.56	1.59+1.59+1.59+5.43 (3.0-11.4)	10.20	2700 (S40-3020)	11.4	3.78
1.8+1.8+2.5+2.5	1.80+1.80+2.50+2.50 (2.90-9.90)	8.60	2350 (S50-3040)	9.9	3.66	2.12+2.12+2.88+2.88 (3.0-11.2)	10.00	2700 (S40-3030)	11.4	3.70
1.8+1.8+2.5+3.5	1.69+1.69+2.34+2.38 (2.90-9.90)	9.00	2530 (S50-3260)	10.6	3.56	2.01+2.01+2.73+3.45 (3.0-11.4)	10.20	2700 (S40-3020)	11.4	3.78
1.8+1.8+2.5+5.0	1.45+1.45+2.00+4.10 (2.90-9.90)	9.00	2530 (S50-3260)	10.6	3.56	1.71+1.71+2.33+4.45 (3.0-11.4)	10.20	2700 (S40-3020)	11.4	3.78
1.8+1.8+2.5+6.0	1.35+1.35+1.85+4.45 (2.90-9.90)	9.00	2530 (S50-3260)	10.6	3.56	1.62+1.62+2.21+4.75 (3.0-11.4)	10.20	2700 (S40-3020)	11.4	3.78
1.8+1.8+2.5+7.1	1.22+1.22+1.70+4.84 (2.90-9.90)	9.00	2530 (S50-3260)	10.6	3.56	1.54+1.54+2.09+5.23 (3.0-11.6)	10.40	2700 (S40-3010)	11.4	3.85
1.8+1.8+3.5+3.5	1.52+1.52+1.52+2.97 (2.90-9.90)	9.00	2530 (S50-3260)	10.6	3.56	1.88+1.88+3.22+3.22 (3.0-11.4)	10.20	2700 (S40-3020)	11.4	3.78
1.8+1.8+3.5+5.0	1.35+1.35+2.6+3.7 (2.90-9.90)	9.00	2530 (S50-3260)	10.6	3.56	1.61+1.61+2.78+4.2 (3.0-11.4)	10.20	2700 (S40-3020)	11.4	3.78
1.8+1.8+3.5+6.0	1.25+1.25+2.4+4.1 (2.90-9.90)	9.00	2530 (S50-3260)	10.6	3.56	1.57+1.57+2.69+4.57 (3.0-11.6)	10.40	2700 (S40-3010)	11.4	3.85
1.8+1.8+3.5+7.1	1.14+1.14+2.22+4.50 (2.90-9.90)	9.00	2530 (S50-3260)	10.6	3.56	1.54+1.54+2.66+5.26 (3.0-12.1)	11.00	2630 (S40-2890)	11.1	4.18
1.8+1.8+5.0+5.0	1.20+1.20+3.30+3.30 (2.90-9.90)	9.00	2510 (S50-3230)	10.6	3.59	1.44+1.44+3.76+3.76 (3.0-11.6)	10.40	2700 (S40-3010)	11.4	3.85
1.8+1.8+5.0+6.0	1.10+1.10+3.10+3.70 (2.90-9.90)	9.00	2510 (S50-3230)	10.6	3.59	1.46+1.46+3.80+4.28 (3.0-12.1)	11.00	2630 (S40-2890)	11.1	4.18
1.8+2.5+2.5+2.5	1.80+2.40+2.40+2.40 (2.90-9.90)	9.00	2530 (S50-3260)	10.6	3.56	2.01+2.73+2.73+2.73 (3.0-11.4)	10.20	2700 (S40-3020)	11.4	3.78
1.8+2.5+2.5+3.5	1.60+2.20+2.20+3.00 (2.90-9.90)	9.00	2530 (S50-3260)	10.6	3.56	1.88+2.55+2.55+3.22 (3.0-11.4)	10.20	2700 (S40-3020)	11.4	3.78
1.8+2.5+2.5+5.0	1.40+1.90+1.90+3.80 (2.90-9.90)	9.00	2530 (S50-3260)	10.6	3.56	1.61+2.19+2.19+4.21 (3.0-11.4)	10.20	2700 (S40-3020)	11.4	3.78
1.8+2.5+2.5+6.0	1.30+1.75+1.75+4.20 (2.90-9.90)	9.00	2530 (S50-3260)	10.6	3.56	1.54+2.09+2.09+4.48 (3.0-11.4)	10.20	2700 (S40-3020)	11.4	3.78
1.8+2.5+2.5+7.1	1.16+1.62+1.62+4.60 (2.90-9.90)	9.00	2540 (S50-3270)	10.7	3.54	1.54+2.10+2.10+5.26 (3.0-12.1)	11.00	2800 (S40-3080)	11.8	3.93
1.8+2.5+3.5+3.5	1.40+2.00+2.80+2.80 (2.90-9.90)	9.00	2530 (S50-3260)	10.6	3.56	1.75+2.39+3.03+3.03 (3.0-11.4)	10.20	2700 (S40-3020)	11.4	3.78
1.8+2.5+3.5+5.0	1.30+1.75+2.4+3.50 (2.90-9.90)	9.00	2530 (S50-3260)	10.6	3.56	1.53+2.08+2.63+3.96 (3.0-11.4)	10.20	2700 (S40-3020)	11.4	3.78
1.8+2.5+3.5+6.0	1.20+1.60+2.30+3.90 (2.90-9.90)	9.00	2530 (S50-3260)	10.6	3.56	1.57+2.14+2.70+4.59 (3.0-12.1)	11.00	2800 (S40-3080)	11.8	3.93
1.8+2.5+3.5+7.1	1.09+1.51+2.11+4.29 (2.90-9.90)	9.00	2530 (S50-3260)	10.6	3.56	1.47+2.00+2.53+5.00 (3.0-12.1)	11.00	2630 (S40-2890)	11.1	4.18
1.8+2.5+5.0+5.0	1.15+1.55+3.15+3.15 (2.90-9.90)	9.00	2510 (S50-3230)	10.6	3.59	1.46+1.98+3.78+3.78 (3.0-12.1)	11.00	2630 (S40-2890)	11.1	4.18
1.8+2.5+5.0+6.0	1.10+1.50+2.90+3.50 (2.90-9.90)	9.00	2510 (S50-3230)	10.6	3.59	1.40+1.90+3.63+4.07 (3.0-12.1)	11.00	2630 (S40-2890)	11.1	4.18
1.8+3.5+3.5+3.5	1.35+2.55+2.5+2.55 (2.90-9.90)	9.00	2530 (S50-3260)	10.6	3.56	1.65+2.85+2.85+2.85 (3.0-11.4)	10.20	2700 (S40-3020)	11.4	3.78
1.8+3.5+3.5+5.0	1.15+2.30+2.30+3.25 (2.90-9.90)	9.00	2530 (S50-3260)	10.6	3.56	1.56+2.69+2.69+4.06 (3.0-12.1)	11.00	2800 (S40-3080)	11.8	3.93
1.8+3.5+3.5+6.0	1.10+2.10+2.10+3.70 (2.90-9.90)	9.00	2530 (S50-3260)	10.6	3.56	1.49+2.57+2.57+4.37 (3.0-12.1)	11.00	2630 (S40-2890)	11.1	4.18
1.8+3.5+5.0+5.0	1.05+2.05+2.95+2.95 (2.90-9.90)	9.00	2510 (S50-3230)	10.6	3.59	1.39+2.39+3.61+3.61 (3.0-12.1)	11.00	2630 (S40-2890)	11.1	4.18
2.5+2.5+2.5+2.5	2.25+2.25+2.25+2.25 (2.90-9.90)	9.00	2530 (S50-3260)	10.6	3.56	2.55+2.55+2.55+2.55 (3.0-11.4)	10.20	2700 (S40-3020)	11.4	3.78
2.5+2.5+2.5+3.5	2.05+2.05+2.05+2.85 (2.90-9.90)	9.00	2530 (S50-3260)	10.6	3.56	2.39+2.39+2.39+3.03 (3.0-11.4)	10.20	2700 (S40-3020)	11.4	3.78
2.5+2.5+2.5+5.0	1.8+1.8+3.6 (2.90-9.90)	9.00	2530 (S50-3260)	10.6	3.56	2.12+2.12+4.04 (3.0-11.6)	10.40	2700 (S40-3010)	11.4	3.85
2.5+2.5+2.5+6.0	1.67+1.67+4.67+4.00 (2.90-9.90)	9.00	2530 (S50-3260)	10.6	3.56	2.02+2.02+4.34 (3.0-11.6)	10.40	2700 (S40-3010)	11.4	3.85
2.5+2.5+2.5+7.1	1.54+1.54+4.54+3.8 (2.90-9.90)	9.00	2530 (S50-3260)	10.6	3.56	2.00+2.00+5.00 (3.0-12.1)	11.00	2630 (S40-2890)	11.1	4.18
2.5+2.5+3.5+3.5	1.88+1.88+2.62+2.62 (2.90-9.90)	9.00	2530 (S50-3260)	10.6	3.56	2.25+2.25+2.85+2.85 (3.0-11.4)	10.20	2700 (S40-3020)	11.4	3.78
2.5+2.5+3.5+5.0	1.67+1.67+3.33+3.33 (2.90-9.90)	9.00	2530 (S50-3260)	10.6	3.56	2.01+2.01+4.54+3.84 (3.0-11.6)	10.40	2700 (S40-3010)	11.4	3.85

continue next page

continue from previous page

Combination of Indoor Units (kW)	Cooling Mode					Heating Mode				
	Capacity (kW)	Total	Outdoor Unit		EER	Capacity (kW)	Total	Outdoor Unit		COP
			Total Input (W)	Total Current (A)				Total Input (W)	Total Current (A)	
2.5+2.5+3.5+6.0	1.55+1.55+2.0+3.70 (2.90-9.90)	9.00	2530 (S50-3260)	10.6	3.56	2.03+2.03+2.57+4.37 (3.0-12.1)	11.00	2630 (S40-2890)	11.1	4.18
2.5+2.5+5.0+5.0	1.50+1.50+3.00+3.00 (2.90-9.90)	9.00	2510 (S50-3230)	10.6	3.59	1.89+1.89+3.61+3.61 (3.0-12.1)	11.00	2630 (S40-2890)	11.1	4.18
2.5+3.5+3.5+3.5	1.74+2.42+2.42+2.42 (2.90-9.90)	9.00	2530 (S50-3260)	10.6	3.56	2.18+2.74+2.74+2.74 (3.0-11.6)	10.40	2700 (S40-3010)	11.4	3.85
2.5+3.5+3.5+5.0	1.56+2.17+2.17+3.10 (2.90-9.90)	9.00	2530 (S50-3260)	10.6	3.56	2.02+2.56+2.56+3.86 (3.0-12.1)	11.00	2630 (S40-2890)	11.1	4.18
2.5+3.5+3.5+6.0	1.46+2.03+2.03+3.48 (2.90-9.90)	9.00	2530 (S50-3260)	10.6	3.56	1.94+2.45+2.45+4.16 (3.0-12.1)	11.00	2630 (S40-2890)	11.1	4.18
3.5+3.5+3.5+3.5	2.25+2.25+2.25+2.25 (2.90-9.90)	9.00	2530 (S50-3260)	10.6	3.56	2.75+2.75+2.75+2.75 (3.0-12.1)	11.00	2630 (S40-2890)	11.1	4.18
3.5+3.5+3.5+5.0	2.03+2.03+2.03+2.91 (2.90-9.90)	9.00	2530 (S50-3260)	10.6	3.56	2.44+2.44+2.44+3.68 (3.0-12.1)	11.00	2630 (S40-2890)	11.1	4.18
1.8+1.8+1.8+1.8+1.8	1.8+1.8+1.8+1.8+1.8 (3.20-9.90)	9.00	2360 (S60-3040)	9.9	3.81	2.2+2.2+2.2+2.2+2.2 (3.40-12.10)	11.00	2460 (S60-2710)	10.4	4.47
1.8+1.8+1.8+1.8+2.5	1.67+1.67+1.67+1.67+2.32 (3.20-9.90)	9.00	2360 (S60-3040)	9.9	3.81	2.05+2.05+2.05+2.05+2.8 (3.40-12.10)	11.00			